
MSP430™ System-Level ESD Considerations

MSP430 Applications

ABSTRACT

System-Level ESD has become increasingly demanding with silicon technology scaling towards lower voltages and the need for designing cost-effective and ultra-low power components. This application report addresses three different ESD topics to help board designers and OEMs understand and design robust system-level designs:

1. Component-level ESD testing and system-level ESD testing, their differences, and why component-level ESD rating does not ensure system-level robustness.
2. General design guidelines for system-level ESD protection at different levels including enclosures, cables, PCB layout, and on-board ESD protection devices.
3. Introduction to System Efficient ESD Design (SEED, which is a co-design methodology of on-board and on-chip ESD protection to achieve system-level ESD robustness) with example simulations and test results.

Two real-world system-level ESD protection design examples and their results are also discussed.

Contents

1	Introduction to ESD	3
2	General System-Level ESD Design Guidelines	9
3	System Efficient ESD Design (SEED)	22
4	SEED-Based IEC Protection Design and Verification – Real World Example 1	26
5	System-Level ESD Protection – Real World Example 2	32
6	Summary	33
7	References	34
Appendix A	Modeling Using TLP Parameters	35

List of Figures

1	Human Body Model (Similar to JEDEC JS-001 Specification).....	4
2	Charged Device Model (Similar to the JEDEC JESD22-C101 Specification).....	5
3	ESD Test Bench for Powered Condition From IEC 61000-4-2 [1]	6
4	Comparison of Standard HBM, CDM, and IEC Discharge Pulses	8
5	Enclosure Scenarios	10
6	Shielding LEDs	11
7	Enclosure Opening Considerations	12
8	Enclosure Cable Considerations	12
9	Avoid Right-Angle Traces	13
10	Decoupling Basics.....	13
11	Example Crystal Layout	14
12	Example Layout With Solid Ground Plane	15
13	Grounding Considerations For 2-Layer Board With No Dedicated Ground Plane.....	15
14	Return Currents and Resulting Loop Area	16
15	Example 2-Layer PCB Layout Showing Large Current Loop.....	17
16	Example 2-Layer PCB Layout Showing More Continuous Ground Plane And Reduced Current Loop	18
17	System-Level ESD Protection Using Series Resistors	20
18	Two-Stage System-Level ESD Protection [7].....	23
19	IEC ESD Protection Design Schematic.....	25
20	SPICE Simulations	26
21	I-V Characteristics for a Bidirectional ESD Protection Diode	27
22	SEED Method Simulation Schematic	28
23	SEED Schematic and Simulation Results.....	30
24	MSP430-Based Test Board Layout	31
25	MSP430-Based Real-Time Clock Test Boards.....	32
26	Modeling TVS Device Using TLP Parameters.....	35
27	Modeling IC Interface Pin Using TLP Parameters	36

List of Tables

1	Comparison of IC-Level HBM and System-Level ESD Tests [2]	3
2	IEC 61000-4-2 Test Specifications [1].....	7
3	System-Level ESD Performance - Real World Example 2 Results.....	32

1 Introduction to ESD

Static charge is an unbalanced electrical charge at rest. When two non-conductive materials are rubbed together or separated, there is gain of electrons on the surface of one material and loss on the other; this results in an unbalanced electrical conditions known as static charge. The voltage to which an object can be charged depends on the capacitance, following the law $Q = CV$. The human body can be charged to several kV. When this static charge moves from one surface to another, it is called ESD (Electrostatic Discharge). ESD is a single-event rapid transfer of electrostatic charge between two objects that are at different potentials. It can occur only when the voltage differential between the two objects is sufficiently high to break down the dielectric strength of the medium separating them. The rapid movement of the electrostatic charge generates current that damages or destroys gate oxide, metallization, and junctions within an integrated circuit (IC).

ESD can occur in any one of the four ways:

- Charged body touching an IC
- Charged IC touching a grounded surface or object
- Charged metallic tool touching an IC
- An electrostatic field inducing a voltage across a dielectric sufficient enough to break it down.

The coupling mechanisms in each of these cases are inductive, resistive, or capacitive. Creating an ESD-safe design is focused on minimizing ESD coupling by a combination of factors. To design an ESD robust product, it is important to understand that the ESD protection required at component or IC level and at system level are different.

Typically, silicon vendors design, test, and qualify their ICs according to industry standards to ensure no physical damage occurs during IC production or during assembly onto PCBs. The Original Equipment Manufacturer (OEM) should design ESD protection at a system or board level and test according to the IEC 61000-4-2 [1] or ISO 10605 [6] system-level ESD standard. [Table 1](#) summarizes key differences between IC- or component-level standard HBM testing and system-level testing as required by IEC 61000-4-2 [1] and ISO 10605 [6] standards.

Table 1. Comparison of IC-Level HBM and System-Level ESD Tests [2]

Parameter	IC-Level HBM Test (ANSI/ESDA/JEDEC JS-001) [3]	System-Level ESD Test (IEC 61000-4-2 [1], ISO 10605 [6])
Stressed Pin Group	Multitude of pin combinations	Few special pins
Device Power	Non-powered	Powered and non-powered
Test Methodology	Standardized	Application specific using various discharge models
Failure Signature	Leakage or physical device damage	Functional or application failure or physical device damage
Testing and Qualification Owned by	Silicon vendor or component manufacturer	System board designers or OEMs
Test Setup	Commercial tester and sockets	Application-specific board
Typical Qualification Goal	1 kV to 2 kV HBM	8 kV to 15 kV
Corresponding Peak Current	0.65 A to 1.3 A	>20 A
ESD Environment	Assembly and production processes	End-user application, consumer product

The component-level ESD and the system-level ESD test requirements are different as they address different ESD environments. Also, the ESD current waveforms associated with the two tests differ significantly in terms of peak current, duration, and total power. Therefore, to design an ESD robust system, it is important for the system board designers and OEMs to understand that system-level ESD protection requirements are much different from IC-level ESD protection capabilities..

1.1 Component-Level ESD Rating

The ESD protection design for an IC package is known to be critical for safe production and handling. It is commonly understood and accepted that this protection design is expected to meet or exceed the required ESD specification when these ICs are handled in an ESD-safe area, also known as ESD Protected Area (EPA) [1]. The ESD protection strategy for ICs involves discharging of the ESD events that might occur on any pin of the package that is exposed to its environment. The component-level ESD protection should consider the two basic ESD models defined for ICs: Human Body Model (HBM) and Charged Device Model (CDM).

The ESD protection circuitry within MSP430™ ICs is designed based on device technology, IC pin functionalities for different applications, power pins, and so on. The protection elements are first characterized and analyzed for effectiveness using test chips. Simulations and automated checks are used, where appropriate, to ensure effectiveness of the protection circuitry and check for its compatibility with the pin it is designed to protect.

Typical MSP430 devices are tested and qualified to the following industry-standard ESD ratings.

1.1.1 Human Body Model (HBM)

The HBM simulates the ESD event in which a human body discharges the accumulated electrostatic charge by touching an IC that is at a different potential. In a simple approximation, it is modeled by a charged 100-pF capacitor and a 1.5-kΩ discharging resistor, similar to the JEDEC JS-001 specification [3] (see [Figure 1](#)).

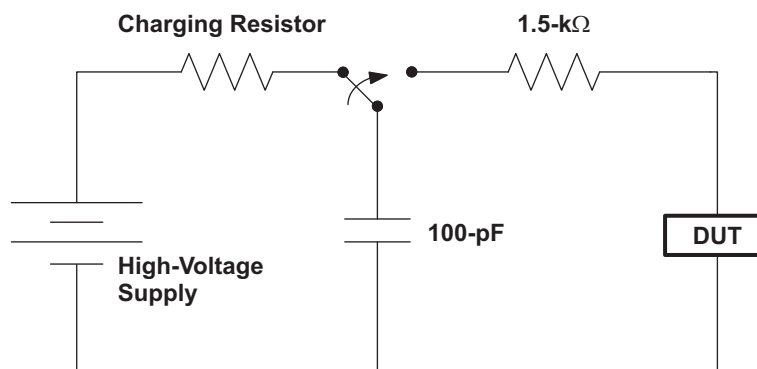


Figure 1. Human Body Model (Similar to JEDEC JS-001 Specification)

1.1.2 Charged Device Model (CDM)

The CDM simulates charging and discharging events that occur in production equipment and processes. It simulates the ESD event in which a device acquires charge through some frictional processes or electrostatic induction process and abruptly touches a grounded object or surface. There is a potential for CDM ESD events to occur when there is a metal-to-metal contact in manufacturing. The test requirements are similar to the JEDEC JESD22-C101 specification [4] (see [Figure 2](#)).

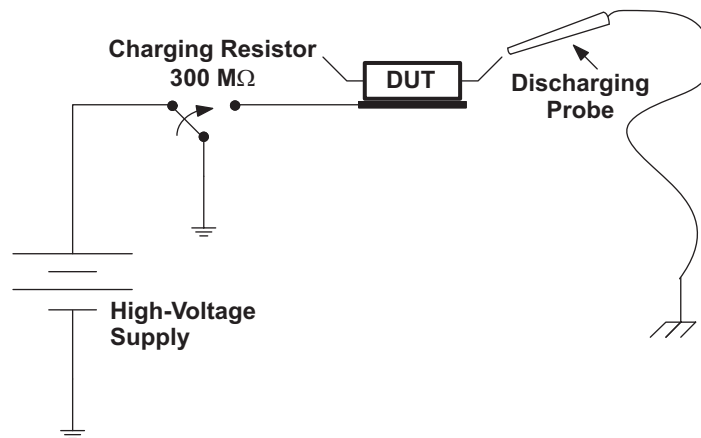


Figure 2. Charged Device Model (Similar to the JEDEC JESD22-C101 Specification)

NOTE: These component-level ESD standards apply to unpowered devices and are an indicator of device susceptibility to ESD events in a manufacturing environment. Texas Instruments does not ensure system-level ESD ratings such as IEC 61000-4-2 for the MSP430 family of devices. For system-level ESD protection guidelines and recommendations, see the following section.

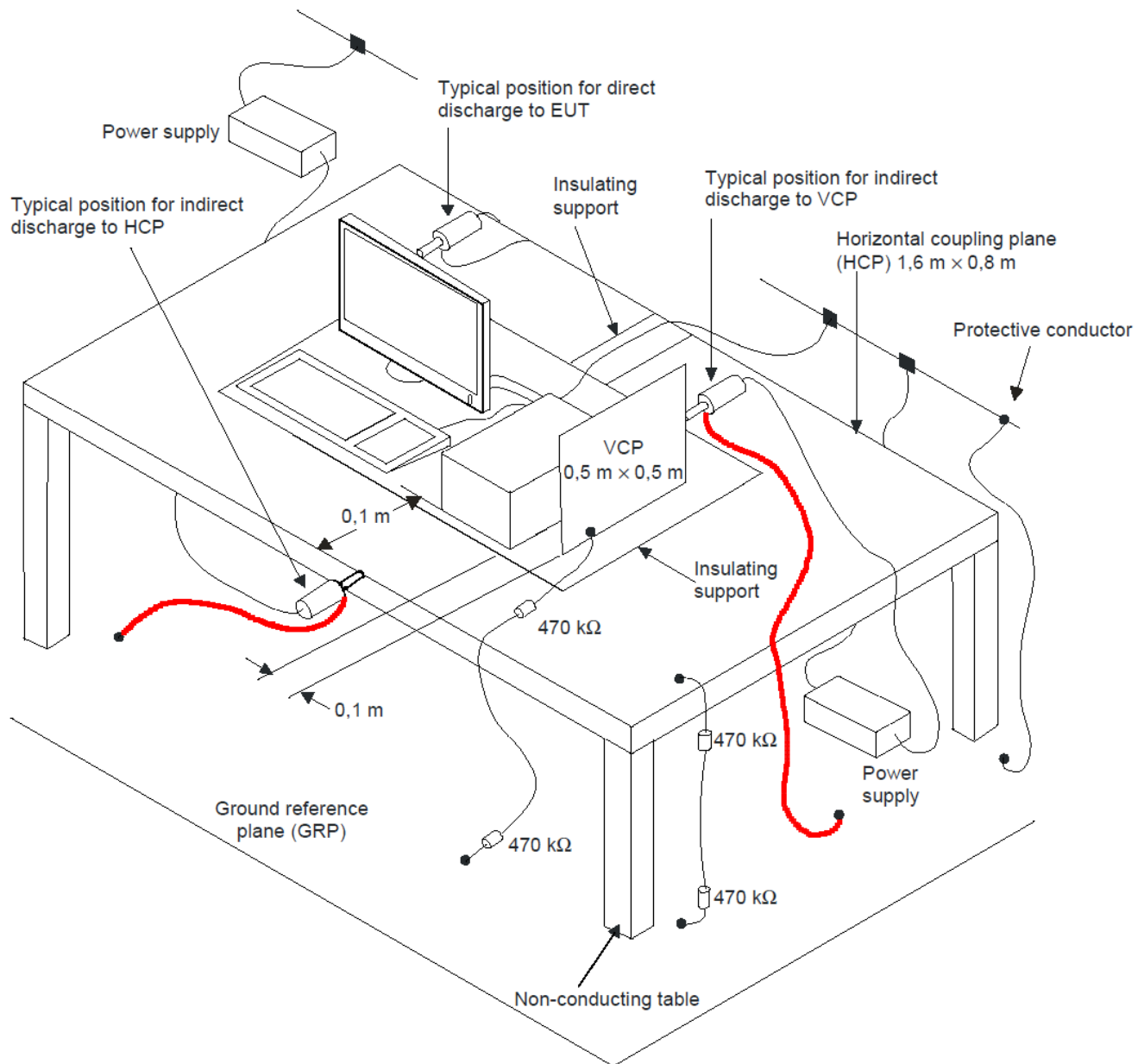
1.2 System-Level ESD Rating

Typically in ESD protected areas (EPA), the ESD voltage levels are low due to ESD-control measures as standardized by ANSI/ESD S20.20 [13] and IEC 61340 [14] that are followed world-wide during assembly, packaging, and other production processes. The same cannot be assured when the end-product ships and reaches the hands of the customer. A consumer product deployed to the field is usually handled outside of an EPA and can be subjected to higher-voltage ESD strikes.

The IEC 61000-4-2 is recognized industry-wide as the standard for end-product ESD rating. The primary purpose of IEC 61000-4-2 test is to determine the immunity of systems to external ESD events during operation. It relates to equipment, systems, subsystems, and peripherals without further defining them. Its scope and description clearly indicate the purpose: to test electrical and electronic equipment that may be subjected to ESD from operators directly or from personnel to adjacent objects [1]. It additionally defines ranges of test levels, which relate to different environmental and installation conditions and establishes test procedures.

The system-level IEC current discharge curve is more severe than the HBM test and is generated from a hand-held unit (sometimes identified as ESD gun). The method targets both direct and indirect ESD events between a person and a piece of equipment. Direct discharges are applied to metal locations accessible to persons during normal use of equipment and indirect discharges are always done by contact discharge to a coupling plane. Contact discharge mode is the preferred IEC test method, and only insulated covers and connector pins with a plastic shell are stressed with air discharge.

In contrast to the automotive ESD standard ISO 10605 [6], the ESD generator is connected to the Ground Reference Plane (GRP). The indirect discharge part of the test uses two other planes: Horizontal Coupling Plane (HCP) and Vertical Coupling Plane (VCP) that are connected to the ground plane with two 470-kΩ resistors. Discharges to these planes simulate the stress caused by the radiated field from real-life discharges to nearby objects. This test setup is shown in Figure 3.



NOTE: The ground connections of the ESD gun are highlighted in red.

Figure 3. ESD Test Bench for Powered Condition From IEC 61000-4-2 [1]

Table 2 lists the IEC 61000-4-2 test specifications.

Table 2. IEC 61000-4-2 Test Specifications [1]

Test Parameter	IEC 61000-4-2	
	Contact	Air
Discharge Type	Contact	Air
Output Voltage	2 kV to 8 kV	2 kV to 15 kV
Interval Time	Minimum 1s	
Polarity at Each Stress Voltage Level	Positive and negative	
Network Capacitance	150 pF	
Network Resistance	330 Ω	
Number of Discharge Pulses	Minimum 10	
Test Condition	Powered	

When testing a system to this or similar system-level standards, the end-products are required to remain functional in the presence of or following an ESD event. The IEC specified system-level failure criteria classifications are as follows:

- Normal performance within limits specified by the manufacturer.
- Temporary loss of function or degradation of performance that ceases after the disturbance ceases. Equipment under test recovers its normal performance without operator intervention.
- Temporary loss of function or degradation of performance. Recovery requires operator intervention.
- Temporary loss of function or degradation of performance which is not recoverable, caused by damage to hardware or software, or loss of data.

It is clear that most of above categories don't relate to physical device damage, but rather system upsets. The acceptance criterion for any particular system or application is specific to that case. Therefore, the board designers and OEMs should handle the system-level ESD robustness by taking necessary precautions to prevent or minimize ESD coupling into the system or device (either directly through device pins or via connected cables) that develop errors on signal traces or damages the device itself.

The later sections in this document highlight a few general guidelines that can help create an ESD-robust system solution. Too often ESD testing is carried out as an after-thought and board designers and OEMs find themselves failing IEC-type tests because they have not taken the necessary precautions while designing their application. Hence, board designers and OEMs are encouraged to see this document and numerous published materials available with regards to ESD safety before starting their design.

1.3 ESD Waveforms

When an electrostatically charged object is discharged, the resultant discharge current consists of a very fast edge followed by a comparatively slow bulk discharge curve. The current discharge curves associated with the different component-level ESD models (HBM, CDM) and the system level models (IEC 64000-4-2) differ significantly.

The standard HBM current waveform has a specified rise time between 2 and 10 ns, while the CDM rise time is typically in the range of 50 to 500 ps, depending on the effective device size and capacitance, and the IEC initial pulse has a rise time between 0.6 to 1 ns, while the secondary larger total energy pulse has a rise time between 10 and 20 ns. These current discharge differences are critical to the effectiveness of on-chip protection structures in terms of hardware failure or physical device damage. Most on-chip ESD protection elements are dependent on the rise time of the initial pulse for turn-on response, in addition to the total power and peak current handling capability. Thus, they can be expected to perform differently for different model stresses [2]. This implies that the on-chip ESD protection that is designed to cater to IC-level ESD standards (like HBM, CDM) cannot accommodate for ESD stress at the system level to ensure prevention of physical device damage and other system upsets; and this should be handled at the system level by the board designer or OEMs.

Also, the amount of energy in an IEC pulse is much higher than in an IC level HBM or CDM pulse, as is the peak current. In addition, the frequency spectrum is different. IEC includes high frequency components comparable to CDM, lower frequencies comparable to HBM and everything in between. Even if the exact applied IEC waveform is well defined, the waveform reaching the IC in a particular system is unknown [2] and, therefore, the functional or application ESD failure is system specific.

If the on-chip ESD protection circuitry has to accommodate for the complete system-level ESD stress, then it must be able to sink much higher energy levels at much faster transients and much higher peak currents. The resulting impact on chip size and the overall cost of the device would be less economic compared to including protection at the component or system level by the board designers and OEMs.

Figure 4 shows the model-specific current waveforms.

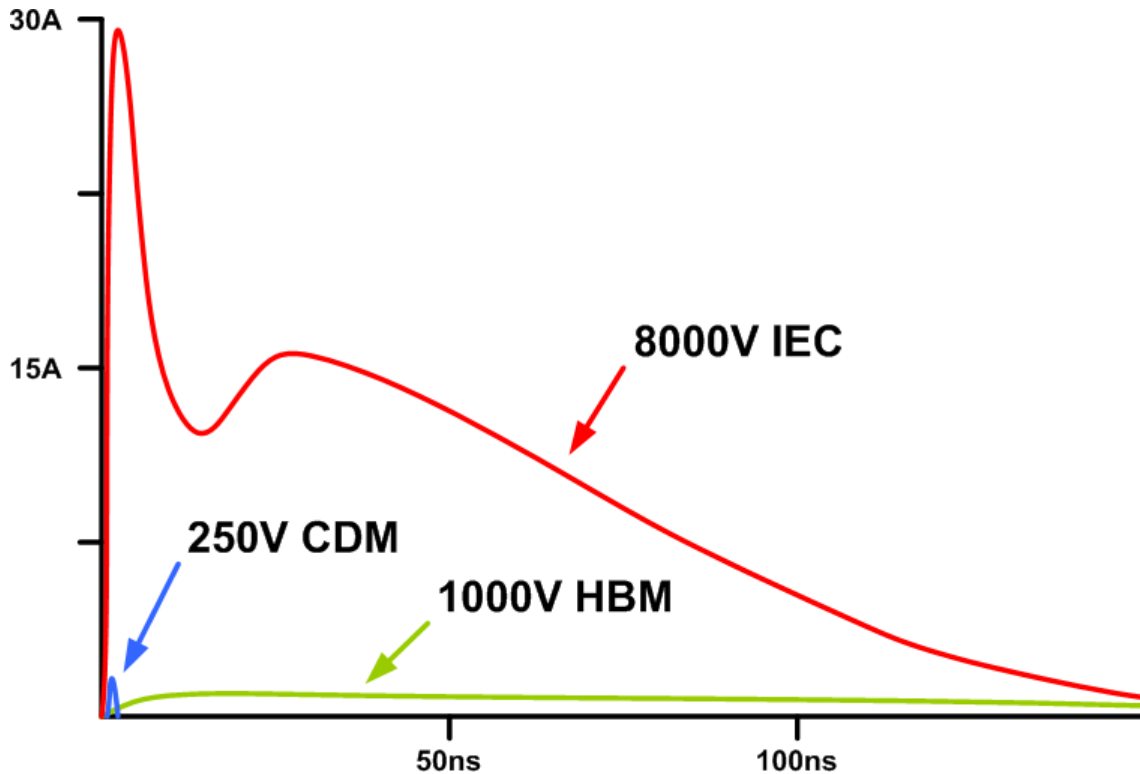


Figure 4. Comparison of Standard HBM, CDM, and IEC Discharge Pulses

NOTE: With the rapidly advancing silicon technology, increasing data rates, and improvements in manufacturing ESD controls and awareness, the Industry Council on ESD Target Levels [15] has concluded that HBM levels of 1 kV and CDM levels of 250 V are sufficient for component-level ESD rating while still keeping ICs safe during production and assembly [9, 10]. Texas Instruments, as a member of the Industry Council on ESD Target Levels is moving towards incorporating these HBM and CDM levels.

2 General System-Level ESD Design Guidelines

System-level ESD protection strategies depend strongly on physical design, operational requirements and overall cost of the end-product. There are different disciplines of protection that can be considered to minimize ESD coupling into the system. A robust ESD system design involves factoring multiple elements such as:

- Enclosure
- PCB design and layout
- ESD ground paths
- On-board ESD protection devices
- System wiring and interconnects
- Software design
- ESD testing

The key to an ESD-robust system design is to consider the effects of ESD in the system early on during design and development of the board by following ESD-immune design guidelines. ESD testing throughout development helps identify and fix weak ESD spots in the system through different stages.

2.1 Enclosures

Identifying the ESD entry points in the system and designing enclosures such that any direct or indirect electrostatic discharge into the system is minimized, is key to any system-level ESD protection design. [Figure 5](#) shows various enclosure cases and respective ESD entry scenarios.

[Figure 5\(a\)](#) represents an ideal case where the conductive enclosure is properly shielded and grounded; ESD does not influence the system at all. This is an ideal case, but it is not applicable in most systems.

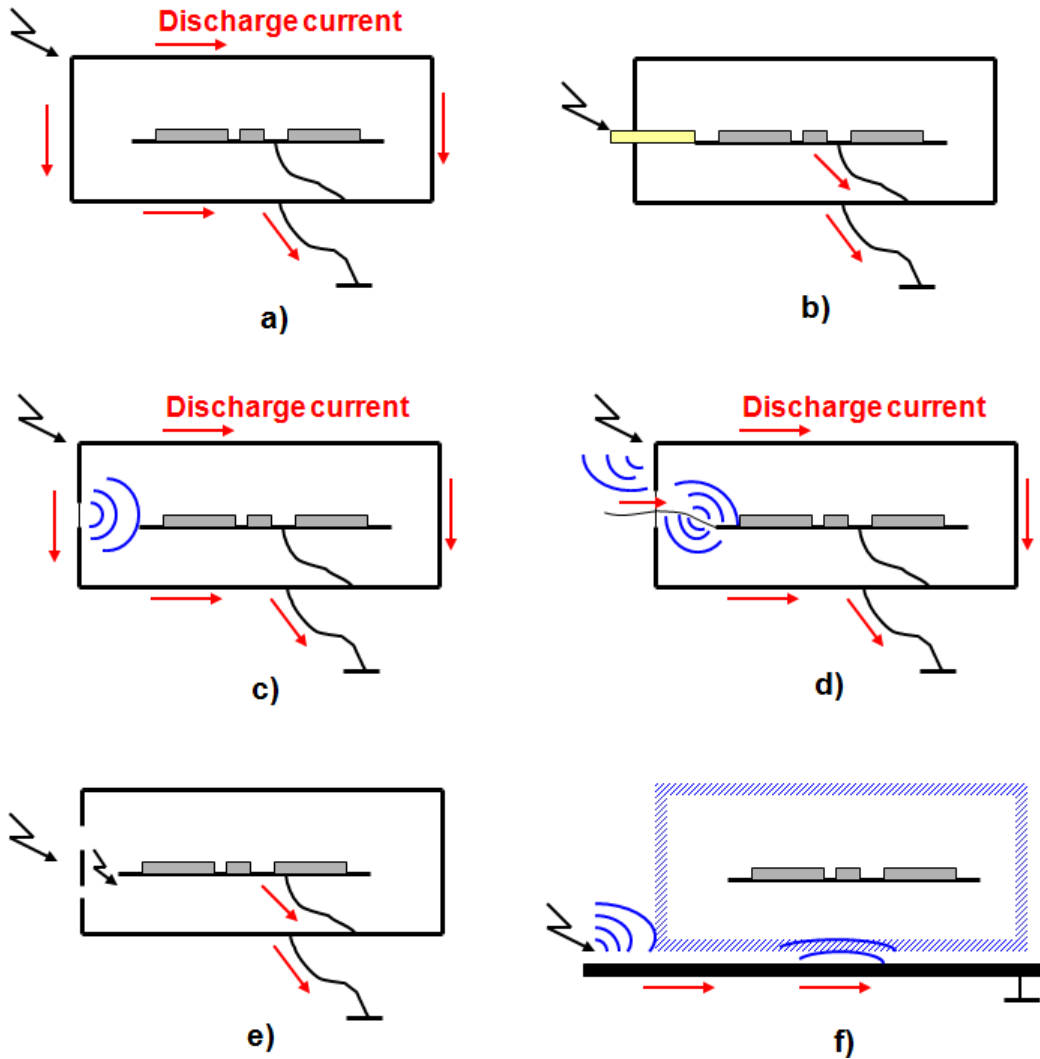
[Figure 5\(b\)](#) represents the direct discharge case where a conductive block in the system is protruding out of the enclosure and the electrostatic discharge gets coupled onto the system right through this block. A good design would make sure that the conductive block penetrating out of the enclosure is properly shielded to minimize ESD coupling.

[Figure 5\(c\)](#) represents the indirect discharge case where the electromagnetic fields that are generated enter the system through the enclosure holes. These electromagnetic fields can couple to internal circuits or wires and propagate through the system. Providing sufficient air gap between the enclosure holes and the electronics within the enclosure can help minimize this coupling effect.

[Figure 5\(d\)](#) represents direct discharge to cables that in turn generate electromagnetic fields in the system. See [Section 2.1.2](#) for recommended design guidelines.

[Figure 5\(e\)](#) represents secondary discharge from isolated metal bracket or panel that gets coupled to the system. See [Section 2.1.1](#) for recommended design guidelines.

[Figure 5\(f\)](#) represents electrostatic discharge close to a plastic enclosure that generates an electromagnetic field. Keeping sufficient air gap between the non-conductive enclosure and the electronics within the enclosure can help minimize electromagnetic noise coupling into the system.



- (a): Ideal case
- (b): Direct discharge
- (c): Electromagnetic influences through holes
- (d): Direct discharge to cables
- (e): Secondary discharge from isolated metal
- (f): Discharge close to plastic case

Figure 5. Enclosure Scenarios

2.1.1 Enclosure Openings

The following are general enclosure guidelines that can help to minimize ESD and EMI coupling onto the system (a PCB, in this case):

- Provide direct ground path to conductive enclosures to minimize ESD coupling into the system. The direct ground path should be short with a low inductance.
- Choosing plastic and other non-conductive enclosures, air space and insulation can prevent ESD arcs from penetrating inside the system.
- Keep sufficient air gap between points on the enclosure that are susceptible to ESD (including ventilation holes, mounting holes, seams, and so on) and the PCB.
- Choose switches and user controls with plastic shafts or cover metal shafts with plastic knobs
- With plastic being used as the enclosure material, LEDs and LCDs that are exposed through the non-conductive cases form a direct discharge path to the system. This is less severe in cases where the enclosure material is metal, as an ESD would arc to the metal case instead of the LED or LCD. In cases where the plastics is used as the enclosure material, because there is no metal panel available, the ESD would arc the exposed LEDs or LCD and their leads connected to the system directly. This discharge path can mostly be avoided by:
 - Using gaskets around LCD openings in the enclosures
 - Shielding LEDs that are exposed on plastic enclosures with transparent and non-conductive lens covers (see [Figure 6](#))

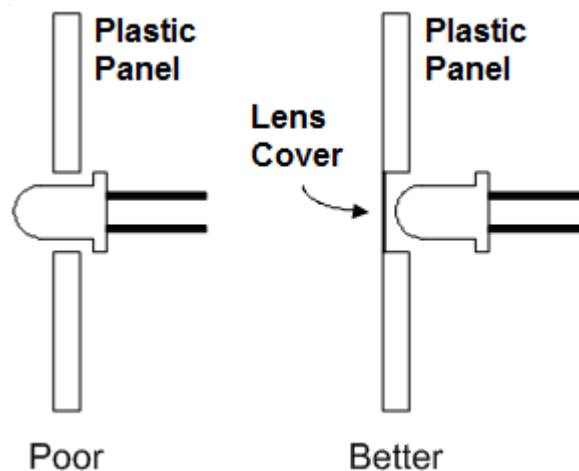


Figure 6. Shielding LEDs

- Upon direct discharge to enclosures with an isolated metal bracket or panel (which represent a high-impedance path to ground), (1) secondary discharge occurs within the enclosure, thus coupling the ESD to the PCB; and (2) high-frequency electromagnetic noise is generated and can couple onto the internal wiring or PCB. A good design should properly ground the isolated metal brackets to minimize ESD or EMI coupling.
- Physical Opening: Reduce the overall aperture of the physical opening in the enclosure to minimize ESD coupling or electromagnetic noise coupling onto the system within (see [Figure 7](#)).

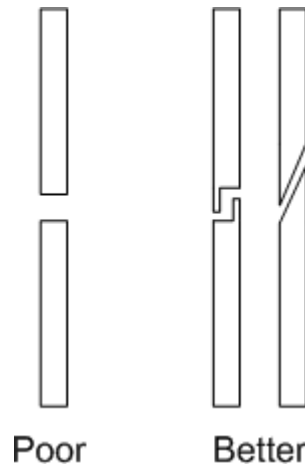


Figure 7. Enclosure Opening Considerations

- Beneath plastic bezels: Air discharge can reach metal back-plates beneath the plastic bezels and generate secondary discharges that can couple to the PCB behind. In this case, spraying conductive coating to the back of the plastic bezel can help direct the discharge to the enclosure ground and minimize ESD coupling onto the system.

2.1.2 Enclosure Cables

ESD can arc to the connectors on the cables, while indirect ESD can couple into cables through induction or radiation. General enclosure cable guidelines that can help to minimize ESD coupling onto the system (PCB in this case) are as follows (also see [Figure 8](#)):

- Shield connector cables to reduce coupling (use foil or foil and braid shields).
- Keep cables as short as practicable.
- Properly ground cables entering the enclosure.
- Use transient suppressors and filters at cable entry points.

The "Best" case in [Figure 8](#) shows use of varistors as discharge suppressors at the cable entry points.

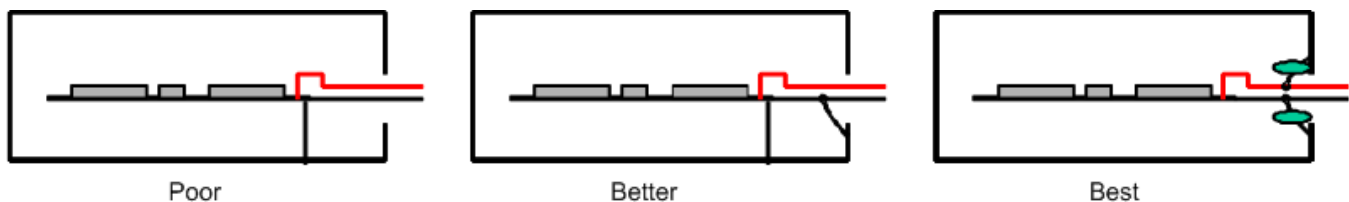


Figure 8. Enclosure Cable Considerations

2.2 PCB Design and Layout

Good PCB design and layout can be extremely effective in suppressing ESD in the system. These are general guidelines for ESD- and EMI-immune PCB layout:

- Use ground planes instead of ground traces where possible to lower the current-path inductance.
- Use multipoint and thicker grounds where you want ESD currents to flow, and single-point and thinner grounds where you don't.
- If it is not practicable to create a continuous ground plane by using copper pour in the layout, then create smaller copper pour sections that are in turn connected to the rest of the ground. However, do not create isolated copper pour islands; they can induce noise and arc in presence of ESD.
- If possible, use multi-layer PCBs with paired power and ground planes.
- If possible, place solid or filled vias into power and ground planes. These vias provide excellent

thermal dissipation in case of an ESD event and also ensure good electrical and power supply connections. For the plated through-hole components, use thermal vias.

- Keep traces as short as possible to reduce trace inductance.
- Avoid routing traces at right angles to component pins or other traces. Right angle traces should be avoided as they are known to cause more radiation. This becomes more critical in high-speed designs.



Figure 9. Avoid Right-Angle Traces

- Keep sensitive signal traces away from PCB edges.
- Place all connectors and external wires on one edge of the PCB.
- Place ESD susceptible circuitry at the center of the PCB (away from the edges of the board, external wires, connectors and power).
- Decoupling (see [Figure 10](#))
 - Use decoupling capacitors with low effective series resistance (ESR) and effective series inductance (ESL) to decouple the IC (MSP430 in this case) power from the rest of the supply system.
 - Place the decoupling capacitor close to the IC power pins.
 - Keep the traces from decoupling caps to GND as short (and thick) as possible.

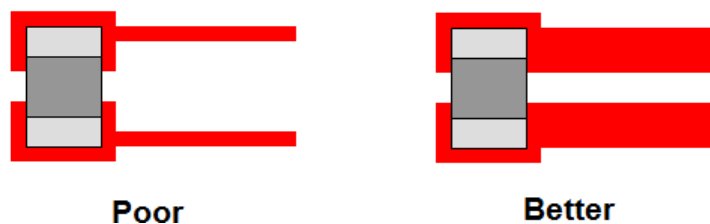
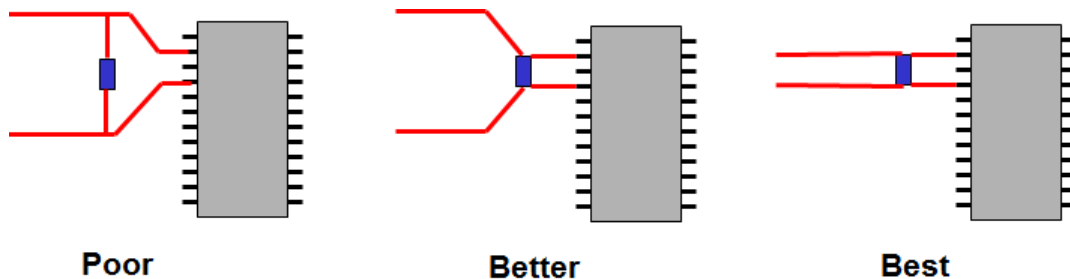


Figure 10. Decoupling Basics

- Crystal layout

Crystal connections on PCB layout are very important as crystals are susceptible to ESD and EMI noise in the system. Poor designs can cause the crystal to dropout or cause jitter in the crystal oscillator clock. These are general guidelines for ESD-immune PCB layout practices:

- Crystal should be placed as close to the MSP430 as possible
- The traces connecting the crystal should be short and direct
- Ensure no traces run beneath the crystal
- Keep switching signals away from the crystal layout to avoid causing crystal dropout (see Section 5 for real world example based on this)
- Keep a clean ground plane beneath the crystal
- Ground the crystal can as well; use guard rings around the leads

Figure 11 shows an example crystal layout that follows all of these design recommendations.

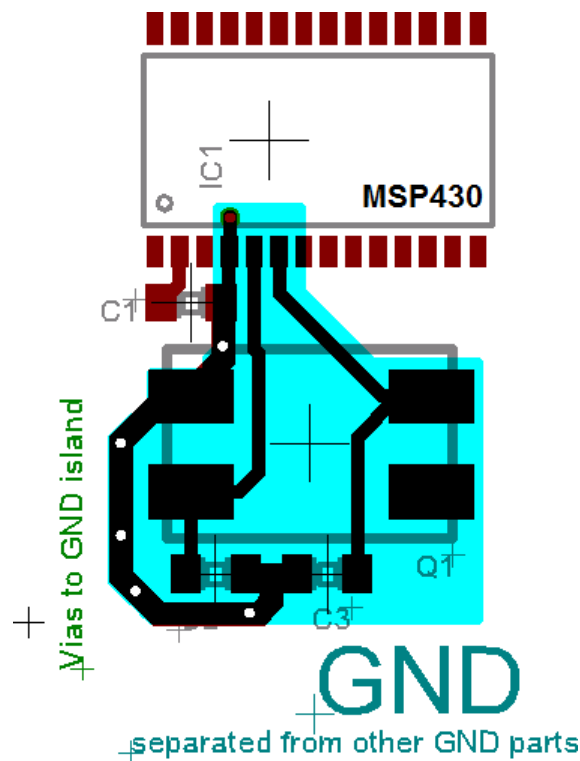


Figure 11. Example Crystal Layout

This topic has been discussed in greater detail in *MSP430 32-kHz Crystal Oscillator* ([SLAA322](#)) [11]

- Current Loops

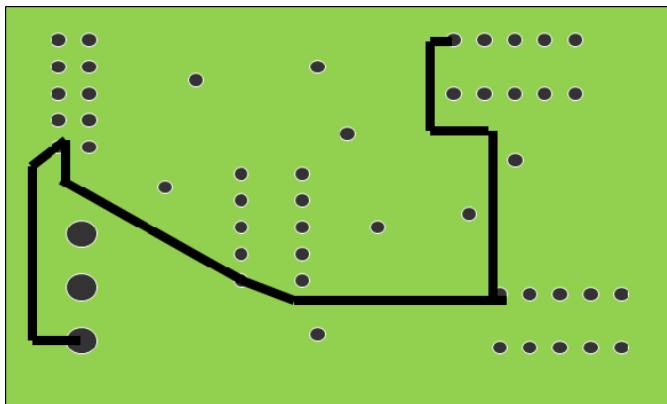
An electrical circuit is always a closed loop. Every signal path has a return path back to the source; also called the return current. With DC, the return current takes the lowest resistance path back. With higher frequency, the return current flows along the lowest impedance; that is directly beneath the forward signal path [12]. Current loops in the layout generate noise and should be minimized by keeping forward and return currents together. It helps both EMI and ESD performance. Solid ground plane provides continuous, low-impedance path for return current.

- For a two-layer board, try to dedicate one layer as mostly solid ground plane, with routing slots cut out for signal traces
- [Figure 12](#) shows a solid ground plane. Only breaks in the plane are vias and through-holes. This is the ideal case.

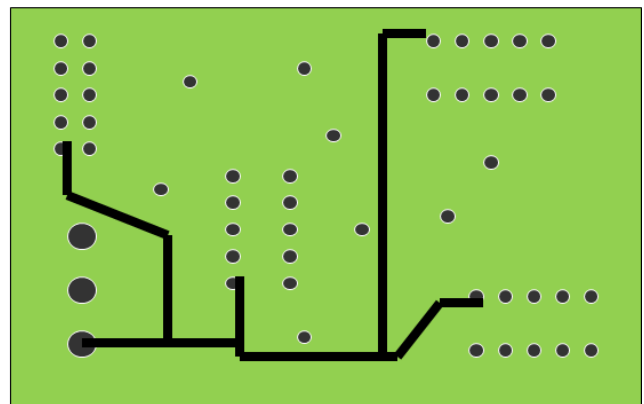


Figure 12. Example Layout With Solid Ground Plane

- If one of the layers cannot be dedicated as ground plane, then use a star configuration instead of a daisy chain configuration to connect all grounds. Daisy chaining forces all the signals to follow the same return path possibly causing ground bounce.



**Poor
(Daisy Chain Configuration)**



**Better
(Star Configuration)**

Figure 13. Grounding Considerations For 2-Layer Board With No Dedicated Ground Plane

- Make sure that no traces on the other layer perpendicularly cross a break or slot in the ground plane. Otherwise, it forms a large inductive loop that can generate and pick up noise. If the return path, particularly the ground plane, has a break or slot, the return current must take a different route, and this results in a loop area (see [Figure 14\(a\)](#)). The larger the loop area, the more radiation and EMI problems occur.

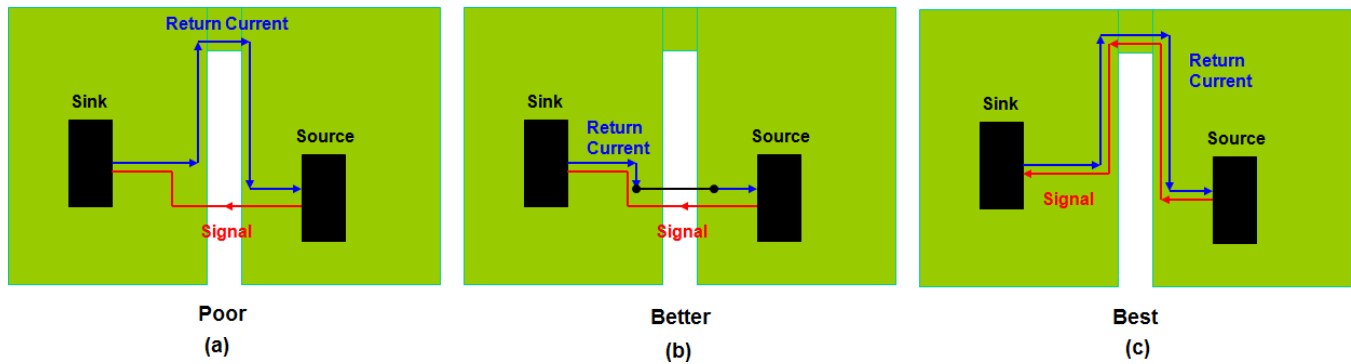


Figure 14. Return Currents and Resulting Loop Area

- The designer must make sure that the return current flows directly underneath the signal trace. One way is to physically connect the areas separated by the slot (for example, by placing a 0- Ω resistor over the slot) [Figure 14\(b\)](#). Another way is to route the signal same way as the return current flows [Figure 14\(c\)](#) [12]. This is also the best way here.
- Keep loop areas between power and ground as small as possible (see [Section 2.2.1](#) for example layout discussion illustrating this).
- Keep loop areas of switching signals as small as possible.
- Keep loop area of oscillator signals as small as possible.

2.2.1 Example Layout – Current Loop

[Figure 15](#) shows an example 2-layer PCB layout (both top and bottom layer shown) in which the VCC signals' forward and reverse currents have been marked in black and green respectively. It is shown in the figure that a large VCC current loop is formed and, due to this, every trace within the loop area is affected by the noise generated by the loop itself.

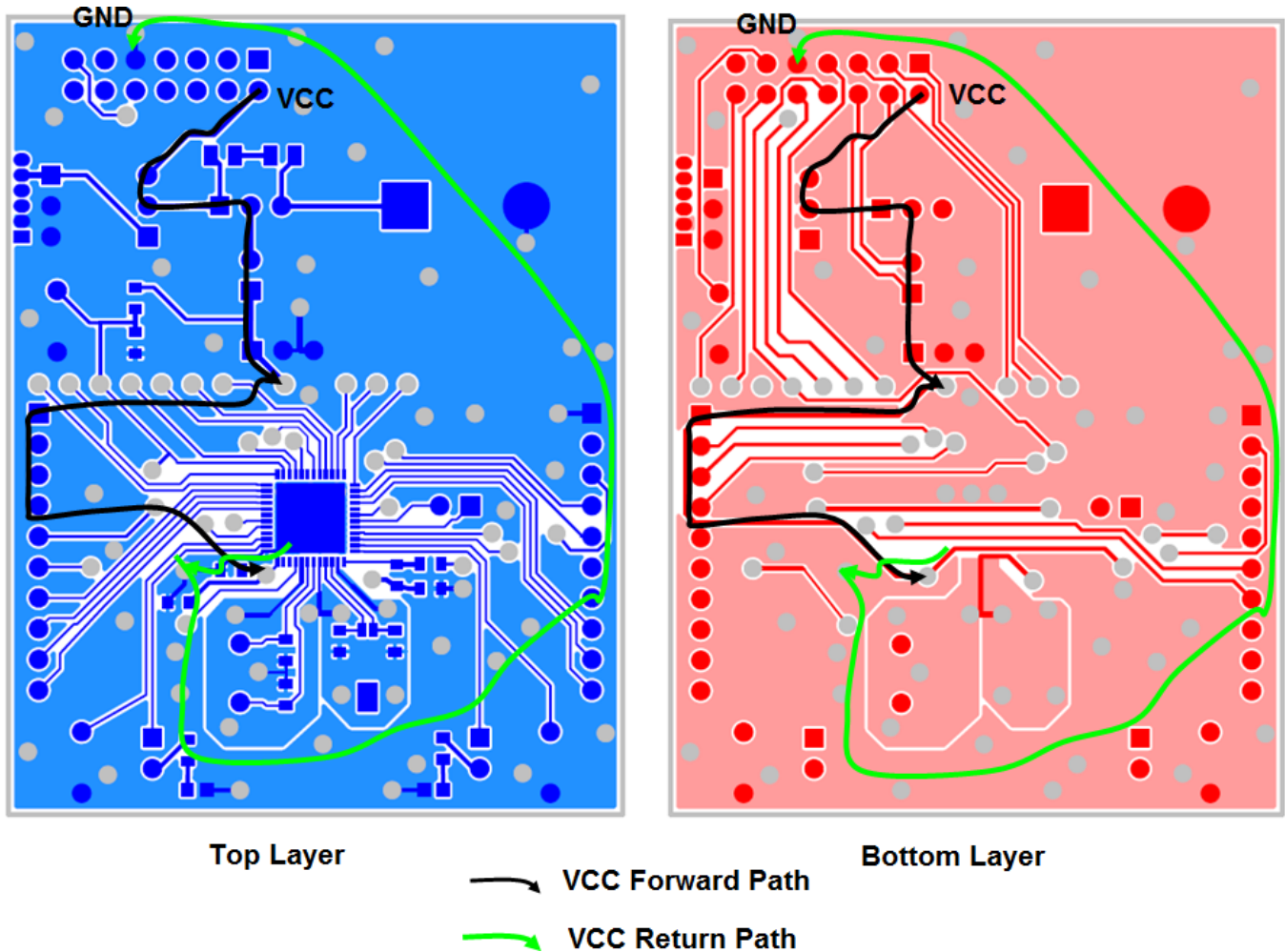


Figure 15. Example 2-Layer PCB Layout Showing Large Current Loop

The next revision of the board has been designed with a mostly continuous ground plane on the bottom layer with very short traces. The bottom ground plane allows for the VCC reverse current to follow the forward path, thus minimizing the overall current loop. See [Figure 16](#) that shows the top and bottom layers of the revised board.

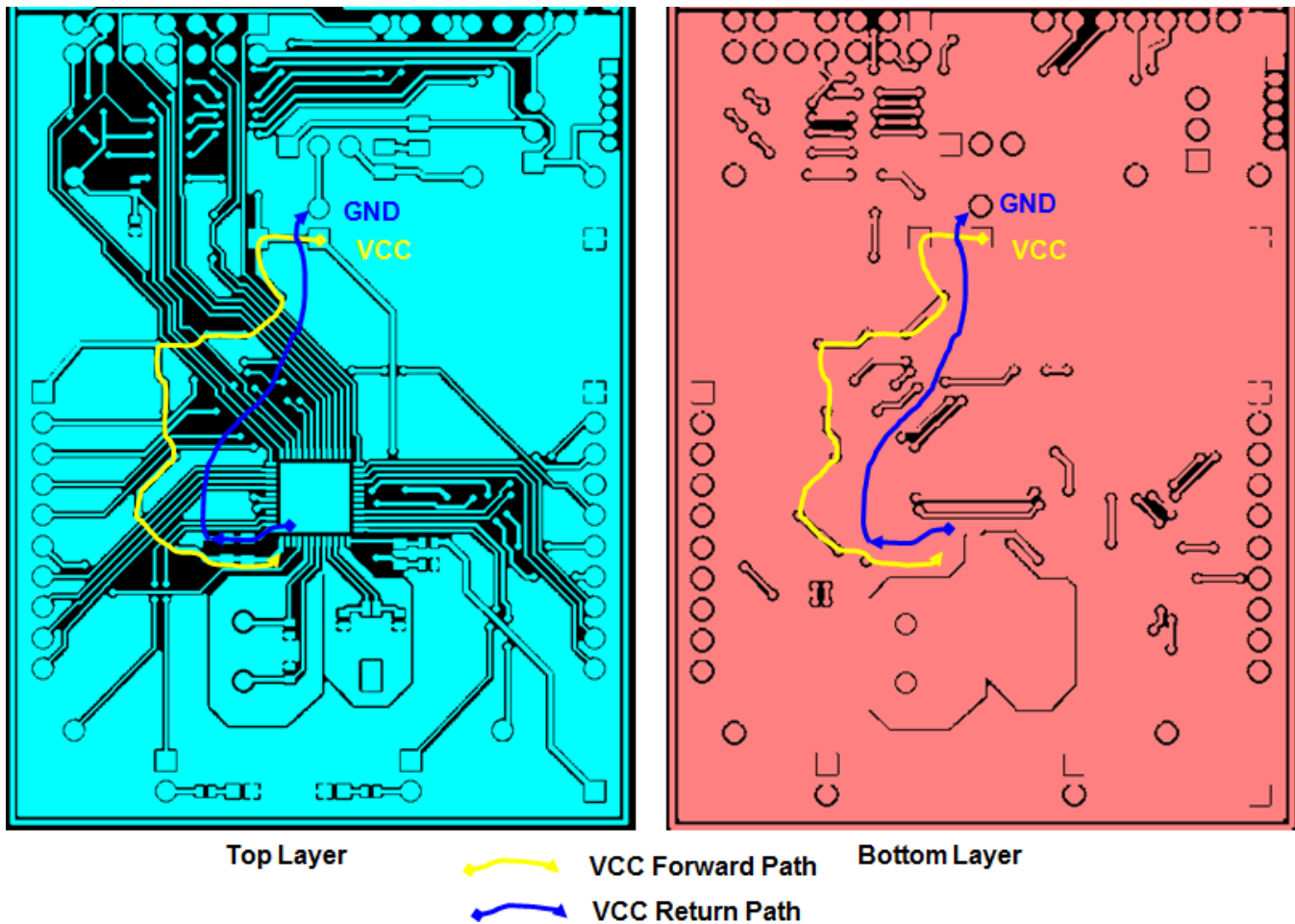


Figure 16. Example 2-Layer PCB Layout Showing More Continuous Ground Plane And Reduced Current Loop

2.3 On-Board ESD Protection Devices

External ESD protection components include passive components like series resistors, decoupling capacitors, ferrite beads, suppression devices such as filters, transient voltage suppressors (TVS), varistors, thyristors, diodes, polymers, SCRs, and so on. These components block ESD currents, clamp ESD-induced voltages and shunt ESD-induced currents in the system, thus minimizing the effects of ESD pulses in the system.

Here are some general guidelines towards choosing on-board ESD protection devices that help to minimize ESD effects in the system.

2.3.1 Simple Passive Components

- Use series resistors to attenuate indirect or secondary ESD stress in the system. Series resistors have proven to be very effective for system-level ESD protection and they can be used with voltage clamps and decoupling capacitors.

NOTE: If series resistors are forced to conduct currents from direct ESD events, very large voltages can build up across these resistors causing arcs between the terminals which, in turn, can short these series resistors. Therefore, for handling direct discharges in the system use primary clamping devices (TVS devices) in addition to the series resistor or use resistors designed for high voltages (which usually come in a larger footprint).

- Use capacitors to provide simple decoupling. Choose capacitors with high-voltage rating, high resonant frequency, low resistance (ESR), and low inductance (ESL). Minimize leads and trace lengths connecting the capacitors on the PCB.
- Use LC filters to block transients and EMI entering or exiting the system.
- Use ferrite beads to attenuate EMI and ESD.

These passive components should be placed as close as possible to the potential ESD stress points in the layout

NOTE: Small SMD passive components usually do not provide good protection against direct 8-kV IEC pulses but they can be used to protect against secondary pulses in the system [2].

2.3.2 ESD Suppression Devices

- Identify the maximum capacitance that can be applied to signal lines in the system and place appropriate filters or TVS on sensitive signals (like resets, interrupts, edge triggered signals, and so on)
- Place filters or transient suppressors on off-board receivers and drivers for cables that are susceptible to direct discharge (including signals that enter opto-isolators)
- Choose protection components for the system based on clamping voltage levels achievable, breakdown voltage, response time, capacitance, dynamic resistance and ability to withstand multiple ESD strikes. Texas Instruments offers a wide range of ESD and EMI protection devices and solutions; for more information regarding the ESD and EMI protection product portfolio, see [Reference \[5\]](#).

TVS Diodes

TVS diodes have lower capacitance and lower dynamic resistance values compared to other transient suppression devices. They demonstrate high ESD multi-strike absorption capability; that is, once the ESD strike is absorbed, the protection device returns to its high-impedance state very quickly. These devices offer very low clamping and breakdown voltages and have excellent response times.

Varistors

When an ESD event occurs, the varistor resistance changes from a very high standby value to a very low conducting value, thus absorbing the ESD energy and limiting ESD-induced voltages. Varistors typically have trigger voltages over 50 V, clamping voltages over 100 V, and a dynamic resistance over 20 Ω (after turn on) [2]. They feature lower capacitance but have significant leakage currents after an ESD stress.

Polymer

These devices are similar to varistors in operation but have very low capacitance (0.05 to 1 pF) making them a good fit for high-frequency applications. The breakdown voltages are higher (compared to varistors) and have lower endurance to multiple ESD strikes.

2.3.3 ESD Protection Using Series Resistor

Consider a system where an MSP430 IC is interfaced to an LCD that is susceptible to ESD (secondary or residual ESD stress in the system). In this case, LCD pins represent the ESD entry points in the system; so, it is recommended to place series resistors on the LCD pins. When an ESD event occurs in the system, the series resistor limits the current that finally strikes the MSP430 I/O pin. The larger the value of resistance, the lower is the residual current seen at the interface I/O pin.

NOTE: If standalone resistors are used for primary ESD protection, they must withstand the full electrostatic voltage. This requires resistors that are designed for high voltages, and these usually have a larger footprint.

The series resistors can be combined with additional diodes and primary clamping devices for added protection (see the equivalent circuit shown in [Figure 17](#)). The diodes at the I/O pins divert the ESD current to the primary clamp (between VCC and VSS), and only the residual stress appears at the device I/O pins. The decoupling capacitor at the supply pins helps limit the initial fast transients of the ESD pulse.

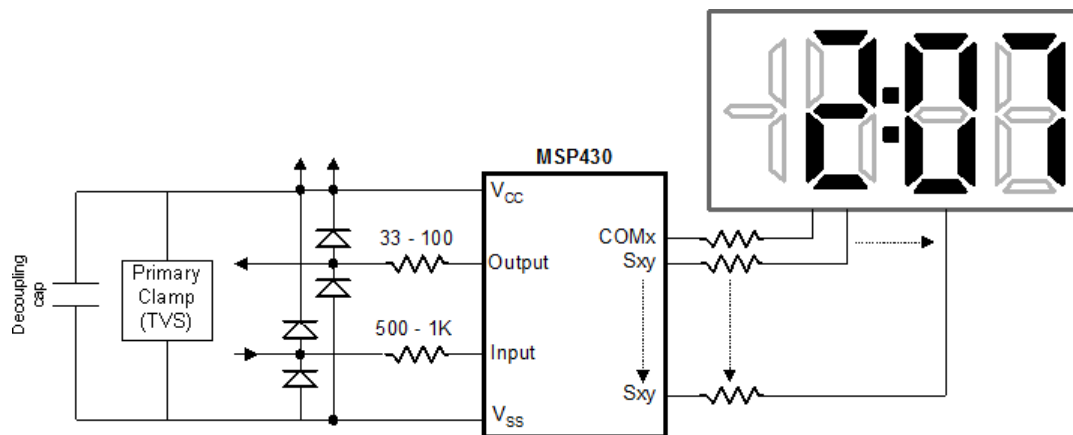


Figure 17. System-Level ESD Protection Using Series Resistors

See [Section 5](#) for a real-world example based on this concept.

NOTE: The simple series resistor protection technique works for low levels of ESD stress (secondary protection of indirect ESD or residual ESD current); however for higher ESD stress (primary protection of direct ESD), suppression devices such as TVS diodes, varistors, and polymers should be considered.

2.4 Circuit Design and Software Considerations

Because the majority of the system-level ESD failures are soft failures (system upset without any physical damage), circuit design and software considerations should be taken to identify and handle these soft failures and also enable for safe recovery. The following sections list general guidelines for circuit design and software considerations.

2.4.1 Circuit Design

- Properly terminate unused pins of the IC (MSP430 in this case).
- Avoid connecting sensitive signals (such as reset, interrupts, or edge-triggered signals) to long traces or cables.
- If possible avoid edge-triggered logic in the system.
- Isolate outside signals by using opto-couplers or transformers.
- If required, include deglitch filters to prevent inadvertent triggers in the system (such as power monitors).
- Allow for the system to reset or recover from deadlock state after an ESD event (for example, by using watchdog timers or nonmaskable interrupts).

2.4.2 Software Considerations

- Use watchdog timer to monitor any software lockups. Ensure software does not stop watchdog timer once started. Design the software or firmware to reset the watchdog timer periodically (preferably in one or two places in the main loop).
- Enable smaller timeouts in functions to identify fault states and regain control (before watchdog timer time-outs).
- Oversample critical hardware inputs and do simple averaging of results to confirm input states.
- Check parity and framing on incoming data.
- Acknowledge reception of correct data; else return error code for incorrect data reception.
- Re-transmit data if acknowledge is not received.

2.5 ESD Testing

ESD testing throughout design and development helps identify and fix weak ESD spots in the system. On-board LEDs and switches can be used to debug different ESD failure categories. Listed below are the different system-level ESD failure criteria as per IEC 61000-4-2 [1] and example failure conditions when using an MSP430 device in the system:

1. Normal performance within specification limits
 - MSP430 is *not* affected by the system-level ESD stress and continues to execute without any intervention.
2. Temporary degradation or loss of function or performance which is self-recoverable
 - Device reset can occur (for example, caused by low pulse on the MSP430 reset pin that causes the device to reset).
 - Oscillator disturbance can occur (for example, caused by on-board crystal dropping out). This condition can be identified by on-chip watchdog or oscillator fault detection.

NOTE: In this case, the on-board LEDs and the reset interrupt vector (that helps identify the last cause of a reset – BOR, POR, or PUC) can be used to identify the failure and recovery conditions

3. Temporary degradation or loss of function or performance that requires operator intervention or system reset
 - Device upset that requires user to manually apply a low pulse on the reset pin or a power-cycle.

NOTE: In this case, on-board switches can be used on the test board to recover the device

4. Degradation or loss of function that is not recoverable due to damage of equipment (components) or software, or loss of data
 - Damage of MSP430 I/O pin structure. This might result in system upsets such as non-operational interrupts associated with the I/O pins.
 - Increased leakage current caused by degradation or damage of integrated components and circuits connected to I/O pins or power supply pins.
 - Loss of CODE or DATA on device RAM or non-volatile memory.
 - Device enters deadlock state by poorly designed software.

See IEC standards [1] for the standard system-level ESD tests, thresholds, and ratings.

3 System Efficient ESD Design (SEED)

System Efficient ESD Design or SEED is a new co-design approach that is introduced in the JEP161 JEDEC publication [2] to limit the damaging current pulses reaching the internal IC pins. It helps to understand the physical effect of an IEC stress applied at the external port of a PCB on the IC pin.

3.1 System-Level ESD Protection Methodology

SEED is a co-design methodology of on-board and on-chip ESD protection that helps analyze and achieve system-level ESD robustness. This design approach requires thorough understanding of the interactions between external ESD pulses, full system level board design and device pin characteristics during an ESD stress event.

3.1.1 On-Board Protection – Primary Clamp

The on-board protection in the system represents the primary system-level ESD protection (also known as the primary clamp) and, as discussed in Section 2, the system-level ESD protection at the PCB level strongly depends on the physical design of the product and its operational requirements. With a good end-product enclosure or cover design, the on-board protection can focus on external connections as well as any cover hole or seam areas that may leak ESD energy inside. The on-board protection circuitry might include clamping components like Transient Voltage Suppression (TVS) diodes, varistors, polymers, and so on.

These primary clamps can shunt large stress currents at low capacitive loads and are effective in reducing the residual ESD stress that eventually appears at the device pins. By characterizing the PCB, a sufficiently detailed RLC network model can be extracted, which allows for simulation of the board that includes the passive components and the ESD voltage clamping elements under system-level ESD stress. This PCB characterization information is system- and board-specific and is critical for the SEED design analysis.

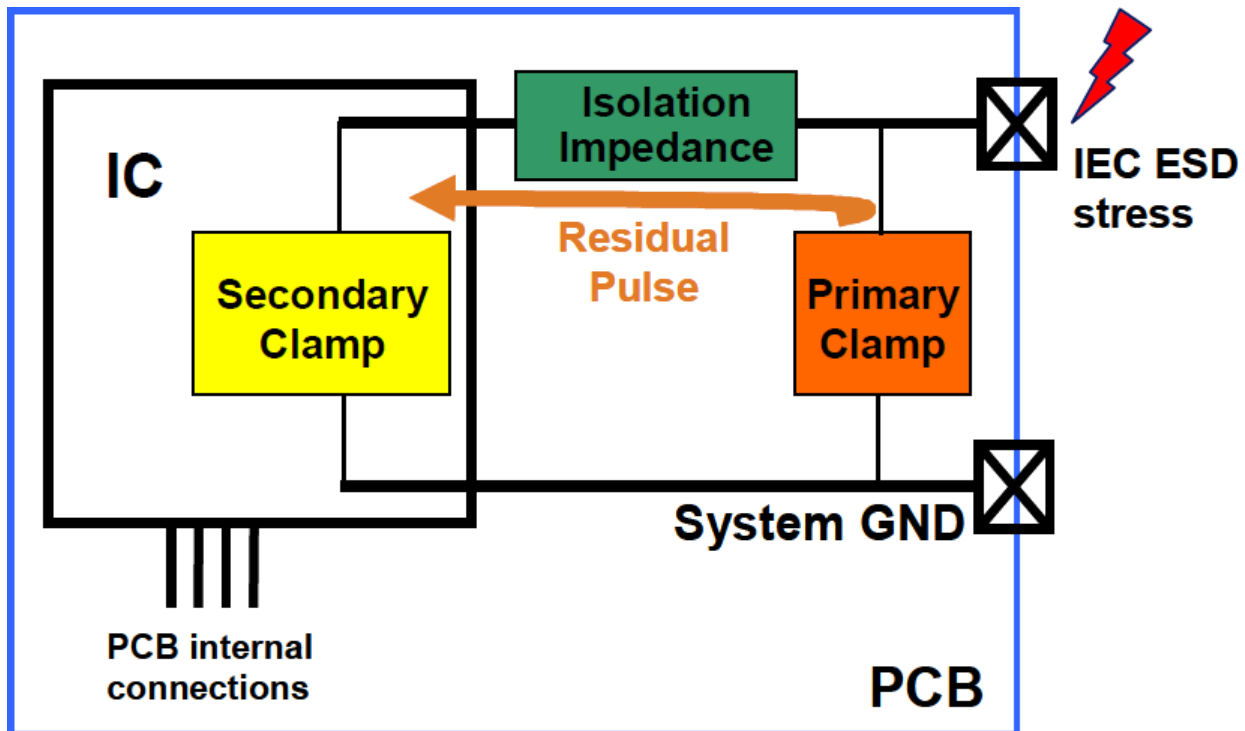
3.1.2 On-Chip Protection – Secondary Clamp

The on-chip protection of an IC pin in the system represents the secondary system-level ESD protection (also known as the secondary clamp), which is used to clamp the residual ESD stress that results at the specific device pins after having passed the primary clamp in the system. Because the shape and energy of the residual ESD pulse is largely dependent on the on-board primary clamp characteristics and the board itself, it is generally unknown. This clearly implies that the on-chip ESD protection alone is not sufficient to overall ensure specified system-level robustness.

The effectiveness of the secondary clamp must be analyzed with respect to the system-specific PCB characterization data and the IC-level I/O characterization data such as Transmission Line Pulse (TLP) parameters to determine if the peak residual ESD voltage and current seen at the specific device pins in the system are within the scope of the on-chip ESD protection capabilities.

3.1.3 Two-Stage Protection – Fundamental SEED Concept

The on-board primary protection and the on-chip secondary protection form the fundamental concept of SEED design methodology and act like the primary and secondary stages of a typical input protection scheme, where the current carrying capabilities of both branches are balanced by a serial impedance [2]. [Figure 18](#) shows this two stage protection scheme with necessary isolation impedance between the primary and secondary protection stages.



NOTE: Matched primary (on-board TVS) and secondary (IC ESD protection) clamps

Figure 18. Two-Stage System-Level ESD Protection [7]

Simulating and analyzing the two-stage protection using the SEED methodology enables board designers to select appropriate on-board protection for primary clamping and other board components (isolation impedance) to ensure peak residual pulse reaching the IC pins (with on-chip ESD protection) can still be handled effectively in preventing any physical device damage and other system level upsets. More information regarding the SEED co-design methodology can be found in the JPEP161 System-level ESD document [2].

In summary, this new co-design methodology concept demonstrates that (1) high-level component-level protection (HBM) does not necessarily ensure effective system ESD robustness, and (2) understanding the interactions between external ESD stress and full system-level design (including ICs in the system) enables achievement of robust system ESD designs with on-chip HBM levels reduced to a more realistic value accepted for IC handling.

3.2 SPICE Simulation Methodology for System-Level ESD Design

This section discusses the SPICE simulation methodology to design an isolation impedance network against the residual pulse from an IEC 61000-4-2 stress using the Transmission Line Protection (TLP) data of on-board TVS components (primary clamp) and the IC interface pins (secondary clamp). The simulation procedure follows these steps:

1. Model the IEC stress waveform

The IEC stress waveform can be modeled by using simple RLC circuits. Figure 20 in Section 4.1 shows an IEC model circuit and the corresponding IEC stress waveform generated. The values of R, L, and C for both branches have to be tweaked to suitably represent the standard IEC stress waveform and are partly based on the well known 330-Ω and 150-pF model [8].

2. Model the TLP behavior of the TVS device

The on-board TVS device (used as a primary clamp in the system) can be modeled for SPICE simulation based on device TLP information, which includes the worst-case breakdown voltage (referred to as $V_{TVS,t1,max}$) and the dynamic on-resistance (referred to as $R_{TVS,on,max}$). The TVS device is modeled by a Zener diode. The $V_{TVS,t1,max}$ defines the breakdown voltage of the zener diode, and the

$R_{TVS,on,max}$ defines the value of the fitted series resistor. See [Appendix A](#) for more details.

NOTE: The TVS device manufacturer should ideally provide the TLP parameters required for SEED methodology in the device datasheet. If wanting to use a TVS device that does not have the necessary TLP parameters made available, then the board designer or OEM has to characterize and model the TVS on their end.

3. Behavior of the interface pin to be protected

A modeling approach similar to that of the TVS device can be used to model the IC interface pin to be protected. The SEED parameters required to model the I/O pin's on-chip ESD protection are derived from TLP measurements and should be provided by the component manufacturer. Using SPICE simulation, the IC pin is represented as a zener diode with a fitted series resistor. The following IC pin ESD protection specifications are used for modeling: (a) minimum turn-on voltage once ESD protection is triggered (referred to as $V_{IC,t1,min}$), (b) maximum acceptable current (referred to as $I_{IC,max}$), and (c) minimum dynamic on-resistance (referred to as $R_{IC,on,min}$). See [Appendix A](#) for more details.

NOTE: As of this writing, Texas Instruments does not characterize or specify SEED parameters for any MSP430 product as a part of the device data sheets. As a member of the Industry Council on ESD Target Levels, Texas Instruments is working on the specification of the parameters needed to support the SEED methodology.

4. Calibrate with measured test board data

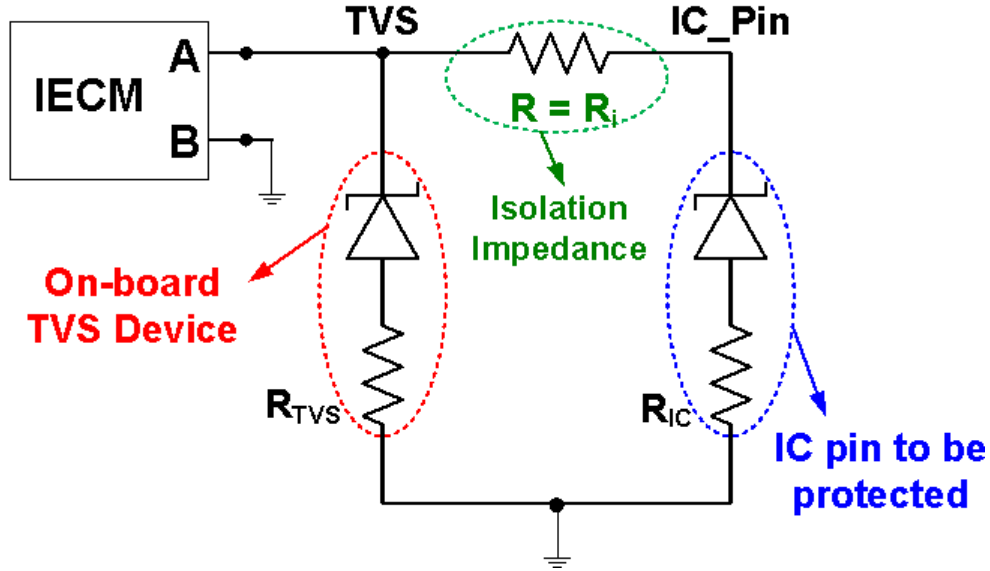
This step includes calibrating the SPICE simulation model based on the test board data. It should accommodate for multi-stage on-board primary clamping (multiple TVS devices) and any additional isolation impedance between the IEC stress point in the system and the IC interface pin.

5. IEC Protection design using SPICE simulation

The IEC protection design using SPICE simulation involves putting together the IEC stress model, TVS and IC interface pin models based on respective SEED parameters and an isolation impedance circuitry. [Figure 19](#) shows an example SPICE simulation of an IEC protection design with a resistor used as the isolation impedance between the primary and secondary clamps.

NOTE: A decoupling capacitor can be connected in parallel to the primary clamp to (1) limit the voltage of the initial fast transient ESD current pulse at the TVS node and (2) limit the voltage slew rate (that is, dV/dt) of this fast transient. Because the response of IC pins to ESD events does not depend on the quasi-static characteristics of the given stress alone but also on its transient characteristics, this decoupling capacitor becomes essential in most system-level ESD designs.

IEC Model



NOTE: Using a resistor as the isolation impedance

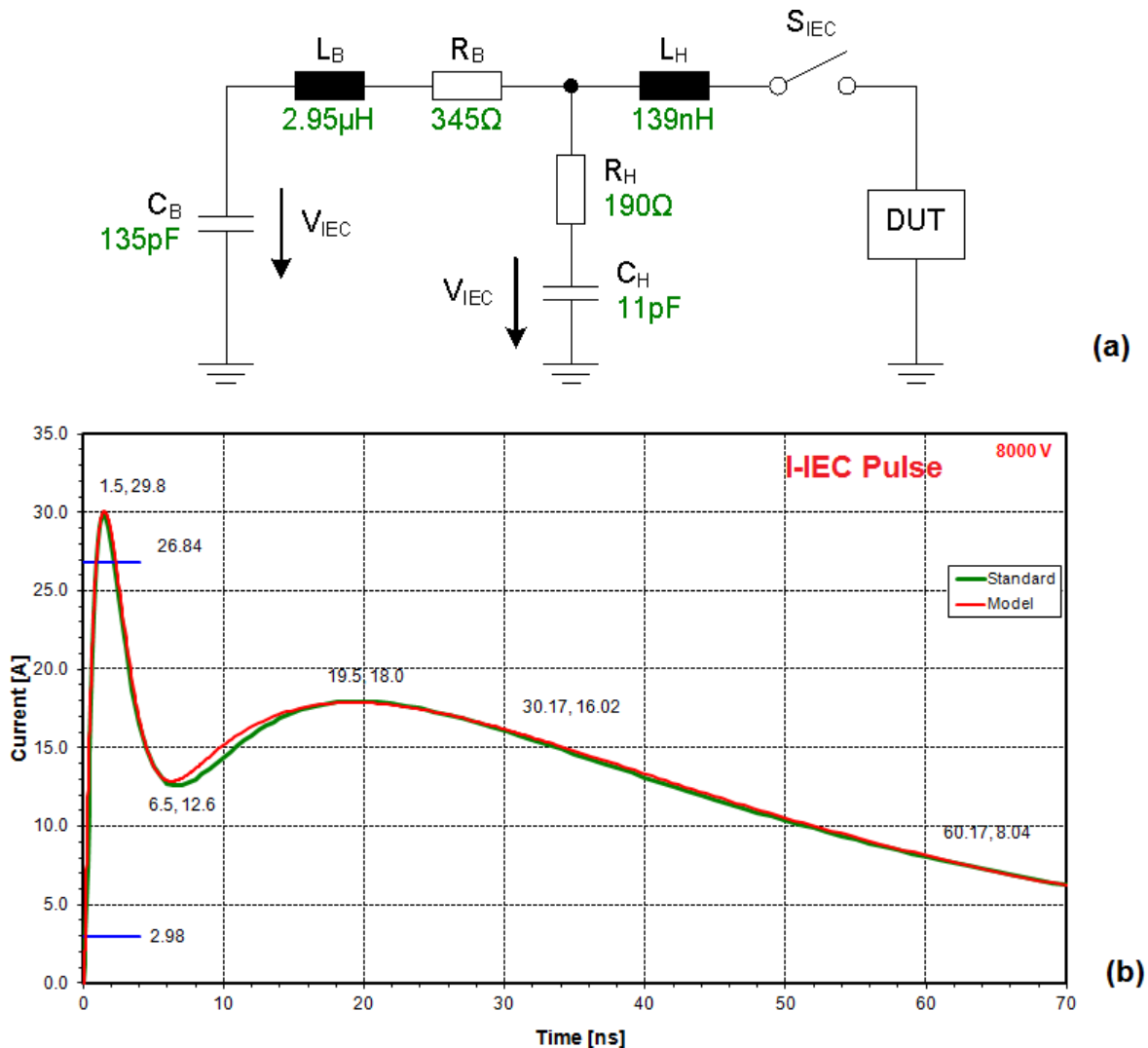
Figure 19. IEC ESD Protection Design Schematic

4 SEED-Based IEC Protection Design and Verification – Real World Example 1

This section shows a real world example of system level IEC protection design and verification that uses a standard TVS device as a primary clamp and a specific MSP430 device interface pin with the on-chip ESD protection as the secondary clamp. The SEED methodology has been applied using SPICE simulations to determine the isolation impedance required in the system to ensure that the peak ESD current and voltage reaching the MSP430 interface pin is within the on-chip protection capabilities. Finally, this analysis has been verified by system-level ESD testing using verification test boards.

4.1 Modeling IEC Stress Waveform

In this example, the IEC stress waveform has been modeled as shown in Figure 20(a). The resulting IEC stress waveform generated is as shown in Figure 20(b).



(a): SPICE based IEC pulse model

(b): The standard and model-generated 8-kV IEC current waveform

NOTE: DUT = Device Under Test

Figure 20. SPICE Simulations

The simulated IEC pulse (see Figure 20(b)) has an initial fast transient peak of approximately 30 A followed by a slow discharging pulse with a peak current of approximately 18 A. This IEC pulse is presented to the primary clamp (TVS device in this example).

4.2 Modeling TVS Device

A single-line ultra-low capacitance bidirectional ESD protection diode with the following characteristics has been used as the standard TVS device for primary clamping:

Characteristics

$T_{amb} = 25\text{ }^{\circ}\text{C}$ unless otherwise specified.

Symbol	Parameter	Conditions	Min	Typ	Max	Unit
V_{RWM}	reverse standoff voltage		-	-	5	V
I_{RM}	reverse leakage current	$V_{RWM} = 5\text{ V}$	-	5	100	nA
V_{BR}	breakdown voltage	$I_R = 5\text{ mA}$	5.5	7	9.5	V
C_d	diode capacitance	$f = 1\text{ MHz}; V_R = 0\text{ V}$	-	2.9	3.5	pF
r_{dyn}	dynamic resistance	$I_R = 10\text{ A}$	[1]	0.8	-	Ω

[1] Non-repetitive current pulse, Transmission Line Pulse (TLP) $t_p = 100\text{ ns}$; square pulse; ANS/ESD STM5.5.1-2008.

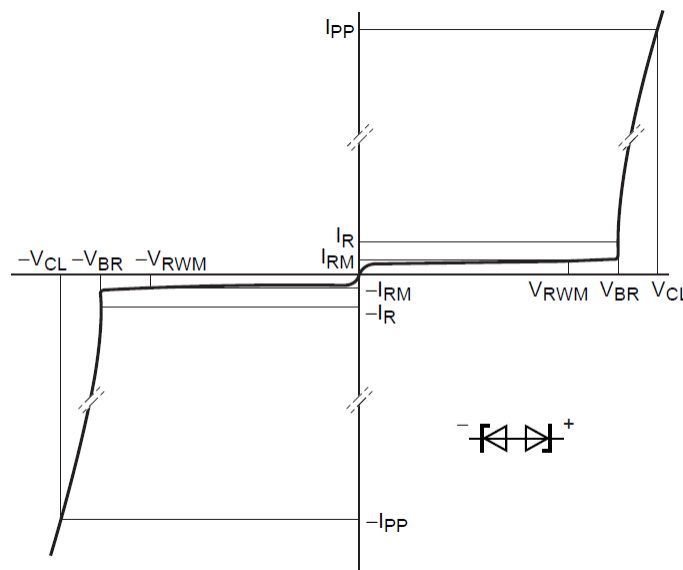


Figure 21. I-V Characteristics for a Bidirectional ESD Protection Diode

This TVS device is represented by a Zener diode model. The worst-case breakdown voltage of $V_{BR} = V_{TVS,t1,max} = 9.5\text{ V}$ represents the breakdown voltage of the zener diode and the dynamic on-resistance of $r_{dyn} = R_{TVS,on,max} = 0.8\text{ }\Omega + 20\% = 1\text{ }\Omega$ represents the series resistance (that is in series with the zener diode) (see Figure 22).

4.3 Modeling MSP430 I/O Pin

Example parameters of a specific MSP430 I/O pin that are required for SEED based simulations are listed below:

- IC-pin ESD minimum turn-on voltage (after ESD protection is triggered) = $V_{IC,t1,min} = 2.6\text{ V}$
- IC-pin ESD protection maximum acceptable current = $I_{IC,max} = 1.47\text{ A}$
- IC-pin ESD protection minimum on-resistance = $R_{IC,on,min} = 1.15\text{ }\Omega$
- IC-pin ESD protection maximum stress duration of equivalent TLP stress = $t_{Dmax} = 100\text{ ns}$

This MSP430 IC pin is also represented by a zener string model. The minimum turn-on voltage $V_{IC,t1,min} = 2.6\text{ V}$ represents the zener breakdown voltage, and the minimum on-resistance $R_{IC,on,min} = 1.15\text{ }\Omega$ represents the series resistance (that is, in series with the zener diode) (see Figure 22).

4.4 Isolated Impedance Calculation

Figure 22 shows the SEED method simulation of the IEC protection using SEED parameters to model the TVS device and the MSP430 I/O pin as discussed in previous sections.

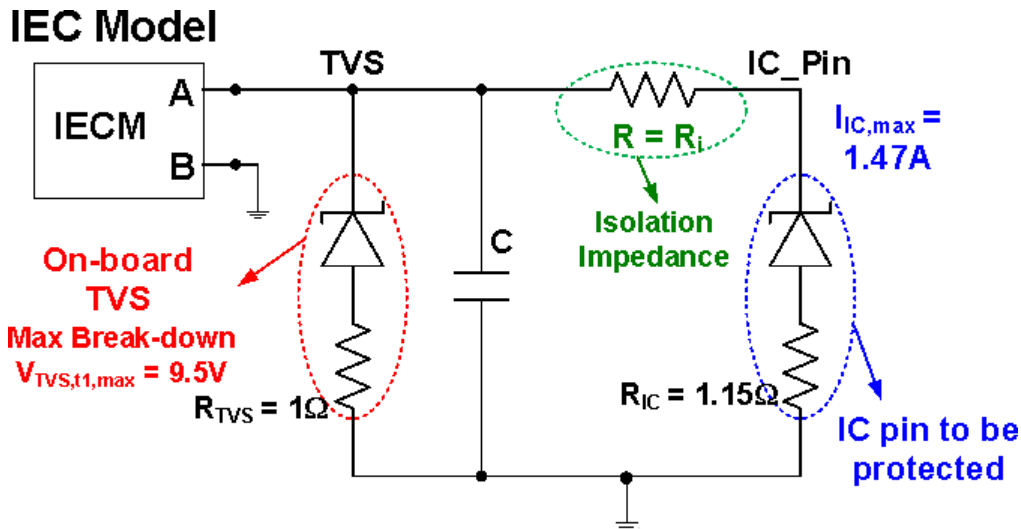


Figure 22. SEED Method Simulation Schematic

Figure 22 shows that the IEC ESD current pulse is first bypassed to GND by the TVS device (primary clamp) and the decoupling capacitor; thus, limiting the induced voltage of the IEC stress pulse. The TVS max diode breakdown voltage plus the dynamic voltage across the TVS (based on the on-resistance and current through the TVS) represents the voltage of the residual pulse that is presented at the isolation impedance. Using a decoupling capacitor in parallel to the TVS model limits the voltage due to the initial fast transient current peak of the IEC pulse at the TVS node. Therefore, for all further calculations, the peak IEC current of the slow discharge curve (which is approximately 18 A) is used. With max IEC pulse current ($I_{IEC,max}$) approximately 18 A and TVS on-resistance ($R_{TVS,on,max}$) approximately 1 Ω , the maximum voltage of the residual pulse presented at the isolated impedance is calculated as:

$$\begin{aligned} V_{TVS,max} &= V_{TVS,t1,max} + (I_{IEC,max} \times R_{TVS,on,max}) \\ V_{TVS,max} &= 9.5 \text{ V} + (18 \text{ A} \times 1 \Omega) \\ V_{TVS,max} &\approx 27.5 \text{ V} \end{aligned}$$

In this case, the isolation impedance is represented by a resistor between the primary and secondary clamps. The value of this resistor is calculated based on the max voltage drop across the resistor required such that the worst-case ESD current and voltage presented at the IC pin is not violated by the residual ESD stress

Given the MSP430 I/O pin on-chip ESD protection turn-on voltage (when ESD protection is triggered) of $V_{IC,t1,min} = 2.6 \text{ V}$, minimum on-resistance value of $R_{IC,on,min} = 1.15 \Omega$, and the maximum acceptable current of $I_{IC,max} = 1.47 \text{ A}$, the maximum acceptable voltage that can be presented to the IC pin is calculated as:

$$\begin{aligned} V_{IC,max} &= V_{IC,t1,min} + (I_{IC,max} \times R_{IC,on,min}) \\ V_{IC,max} &= 2.6 \text{ V} + (1.47 \text{ A} \times 1.15 \Omega) \\ V_{IC,max} &\approx 4.3 \text{ V} \end{aligned}$$

As a result, the minimum isolation or decoupling resistance value is calculated as:

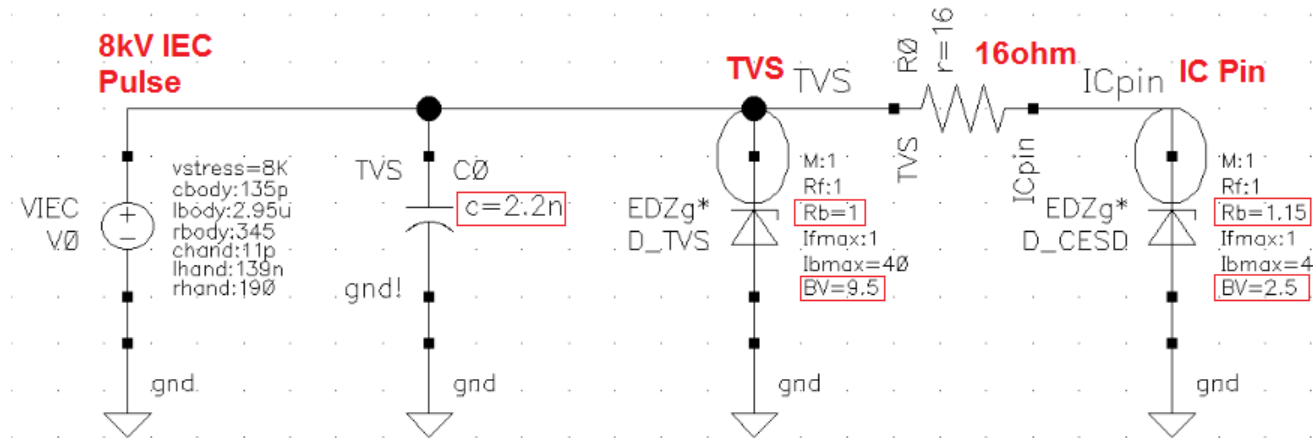
$$\begin{aligned} R_{i,min} &= \frac{V_{TVS,max} - V_{IC,max}}{I_{IC,max}} \\ R_{i,min} &= \frac{27.5 \text{ V} - 4.3 \text{ V}}{1.47 \text{ A}} \\ R_{i,min} &\approx 16 \Omega \end{aligned}$$

4.5 SPICE Simulation – SEED Method

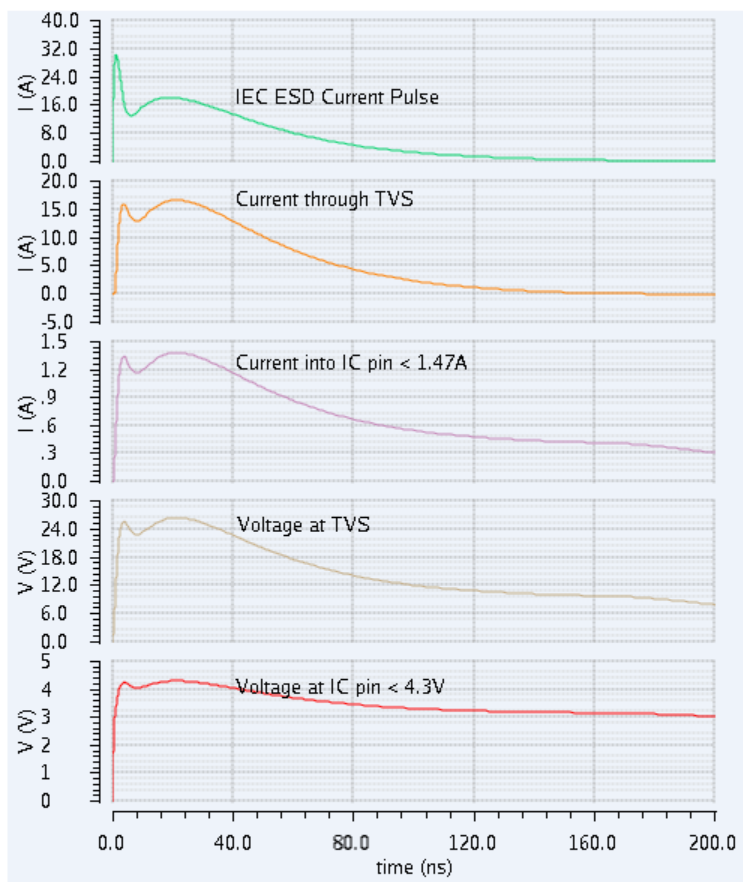
Figure 23(a) shows the SPICE simulation schematic of the IEC Protection design using the SEED methodology. It consists of the following blocks:

- IEC ESD pulse generator as shown in Figure 20. An 8-kV IEC pulse with initial transient peak of approximately 30 A and slow discharge curve with peak current of approximately 18 A is generated.
- TVS diode model with maximum breakdown voltage of 9.5 V and dynamic on-resistance of 1 Ω .
- Minimum decoupling capacitor with a capacitance value of 2.2 nF (in parallel to the TVS model) used to limit the voltage induced by the initial fast transient current spike.
- Decoupling resistor of 16 Ω between the TVS device and device interface pin models.
- MSP430 device interface pin model with minimum turn-on voltage of 2.6 V and minimum on-resistance of 1.15 Ω .

The SPICE simulation waveforms (both the current and voltage curves) at the TVS and IC pin nodes are as shown in Figure 23(b). Simulation waveforms show the peak current and voltage values of $I_{IEC,max}$ approximately 18 A and $V_{TVS,max}$ approximately 26.5 V at the TVS node respectively, and less than $I_{IC,max}$ of 1.47 A and $V_{IC,max}$ of 4.3 V at the IC pin node respectively. These results match nicely with the results of the calculation in Section 4.4.



(a)



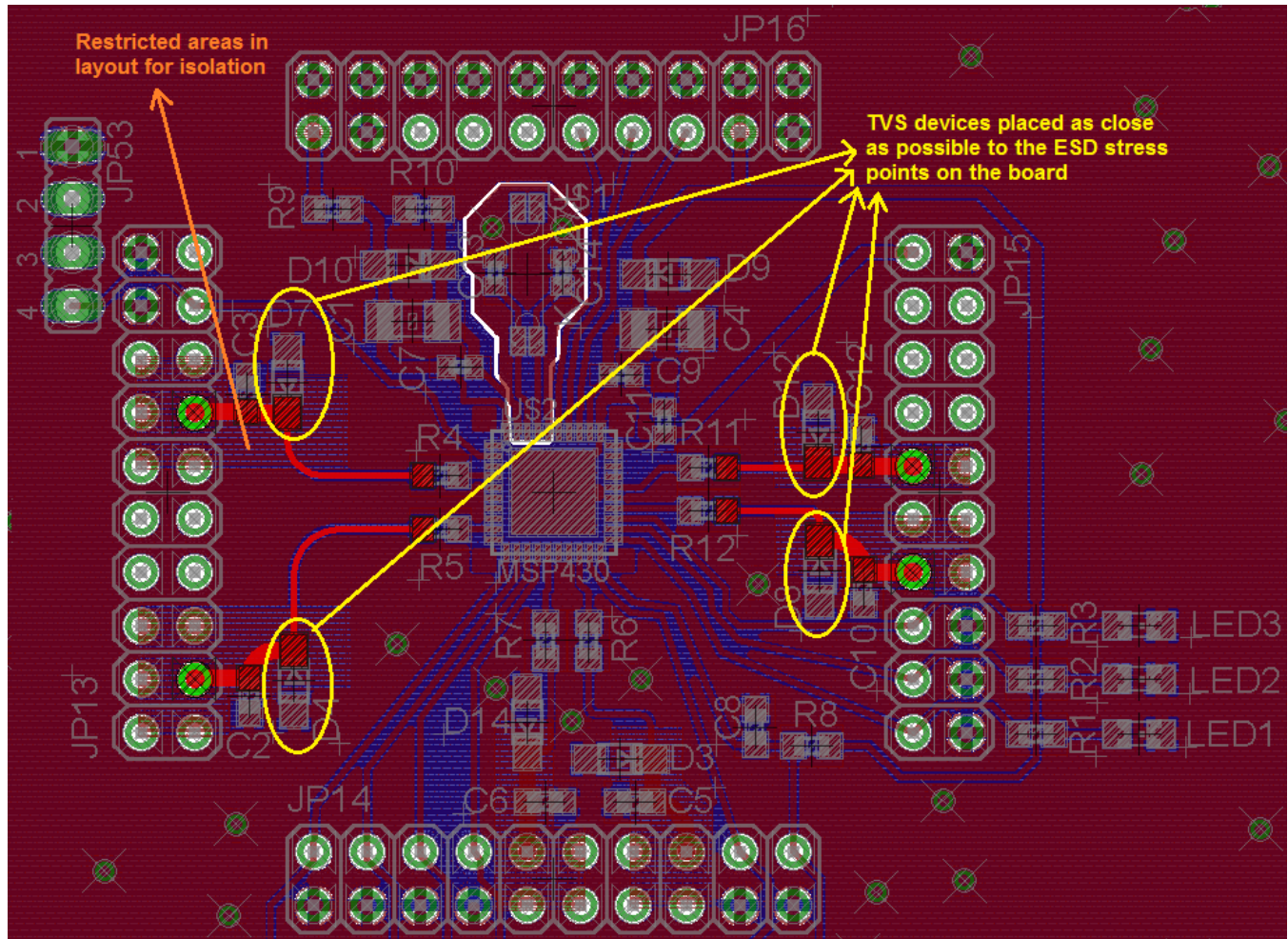
(b)

- (a): SEED schematic
- (b): Current and Voltage waveforms of the ESD stress pulse as seen at TVS and IC pin nodes

Figure 23. SEED Schematic and Simulation Results

4.6 Board-Level Verification

The IEC protection design designed using SEED methodology was implemented on a test board to verify the simulation results. Figure 24 shows the board layout of the test board with the standard TVS component (bidirectional ESD protection diode) and an MSP430 device. Four TVS devices are connected via decoupling resistors to four MSP430 I/O interface pins. The TVS components are placed close to the ESD stress points of the board. Decoupling resistors of approximately $18\ \Omega$ are added between each TVS device and the corresponding MSP430 IC pin being tested.



NOTE: With primary clamps (on-board TVS) and isolation impedance applied to MSP430 I/O pins.

Figure 24. MSP430-Based Test Board Layout

NOTE: The test board layout includes footprints for capacitors that are in parallel with the respective TVS components. These capacitors are useful to limit the voltage caused by the initial fast transient current spike of the IEC pulse. These capacitors were however not populated during verification testing in this case.

The system-level ESD tests applied ESD strikes (direct contact discharge) at the pins on pin headers JP13 and JP15 to which the TVS devices are connected. The summary of the test verification results (tested on three test boards) is:

- No device latch-up observed for up to ± 8 -kV IEC pulses
- No device reset observed for up to ± 2 kV.

5 System-Level ESD Protection – Real World Example 2

Figure 25 shows two MSP430-based real-time clock (RTC) boards.

The MSP430-based RTC Rev A board on the left follows poor layout techniques (no GND plane, traces beneath the 32-kHz crystal) and was known to cause system-level ESD issues where in, the MSP430 on the board consistently reset and sometimes latched when ESD pulses of 1.5 kV and 3.0 kV were applied to the top pins of the LCD.

To increase the system-level ESD robustness, the RTC Rev B board was designed (see board on right) following good layout techniques (extensive ground plane compared to Rev A) and with resistor arrays in series on the LCD signal lines (circled in red). The series resistors limit the ESD voltage reaching the device via the LCD signal, thus reducing the risk of system-level ESD failures.

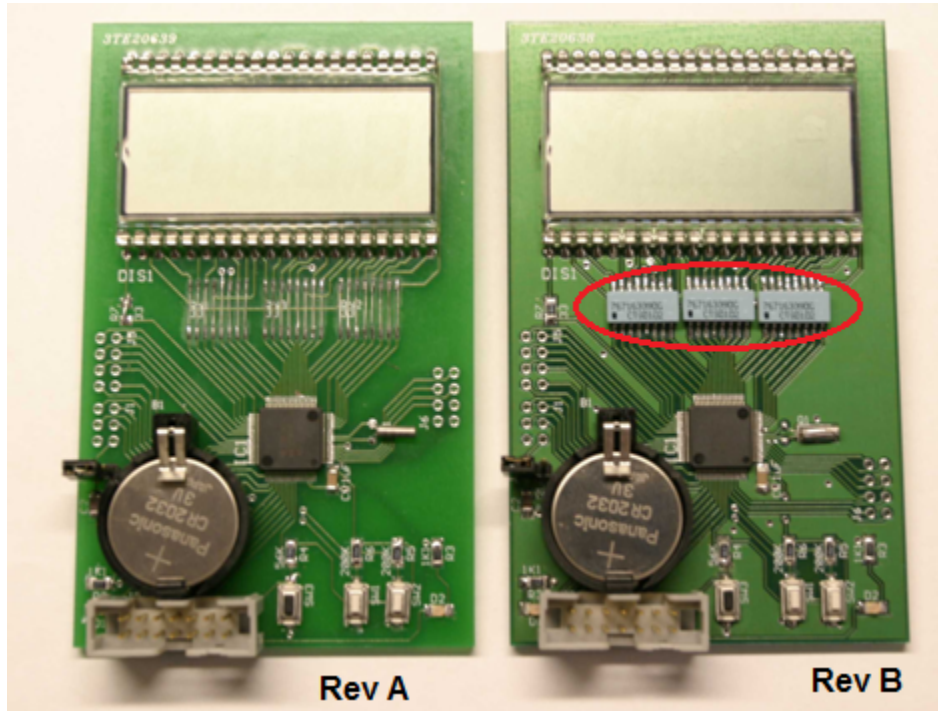


Figure 25. MSP430-Based Real-Time Clock Test Boards

For system-level ESD tests, the Keytek Minizap ESD simulator was used to apply high voltage ESD strikes to the top pins of the LCD via indirect discharge; thus simulating electrostatic discharge between human and a piece of equipment. Table 3 lists the test recordings with the Rev A and Rev B boards, with and without the series resistors on the LCD signal traces.

Table 3. System-Level ESD Performance - Real World Example 2 Results

	Rev A Board (No Ground Plane)	Rev B Board (With Ground Plane)		
		0 Ω	39 Ω	1 kΩ
Series Resistance	0 Ω	0 Ω	39 Ω	1 kΩ
Consistent Device Reset	1.5 kV	2.5 kV	2.5 kV	3.5 kV
Device Latch-Up	3.0 kV	3.0 kV	3.0 kV	>12 kV

It is clear from the results in Table 3 that the ESD robustness of the system improves by following good layout guidelines and by including additional protection circuitry like external series resistors on specific signals that couple the external ESD energy into the system or device. In particular, increasing the value of the series resistor on the Rev B board largely improved the ESD robustness; that is, units passed system-level ESD tests without device latch-up up to 12 kV.

NOTE: A crystal clock failure was reported on Rev A board due to the poor layout techniques. On the Rev A board, it can be noticed that the digital signal traces are running underneath the 32-kHz crystal on the PCB. Toggling these digital signals cause the crystal clock generated by the MSP430 on-chip oscillator to fail. This failure was not seen on the Rev B due to good layout techniques (that is, no traces underneath the crystal layout). For more information regarding crystal layout considerations, see the application report *MSP430 32-kHz Crystal Oscillator* [11].

6 Summary

Component-level ESD ratings (HBM and CDM) do not correlate with system-level ESD ratings (IEC). The component-level ratings address component or IC handling in ESD-protected areas (EPA) such as manufacturing and assembly environments. Increasing the component-level ESD rating to protect the device against system-level ESD pulses leads to increased IC area and reduced functional performance (for example, increased leakage current or reduced switching speed) and can be uneconomical, especially when compared to adding external on-board ESD protection for system-level ESD protection. And, in most of the cases, even with increased IC-level ESD rating, complete system level ESD robustness is still not achieved. On the contrary, with improvements in manufacturing ESD controls, the Industry Council for ESD Target Levels and JEDEC has recommended lowering the component-level ESD ratings that are required for a safe handling of ICs.

Designing an ESD robust system needs a holistic approach. It requires the board designers and OEMs to (1) understand and evaluate ESD effects in their system early in design; (2) follow ESD-immune design guidelines in the design and development from the beginning; and (3) perform system-level ESD testing (per IEC 61000-4-2) at various development stages to help identify and fix ESD-related weaknesses in the design.

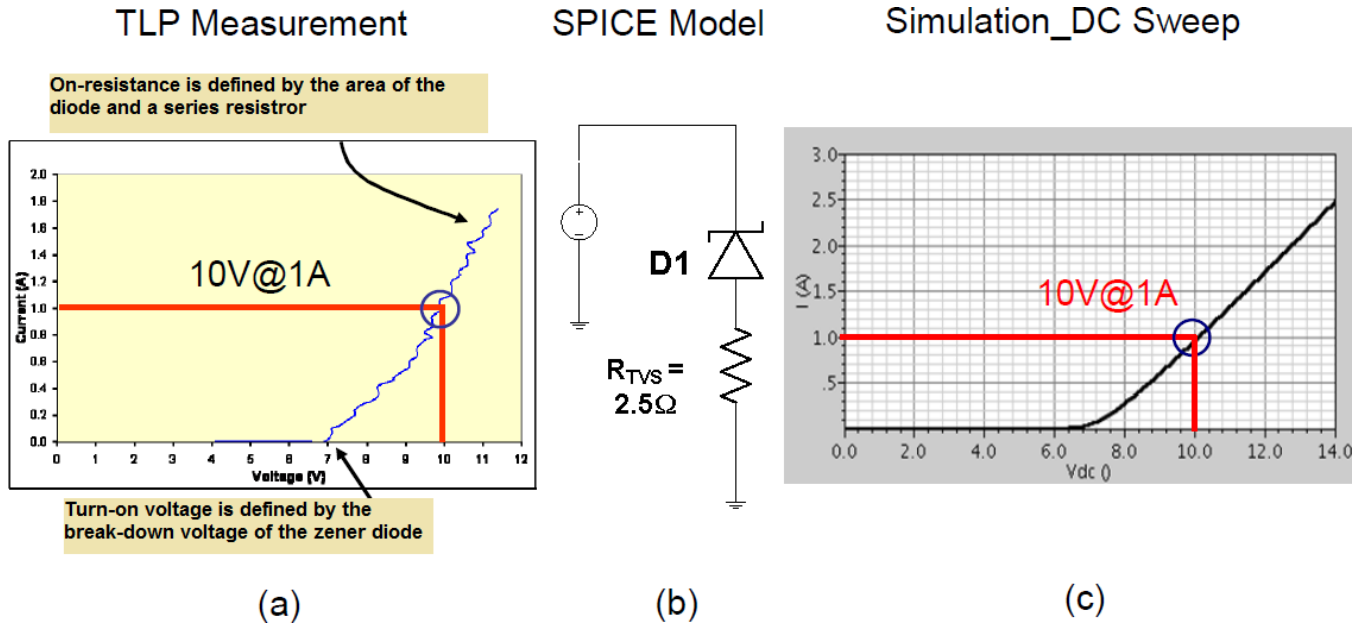
7 References

1. International Electrotechnical Commission, IEC 61000-4-2, *Electromagnetic capability (EMC) – Part 4-2: Testing and measurement techniques – Electrostatic discharge immunity test*, Ed. 2.0
2. JEDEC Publication (White Paper 3) JEP161: *System-level ESD Part I: Common Misconceptions and Recommended Basic Approaches*
3. ESDA/JEDEC Joint Standard for *Electrostatic Discharge Sensitivity Testing – Human Body Model –Component Level*, ANSI ESDA/JEDEC JS-001-2011
4. JESD22-C101 *Field-Induced Charged-Device Model Test Method for Electrostatic Discharge Withstand Thresholds of Microelectronic Components*
5. Texas Instruments Inc., ESD and EMI Device Protection Product Portfolio, www.ti.com/emi
6. ISO Standard 10605 *Road vehicles – Test methods for electrical disturbances from electrostatic discharge*, International Organization for Standardization, 2008
7. S. Marum, C. Duvvury, J. Park, A. Chadwick, A. Jahanzeb; *Protection Circuits from the Transient Voltage Suppressor's Residual Pulse During IEC 61000-4-2 Stress*, Proc. EOS/ESD Symposium 2009 (2009)
8. Lifang Lou, Charvaka Duvvury, Agha Jahanzeb, Jae Park; *SPICE Simulation Methodology for System-level ESD Design*, Proc EOS/ESD Symposium 2010 (2010)
9. Industry Council on ESD Target Levels, *White Paper 1: A Case for Lowering Component Level HBM/MM ESD Specifications and Requirements*, August 2007, at www.esda.org or JEDEC publication JEP155, *Recommended ESD Target Levels for HBM/MM Qualification*, www.jedec.org
10. Industry Council on ESD Target Levels, *White Paper 2: A Case for Lowering Component Level CDM ESD Specifications and Requirements*, Revision 2, April 2010, at www.esda.org or JEDEC publication JEP157, 'Recommended ESD-CDM Target Levels', www.jedec.org
11. *MSP430 32-kHz Crystal Oscillator* ([SLAA322](http://www.ti.com/lit/SLAA322))
12. *High-Speed Layout Guidelines* ([SCAA082](http://www.ti.com/lit/SCAA082))
13. ESD Association Standard for the development of an Electrostatic Discharge Control Program for Protection of Electrical and Electronic Parts, Assemblies and Equipment (Excluding Electrically Initiated Explosive Devices), ANSI/ESD S20.20-2007
14. International Electrotechnical Commission, IEC 61340 standards family, Electrostatics - Part 2-1 to 5-3
15. Industry Council on ESD Target Levels, <http://www.esdindustrycouncil.org>

Appendix A Modeling Using TLP Parameters

A.1 Modeling TVS Device Using TLP Parameters [8]

This example case discusses the modeling of a TVS device that acts as a Zener diode, turning on at approximately 7 V. Its 100-ns TLP I-V characteristic is shown in Figure 26(a). The SPICE model is generated based on I-V data using a zener diode model, as shown in Figure 26(b). The trigger voltage is represented by the zener breakdown voltage and the on-resistance by a fitted series resistor. The simulation in Figure 26(b) is tuned to match the quasi-static TLP characteristic in Figure 26(a) as confirmed by the DC sweep in Figure 26(c).



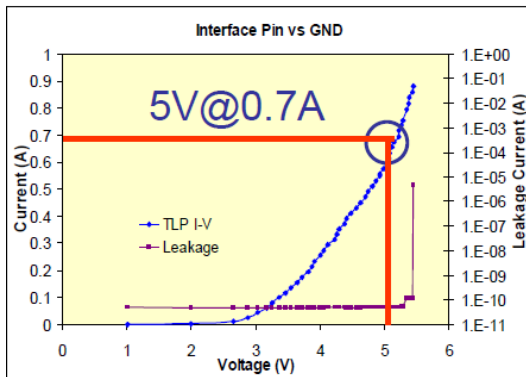
- (a): Quasi-static 100-ns TLP I-V curve
- (b): The respective SPICE model
- (c): The simulation results of the TVS [8]

Figure 26. Modeling TVS Device Using TLP Parameters

A.2 Modeling IC Interface Pin to be Protected Using TLP Parameters [8]

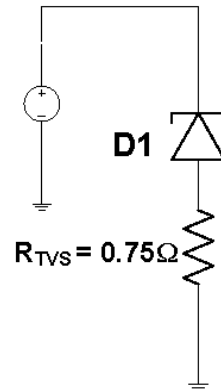
This example case discusses the modeling of an IC interface pin with the 100-ns TLP I-V characteristic as shown in Figure 27(a). The SPICE model is generated based on the quasi-static I-V characteristic using a zener diode, as shown in Figure 27(b).

TLP Measurement



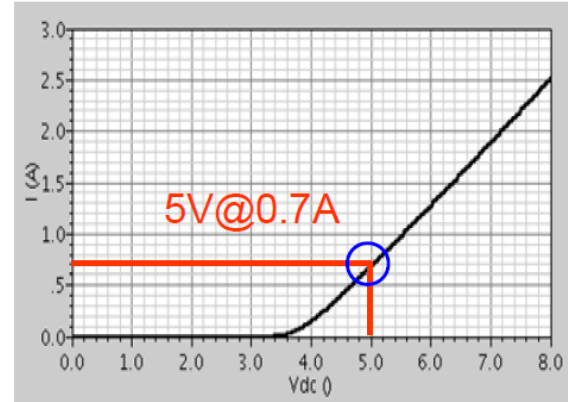
(a)

SPICE Model



(b)

Simulation_DC Sweep



(c)

- (a): Quasi-static 100-ns TLP I-V curve
- (b): The respective SPICE model
- (c): The simulation results of an example IC interface pin [8]

Figure 27. Modeling IC Interface Pin Using TLP Parameters

NOTE: The TLP data used in this example is not related to MSP430 devices and are used only to show the modeling process.

From Figure 27(a) and Figure 27(c), it can be seen that the actual turn-on point as per the TLP I-V curve and the TLP model simulation is at 2.6 V and 3.4 V, respectively. However, the model simulation matches the TLP data in the conduction region which is more relevant. Therefore, when tweaking the clamping device model to match the TLP data, the conduction region is more important than the turn-on point if a compromise must be made.

IMPORTANT NOTICE

Texas Instruments Incorporated and its subsidiaries (TI) reserve the right to make corrections, modifications, enhancements, improvements, and other changes to its products and services at any time and to discontinue any product or service without notice. Customers should obtain the latest relevant information before placing orders and should verify that such information is current and complete. All products are sold subject to TI's terms and conditions of sale supplied at the time of order acknowledgment.

TI warrants performance of its hardware products to the specifications applicable at the time of sale in accordance with TI's standard warranty. Testing and other quality control techniques are used to the extent TI deems necessary to support this warranty. Except where mandated by government requirements, testing of all parameters of each product is not necessarily performed.

TI assumes no liability for applications assistance or customer product design. Customers are responsible for their products and applications using TI components. To minimize the risks associated with customer products and applications, customers should provide adequate design and operating safeguards.

TI does not warrant or represent that any license, either express or implied, is granted under any TI patent right, copyright, mask work right, or other TI intellectual property right relating to any combination, machine, or process in which TI products or services are used. Information published by TI regarding third-party products or services does not constitute a license from TI to use such products or services or a warranty or endorsement thereof. Use of such information may require a license from a third party under the patents or other intellectual property of the third party, or a license from TI under the patents or other intellectual property of TI.

Reproduction of TI information in TI data books or data sheets is permissible only if reproduction is without alteration and is accompanied by all associated warranties, conditions, limitations, and notices. Reproduction of this information with alteration is an unfair and deceptive business practice. TI is not responsible or liable for such altered documentation. Information of third parties may be subject to additional restrictions.

Resale of TI products or services with statements different from or beyond the parameters stated by TI for that product or service voids all express and any implied warranties for the associated TI product or service and is an unfair and deceptive business practice. TI is not responsible or liable for any such statements.

TI products are not authorized for use in safety-critical applications (such as life support) where a failure of the TI product would reasonably be expected to cause severe personal injury or death, unless officers of the parties have executed an agreement specifically governing such use. Buyers represent that they have all necessary expertise in the safety and regulatory ramifications of their applications, and acknowledge and agree that they are solely responsible for all legal, regulatory and safety-related requirements concerning their products and any use of TI products in such safety-critical applications, notwithstanding any applications-related information or support that may be provided by TI. Further, Buyers must fully indemnify TI and its representatives against any damages arising out of the use of TI products in such safety-critical applications.

TI products are neither designed nor intended for use in military/aerospace applications or environments unless the TI products are specifically designated by TI as military-grade or "enhanced plastic." Only products designated by TI as military-grade meet military specifications. Buyers acknowledge and agree that any such use of TI products which TI has not designated as military-grade is solely at the Buyer's risk, and that they are solely responsible for compliance with all legal and regulatory requirements in connection with such use.

TI products are neither designed nor intended for use in automotive applications or environments unless the specific TI products are designated by TI as compliant with ISO/TS 16949 requirements. Buyers acknowledge and agree that, if they use any non-designated products in automotive applications, TI will not be responsible for any failure to meet such requirements.

Following are URLs where you can obtain information on other Texas Instruments products and application solutions:

Products

Audio	www.ti.com/audio
Amplifiers	amplifier.ti.com
Data Converters	dataconverter.ti.com
DLP® Products	www.dlp.com
DSP	dsp.ti.com
Clocks and Timers	www.ti.com/clocks
Interface	interface.ti.com
Logic	logic.ti.com
Power Mgmt	power.ti.com
Microcontrollers	microcontroller.ti.com
RFID	www.ti-rfid.com
OMAP Mobile Processors	www.ti.com/omap
Wireless Connectivity	www.ti.com/wirelessconnectivity

Applications

Automotive and Transportation	www.ti.com/automotive
Communications and Telecom	www.ti.com/communications
Computers and Peripherals	www.ti.com/computers
Consumer Electronics	www.ti.com/consumer-apps
Energy and Lighting	www.ti.com/energy
Industrial	www.ti.com/industrial
Medical	www.ti.com/medical
Security	www.ti.com/security
Space, Avionics and Defense	www.ti.com/space-avionics-defense
Video and Imaging	www.ti.com/video

TI E2E Community Home Page

e2e.ti.com

Mailing Address: Texas Instruments, Post Office Box 655303, Dallas, Texas 75265
Copyright © 2012, Texas Instruments Incorporated