

# Interfacing op amps to high-speed DACs, Part 1: Current-sinking DACs

By Jim Karki

Member, Technical Staff, High-Performance Analog

## Introduction

Digital-to-analog converters (DACs) come in many bit resolutions and sampling speeds. Outputs from lower-speed DACs are often single-ended and have either a voltage or a current output. Most high-speed DACs are designed with complementary outputs that either source or sink current. This article, Part 1 of a three-part series, discusses the interface between a current-sinking DAC and an op amp. Part 2, which will appear in a future issue of the *Analog Applications Journal*, will discuss the interface between a current-sourcing DAC and an op amp. Part 3, also in a future issue of the *Analog Applications Journal*, will provide a simplified approach to the interface analogy presented in Part 2.

High-speed DACs are used in end-equipment applications like communications, test equipment, medical applications, industrial applications, and many more where signal generation is required. Each of these applications has its own specific requirements for signal characteristics and performance. This article focuses on end equipment that requires DC coupling, like signal generators with frequency bandwidths of up to 100 MHz and a single-ended output. In these cases, high-speed op amps can provide a good solution for converting the complementary-current output from a high-speed DAC to a voltage that can drive the signal output.

## Overview of complementary-current-steering DAC

A simplified block diagram of a complementary-current-steering DAC is shown in Figure 1. The digital input is decoded for the switch drivers that switch, or steer, the appropriate current source(s) in the current-source array to the outputs,  $I_{OUT1}$  and  $I_{OUT2}$ .  $I_{OUT1}$  and  $I_{OUT2}$  are complementary, which means that if current flows out of one it is subtracted from the other, and vice versa, keeping the total current constant. For example, if full scale is 20 mA, the minimum code input or zero-scale input may provide

Figure 1. Simplified block diagram of current-steering DAC

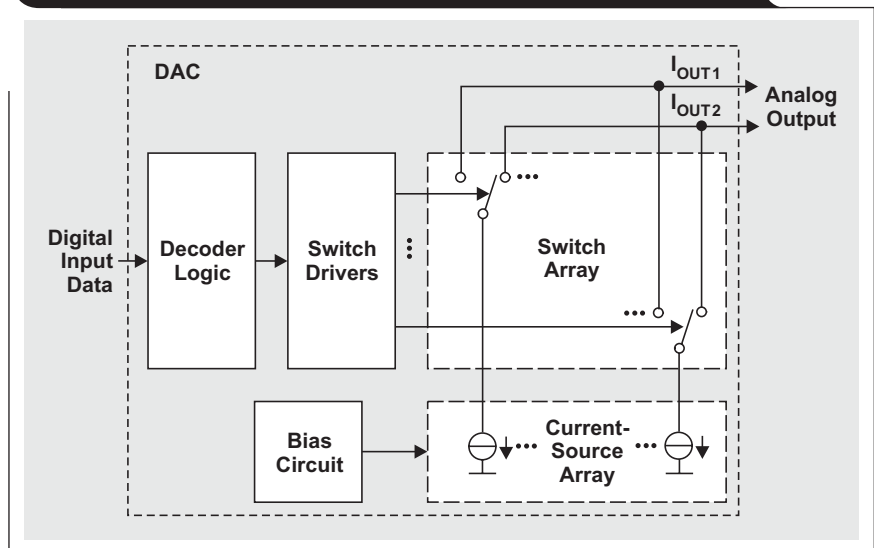

0 mA at  $I_{OUT1}$  and 20 mA at  $I_{OUT2}$ . At midscale, each output provides 10 mA; and at maximum or full scale,  $I_{OUT1} = 20$  mA and  $I_{OUT2} = 0$  mA. This example is illustrated in Table 1. It is important to note that the midscale input, with each output at 10 mA, will be used to set the output common-mode condition for the design.

The current-source array is constructed with either n-type or p-type transistors. The word “source” is used generically to refer to the transistor circuit structure, which may either source or sink current. This article considers the interface between a current-sinking DAC and an op amp in the case where the source array is constructed with n-type transistors.

Table 1. Example of  $I_{OUT1}$  and  $I_{OUT2}$  currents for 20-mA full scale

INPUT	$I_{OUT1}$ (mA)	$I_{OUT2}$ (mA)
Maximum Scale	20	0
Midscale	10	10
Zero Scale	0	20

Figure 2. Simplified NMOS and NPN current sinks

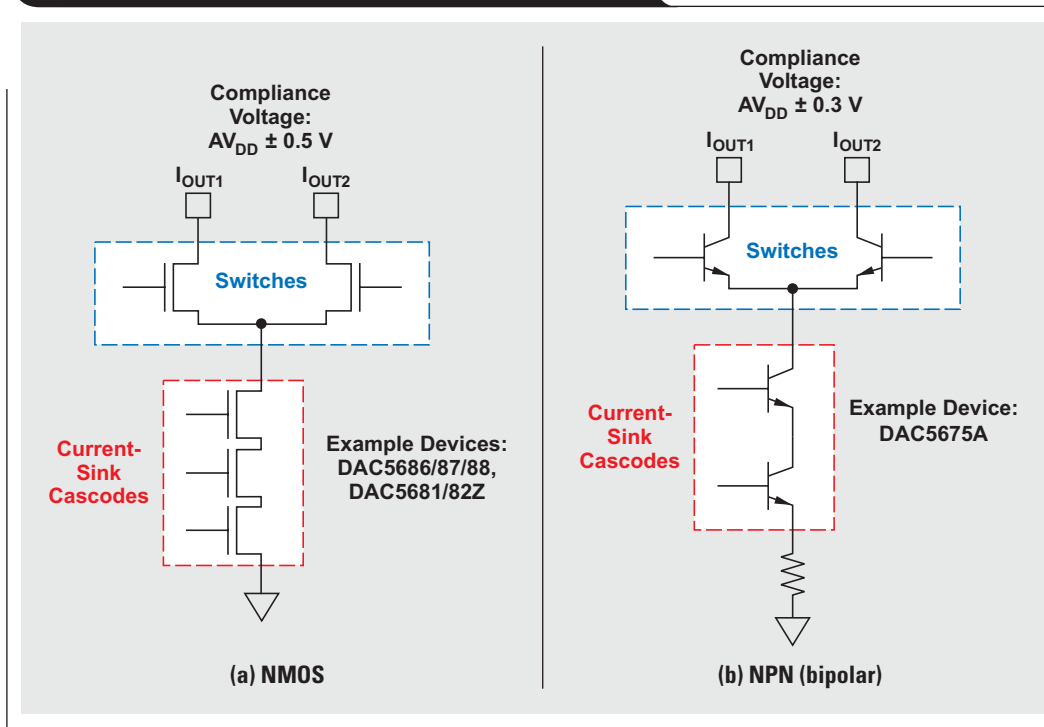

## Architecture and compliance voltage of current-sinking DACs

Figure 2 shows simplified examples of NMOS and NPN current sinks and lists a few devices that use them. The compliance voltage shown for each group of devices is the voltage range at the DAC outputs within which a device will perform as specified. Lower voltages tend to shut down the outputs, and higher voltages have the potential to cause breakdown. Both of these should be avoided to provide the best performance and long-term reliability.

Generally the output is terminated via some impedance to a positive power supply. This impedance supplies a current path needed for the sink array, and the voltage drop across the same impedance can be used as a voltage output. The impedance can be constructed in various ways; it can be a simple resistor divider, a transformer-coupled impedance, or a combination of passive components and an active circuit. This article focuses on the latter option, with an op amp as the active circuit.

### Op amp interface

The proposed op amp interface is shown in Figure 3. This circuit will provide biasing of the DAC outputs, convert the DAC currents to voltages, and provide a single-ended output voltage via the op amp. The op amp is the active

Figure 3. Proposed circuit for an op amp interface

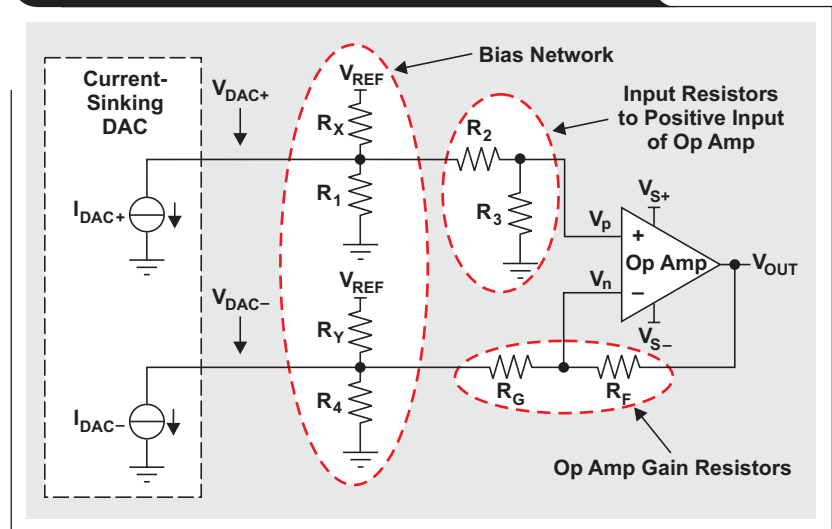

amplifier element for the circuit and uses  $R_2$ ,  $R_3$ ,  $R_G$ , and  $R_F$  to make a difference amplifier.

- $I_{DAC+}$  and  $I_{DAC-}$  are the current outputs from the DAC.
- $R_2$  and  $R_3$  are input resistors to the positive input of the op amp.
- $R_G$  and  $R_F$  are the main gain-setting resistors for the op amp.
- $R_X$ ,  $R_1$ ,  $R_Y$ , and  $R_4$  provide bias and impedance termination for the DAC outputs.

- $V_{DAC+}$  and  $V_{DAC-}$  are the voltages at the outputs of the DAC.
- $V_p$  and  $V_n$  are the input terminals of the op amp.
- $V_{S+}$  and  $V_{S-}$  are the power supplies to the op amp.

Proper component selection will provide the impedance required to maintain voltage compliance with maximum amplitude and balance for the best performance.

Typically, harmonic distortion in an op amp is dominated (at least at lower frequencies) by the second-order harmonics. Balanced inputs to the difference-amplifier circuit will help suppress second-order harmonics and provide for the best performance, but little impact is expected on third-order harmonics if the inputs are not balanced.

For analysis, it is easiest to break the circuit into positive and negative halves and examine each separately. It will also be assumed that the op amp is ideal.

**Analysis of positive side**

The positive half of the circuit is shown in Figure 4. To start the analysis, Kirchhoff’s current law can be used to write a node equation at  $V_{DAC+}$ :

$$I_{DAC+} + \frac{V_{DAC+} - V_{REF}}{R_X} + \frac{V_{DAC+}}{R_1} + \frac{V_{DAC+}}{R_2 + R_3} = 0 \quad (1)$$

The input impedance can be expressed as

$$Z_{DAC+} = R_X \parallel R_1 \parallel (R_2 + R_3). \quad (2)$$

Equations 1 and 2 are simultaneous equations with many variables, and designers must choose or identify values based on other design criteria in order to solve them. The following assumptions are made for this article:

1. The DAC output current,  $I_{DAC+}$ , and the voltage swing,  $V_{DAC+}$ , are defined by the designer, which sets a target value for  $Z_{DAC+}$ .
2. An existing circuit voltage or other known voltage is used for  $V_{REF}$ .
3. In a difference amplifier,  $R_3/R_2$  needs to equal  $R_F/R_G$  to balance the gain of the amplifier.\*
4. The equations will be solved for the condition where the DAC current on the positive side is zero:  $I_{DAC+} = 0$  mA. This in turn sets the DAC voltage on the positive side to its maximum value,  $V_{DAC+} = V_{DAC+}(\text{max})$ .

With these constraints, the designer can apply algebra and simultaneous-equation techniques to Equations 1 and 2 to solve for  $1/R_1$ :

$$\frac{1}{R_1} = \frac{1}{Z_{DAC+} \left( 1 + \frac{1}{\frac{V_{REF}}{V_{DAC+}(\text{max})} - 1} \right)} - \frac{1}{R_2 + R_3} \quad (3)$$

\*Note that in a voltage-feedback op amp, it is desirable to make the impedance at  $V_p$  equal to that at  $V_n$  in order to cancel voltage offset caused by the input bias current. In a current-feedback op amp, the input bias currents are not correlated; so it is acceptable not to balance these impedances, but it may be desirable to minimize them.

**Figure 4. Positive side of analysis circuit**

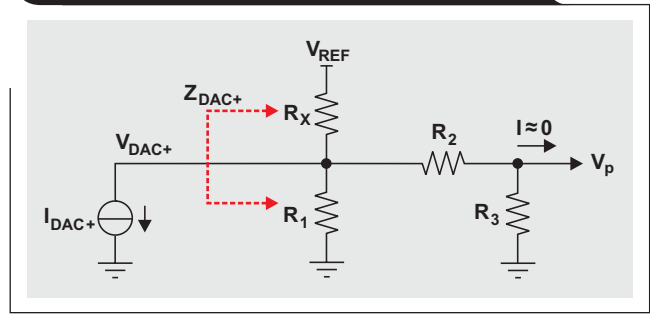

The known value for  $R_1$  can be substituted into Equation 2, which can then be rearranged to find  $1/R_X$ :

$$\frac{1}{R_X} = \frac{1}{Z_{DAC+}} - \frac{1}{R_1} - \frac{1}{R_2 + R_3} \quad (4)$$

**Analysis of negative side**

The negative half of the circuit is shown in Figure 5. Analysis of the negative side is complicated, because  $V_n$  is driven not only by the negative side of the DAC but also by the positive side via the op amp’s action. To start the analysis, Kirchhoff’s current law can be used to write a node equation at  $V_{DAC-}$ :

$$I_{DAC-} + \frac{V_{DAC-} - V_{REF}}{R_Y} + \frac{V_{DAC-}}{R_4} + \frac{V_{DAC-} - V_n}{R_G + R_3} = 0 \quad (5)$$

The input impedance can be expressed as

$$Z_{DAC-} = \frac{V_{DAC-}}{I_{DAC-}}. \quad (6)$$

With substitution and rearrangement, the designer can use

$$V_p = V_{DAC+} \times \frac{R_3}{R_2 + R_3}$$

and  $V_n = \alpha V_p$  to rewrite Equation 6 as

$$\frac{1}{Z_{DAC-}} = \frac{1}{Z_{DAC+} \times \alpha \left( \frac{R_3}{R_2 + R_3} \right)} \times \left( \frac{1}{R_Y} + \frac{1}{R_4} + \frac{1}{R_G} \right). \quad (7)$$

**Figure 5. Negative side of analysis circuit**

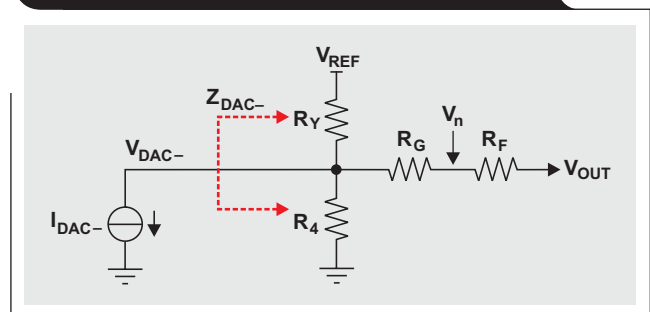

Using the same substitutions and general design constraints used on the positive side to drive values for  $Z_{\text{DAC-}}$ ,  $V_{\text{REF}}$ , and  $R_G$ , simultaneous-equation techniques can be applied to Equations 5 and 7 to solve for  $1/R_4$  (Equation 8). Note that the equations are solved for the condition where the DAC current on the negative side is zero:  $I_{\text{DAC-}} = 0$  mA. This sets the DAC voltage on the negative side to its maximum value,  $V_{\text{DAC-}} = V_{\text{DAC-(max)}}$ , and sets the DAC voltage on the positive side to its minimum value,  $V_{\text{DAC+}} = V_{\text{DAC+(min)}}$ .

$$\frac{1}{R_4} = \frac{1 - \frac{Z_{\text{DAC+}} \times \alpha \left( \frac{R_3}{R_2 + R_3} \right)}{R_G}}{Z_{\text{DAC-}}} + \frac{\left[ \frac{V_{\text{DAC+(min)}} \times \alpha \left( \frac{R_3}{R_2 + R_3} \right) - V_{\text{DAC-(max)}}}{V_{\text{REF}} - V_{\text{DAC-(max)}}} - 1 \right] \left( \frac{1}{R_G} \right)}{\frac{V_{\text{DAC-(max)}}}{V_{\text{REF}} - V_{\text{DAC-(max)}}} + 1} \quad (8)$$

The value of  $1/R_4$  can then be used to find  $1/R_Y$ :

$$\frac{1}{R_Y} = \frac{1 - \frac{Z_{\text{DAC+}} \times \alpha \left( \frac{R_3}{R_2 + R_3} \right)}{R_G}}{Z_{\text{DAC-}}} - \left( \frac{1}{R_4} + \frac{1}{R_G} \right) \quad (9)$$

Note that  $\alpha$ , the multiplication factor from  $V_p$  to  $V_n$ , in essence expresses the difference between the input pins. In a voltage-feedback amplifier,  $\alpha$  is set by the loop gain of the amplifier. In a current-feedback amplifier,  $\alpha$  is the gain of the input buffer between the inputs. All that aside,  $\alpha$  is typically close enough to 1 that it can simply be removed from the calculation.

### Calculating output voltage

Superposition can be used to write equations for the separate sources referred to  $V_{\text{OUT}}$ . Since the DAC only sinks current, which is by convention negative current flow, the output-voltage swing is the opposite of what might be expected. In other words, when the DAC is sinking current on the positive side, the output of the op amp tends to swing negative, and when the DAC is sinking current on the negative side, the output of the op amp tends to swing positive. This means that in the following equations,  $I_{\text{DAC+}}$  and  $I_{\text{DAC-}}$  are always negative or zero.

The output-referred DC bias from the positive side is

$$V_{\text{OUT-}V_{\text{p(DC)}}} = \left( 1 + \frac{R_F}{R_G + R_Y \parallel R_4} \right) \times \left[ V_{\text{REF}} \times \frac{R_1 R_3}{R_1 (R_2 + R_3) + R_X (R_1 + R_2 + R_3)} \right]$$

The output-referred DAC signal from the positive side is

$$V_{\text{OUT-}V_{\text{p(DAC)}}} = \left( 1 + \frac{R_F}{R_G + R_Y \parallel R_4} \right) \times \left[ I_{\text{DAC+}} \times \frac{R_X R_1 R_3}{R_X R_1 + (R_1 + R_X)(R_2 + R_3)} \right]$$

The output-referred DC bias from the negative side is

$$V_{\text{OUT-}V_{\text{n(DC)}}} = - \left( V_{\text{REF}} \times \frac{R_4}{R_Y + R_4} \times \frac{R_F}{R_G + R_Y \parallel R_4} \right)$$

The output-referred DAC signal from the negative side is

$$V_{\text{OUT-}V_{\text{n(DAC)}}} = - \left( I_{\text{DAC-}} \times \frac{R_Y R_4 R_F}{R_Y R_4 + R_G R_4 + R_Y R_G} \right)$$

Adding these four equations provides an expression for  $V_{\text{OUT}}$ :

$$V_{\text{OUT}} = V_{\text{OUT-}V_{\text{p(DC)}}} + V_{\text{OUT-}V_{\text{p(DAC)}}} + V_{\text{OUT-}V_{\text{n(DC)}}} + V_{\text{OUT-}V_{\text{n(DAC)}}} \quad (10)$$

If it is assumed that  $I_{\text{DAC}} = I_{\text{DAC+}} - I_{\text{DAC-}}$ ,  $Z = Z_{\text{DAC+}} = Z_{\text{DAC-}}$ , and  $R_F/R_G = R_3/R_2$ , the DC component of the DAC outputs will cancel and the AC-signal's gain equation from the DAC output current to the voltage output of the op amp can be simplified and written as

$$\frac{V_{\text{OUT}}}{I_{\text{DAC}}} = 2Z \times \frac{R_F}{R_G} \quad (11)$$

## Design example and simulation

For an example of how to proceed with the design, assume that one of the NMOS DACs noted earlier, with a compliance voltage of  $3.3 \pm 0.5$  V, is being used. Also assume that the full-scale output is set to 20 mA. To get a  $5\text{-}V_{PP}$ , DC-coupled single-ended output signal, the circuit shown in Figure 3 can be used. Since a  $\pm 5\text{-V}$  power supply is being used for the op amp, it is convenient to make  $V_{REF} = 5$  V. Given that  $I_{DAC\pm} = 20$  mA and  $V_{DAC\pm} = 1 V_{PP}$ , the target impedance,  $Z_{DAC\pm}$ , can be calculated to equal  $50 \Omega$ .

With the starting design constraints given earlier, the THS3095 current-feedback op amp is selected as the amplifier, where  $R_3 = R_F = 750 \Omega$ . The gain from  $V_{DAC\pm}$  to the output is given by the resistor ratios  $R_F/R_G = R_3/R_2$ , so  $R_G$  can be calculated as

$$R_G = R_2 = R_F \times \frac{V_{DAC\pm}}{V_{OUT}} = 750 \Omega \times \frac{2(1 \text{ V})}{5 \text{ V}} = 300 \Omega.$$

The nearest standard 1% value,  $301 \Omega$ , should be used.

Equations 3, 4, 8, and 9 can be used to find, respectively,  $R_1$ ,  $R_X$ ,  $R_4$ , and  $R_Y$ :

$$R_1 = \frac{1}{\frac{1}{Z_{DAC+} \left( 1 + \frac{1}{\frac{V_{REF}}{V_{DAC+(max)}} - 1} \right)} - \frac{1}{R_2 + R_3}} = \frac{1}{\frac{1}{50 \Omega \left( 1 + \frac{1}{\frac{5 \text{ V}}{3.8 \text{ V}} - 1} \right)} - \frac{1}{301 \Omega + 750 \Omega}} = 259.8 \Omega$$

$$R_X = \frac{1}{\frac{1}{Z_{DAC+}} - \frac{1}{R_1} - \frac{1}{R_2 + R_3}} = \frac{1}{\frac{1}{50 \Omega} - \frac{1}{259.8 \Omega} - \frac{1}{301 \Omega + 750 \Omega}} = 65.8 \Omega$$

$$R_4 = \frac{\frac{V_{DAC-(max)}}{V_{REF} - V_{DAC-(max)}} + 1}{1 - \frac{Z_{DAC+} \times \alpha \left( \frac{R_3}{R_2 + R_3} \right)}{R_G} + \left[ \frac{V_{DAC+(min)} \times \alpha \left( \frac{R_3}{R_2 + R_3} \right) - V_{DAC-(max)}}{V_{REF} - V_{DAC-(max)}} - 1 \right] \left( \frac{1}{R_G} \right)}$$

$$= \frac{\frac{3.8 \text{ V}}{5 \text{ V} - 3.8 \text{ V}} + 1}{1 - \frac{50 \Omega \times 1 \times \frac{750 \Omega}{301 \Omega + 750 \Omega}}{301 \Omega} + \left( \frac{2.8 \text{ V} \times 1 \times \frac{750 \Omega}{301 \Omega + 750 \Omega} - 3.8 \text{ V}}{5 \text{ V} - 3.8 \text{ V}} - 1 \right) \left( \frac{1}{301 \Omega} \right)} = 447.2 \Omega$$

$$R_Y = \frac{1}{\frac{Z_{DAC+} \times \alpha \left( \frac{R_3}{R_2 + R_3} \right)}{R_G} - \left( \frac{1}{R_4} + \frac{1}{R_G} \right)} = \frac{1}{1 - \frac{50 \Omega \times 1 \times \frac{750 \Omega}{301 \Omega + 750 \Omega}}{301 \Omega} - \left( \frac{1}{447.2 \Omega} + \frac{1}{301 \Omega} \right)} = 82.9 \Omega$$

Figure 6. Simulation of current-sinking DAC interfaced to op amp

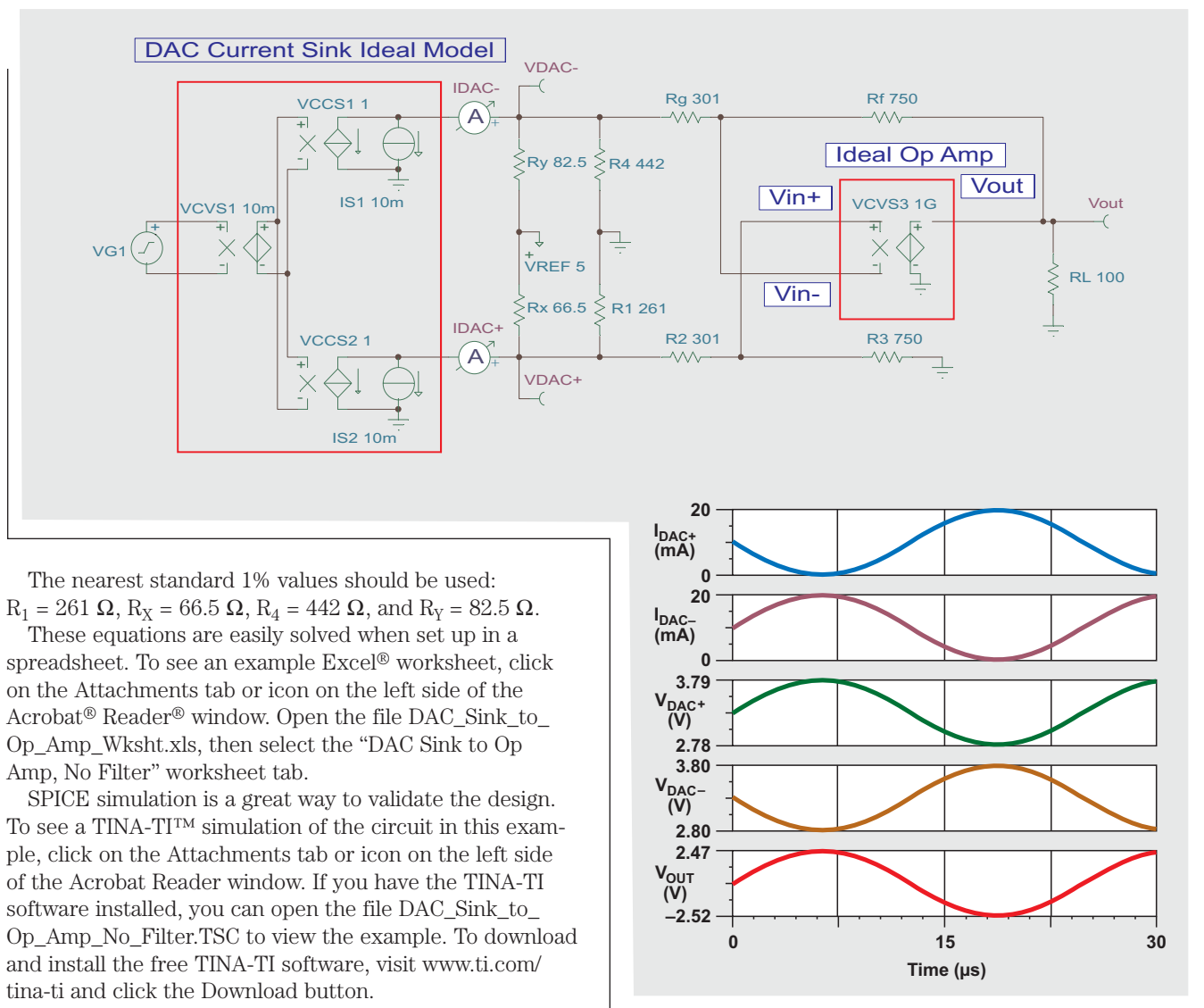

The nearest standard 1% values should be used:  
 $R_1 = 261\ \Omega$ ,  $R_X = 66.5\ \Omega$ ,  $R_4 = 442\ \Omega$ , and  $R_Y = 82.5\ \Omega$ .

These equations are easily solved when set up in a spreadsheet. To see an example Excel® worksheet, click on the Attachments tab or icon on the left side of the Acrobat® Reader® window. Open the file DAC\_Sink\_to\_Op\_Amp\_Wksht.xls, then select the "DAC Sink to Op Amp, No Filter" worksheet tab.

SPICE simulation is a great way to validate the design. To see a TINA-TI™ simulation of the circuit in this example, click on the Attachments tab or icon on the left side of the Acrobat Reader window. If you have the TINA-TI software installed, you can open the file DAC\_Sink\_to\_Op\_Amp\_No\_Filter.TSC to view the example. To download and install the free TINA-TI software, visit [www.ti.com/tina-ti](http://www.ti.com/tina-ti) and click the Download button.

The simulation circuit and waveforms in Figure 6 show that the circuit simulates as expected.  $I_{DAC+}$  and  $I_{DAC-}$  are the DAC currents,  $V_{DAC+}$  and  $V_{DAC-}$  are the voltages developed at the DAC outputs, and  $V_{OUT}$  is the output of the amplifier. The current-sinking DAC and op amp are ideal elements constructed with SPICE macros and are intended to show that the equations derived earlier for  $R_1$ ,  $R_X$ ,  $R_4$ , and  $R_Y$  are valid for ideal elements. Actual performance will vary depending on selected devices.

### DAC image-filter considerations

The DAC output signal will have the desired baseband signal as well as the sampling images that occur at multiples of the sampling frequency. Filtering is usually used to reduce the amplitude of the sampling images because they degrade performance. Filtering directly at the DAC output

before the op amp will preserve the best performance. This is especially important with multitone signals where second-order intermodulation products from the sampling images appear at the baseband.

Filter design is not the topic of this article, so it will not be covered in much detail; but for proper operation the filter component values are calculated based on the input and output impedances seen by the filter. While finding the exact value of the impedance is not so troublesome, it is usually much easier to find standard component values to implement the filter when the input and output impedances to the filter are equal. With this in mind, let's now consider how to achieve the same goals as before while keeping the impedance seen by the filter balanced.

Figure 7 shows the proposed circuit implementation.  $R_1$ ,  $R_X$ ,  $R_4$ , and  $R_Y$  have been replaced with prime and double-prime components on either side of the filter, where

$$\begin{aligned} R_1 &= R'_1 \parallel R''_1, \\ R_X &= R'_X \parallel R''_X, \\ R_4 &= R'_4 \parallel R''_4, \text{ and} \\ R_Y &= R'_Y \parallel R''_Y. \end{aligned}$$

With the additional constraint that the impedance seen on each terminal of the filter is  $2 \times Z_{DAC\pm}$ , the following equations can be derived after quite a lot of algebra:

$$\frac{1}{R'_1} = \frac{1}{2Z_{DAC+} \left( 1 + \frac{1}{\frac{V_{REF}}{V_{DAC+(max)}} - 1} \right)} \quad (12)$$

$$\frac{1}{R''_1} = \frac{1}{2Z_{DAC+} \left( 1 + \frac{1}{\frac{V_{REF}}{V_{DAC+(max)}} - 1} \right)} - \frac{1}{R_2 + R_3} \quad (13)$$

$$\frac{1}{R'_X} = \frac{1}{2Z_{DAC+}} - \frac{1}{R'_1} \quad (14)$$

$$\frac{1}{R''_X} = \frac{1}{2Z_{DAC+}} - \frac{1}{R'_1} - \frac{1}{R_2 + R_3} \quad (15)$$

$$\frac{1}{R'_4} = \frac{\left[ \frac{Z_{DAC+} \times \alpha \left( \frac{R_3}{R_2 + R_3} \right)}{1 - \frac{R_3}{R_2 + R_3}} \right]}{\frac{2Z_{DAC-}}{V_{DAC-(max)} - V_{REF}} + 1} \quad (16)$$

$$\frac{1}{R''_4} = \frac{\frac{Z_{DAC+} \times \alpha \left( \frac{R_3}{R_2 + R_3} \right)}{1 - \frac{R_3}{R_2 + R_3}}}{\frac{2Z_{DAC-}}{V_{DAC-(max)} - V_{REF}} + 1} + \left[ \frac{V_{DAC+(min)} \times \alpha \left( \frac{R_3}{R_2 + R_3} \right) - V_{DAC-(max)}}{V_{REF} - V_{DAC-(max)}} - 1 \right] \left( \frac{1}{R_G} \right) \quad (17)$$

$$\frac{1}{R'_Y} = \frac{1 - \frac{Z_{DAC+} \times \alpha \left( \frac{R_3}{R_2 + R_3} \right)}{R_G}}{2Z_{DAC-}} - \frac{1}{R'_4} \quad (18)$$

$$\frac{1}{R''_Y} = \frac{1 - \frac{Z_{DAC+} \times \alpha \left( \frac{R_3}{R_2 + R_3} \right)}{R_G}}{2Z_{DAC-}} - \left( \frac{1}{R'_4} + \frac{1}{R_G} \right) \quad (19)$$

Figure 7. Inserting DAC image filter

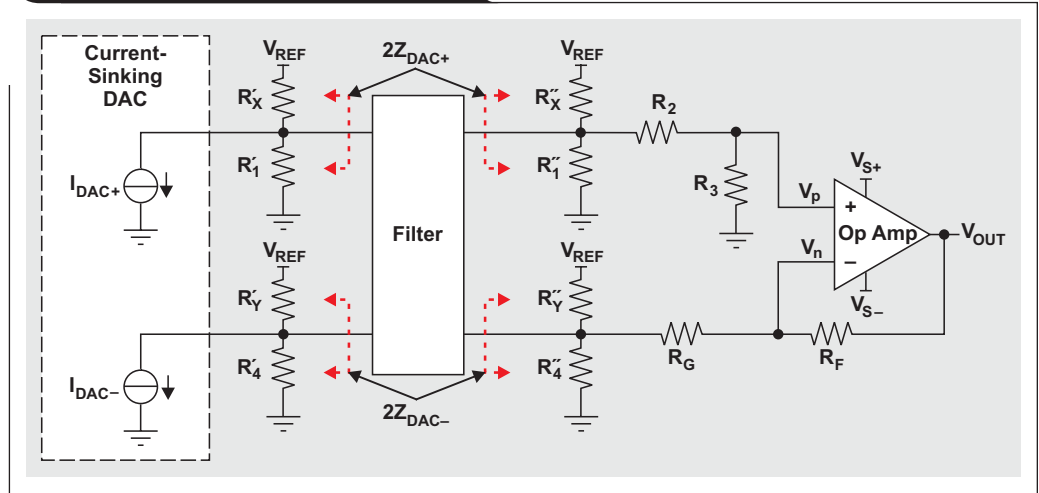

These equations are easily solved when set up in a spreadsheet. To see an example Excel worksheet, click on the Attachments tab or icon on the left side of the Acrobat Reader window. Open the file DAC\_Sink\_to\_Op\_Amp\_Wksht.xls, then select the “DAC Sink to Op Amp, With Filter” worksheet tab.

SPICE simulation is a great way to validate the design. To see a TINA-TI simulation comparing results with a filter used in the circuit, click on the Attachments tab or icon on the left side of the Acrobat Reader window. If you have the TINA-TI software installed, you can open the file DAC\_Sink\_to\_Op\_Amp\_With\_Filter.TSC to view the example. To download and install the free TINA-TI software, visit [www.ti.com/tina-ti](http://www.ti.com/tina-ti) and click the Download button. To show

the effects of balancing the filter impedance, a 100-MHz differential filter designed for 100-Ω input and output impedance is inserted into the interface of the DAC and op amp. In the top circuit, the filter is inserted between the bias resistors and amplifier gain resistors with no regard for balancing the impedance; the output is labeled “V<sub>OUT</sub> No Match1.” In the bottom circuit, the filter is inserted between the DAC and the bias resistors with no regard for balancing the impedance; the output is labeled “V<sub>OUT</sub> No Match2.” In the center circuit, the bias network is designed for 100-Ω balanced impedance; the output is labeled “V<sub>OUT</sub> Matched.” The transient simulation waveforms look the same as those shown in Figure 6 for each of these circuits, but simulation of an AC transfer function (see Figure 8) shows that the unmatched implementations result in significant ripple in the frequency response while the matched design performs as desired.

During design of the Texas Instruments TSW3070 evaluation board, a circuit was derived as shown in Figure 9 that appears to be well-balanced and that provides for proper impedance matching to the

**Figure 8. Simulation of AC transfer function with matched vs. unmatched filter implementations**

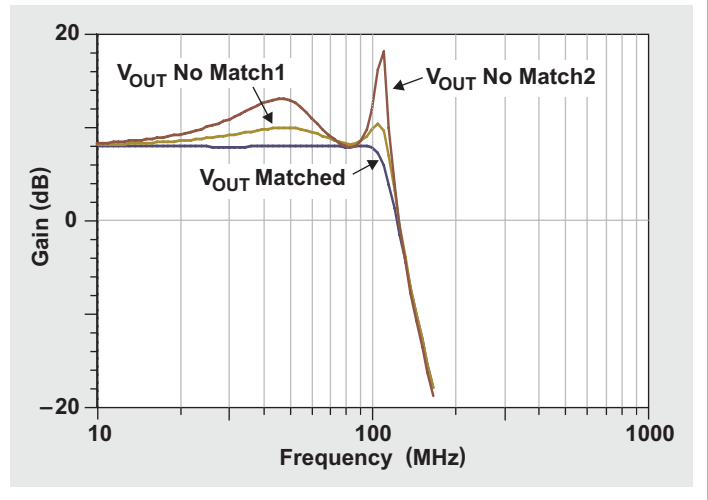

**Figure 9. Original TSW3070 circuit simulation (not balanced)**

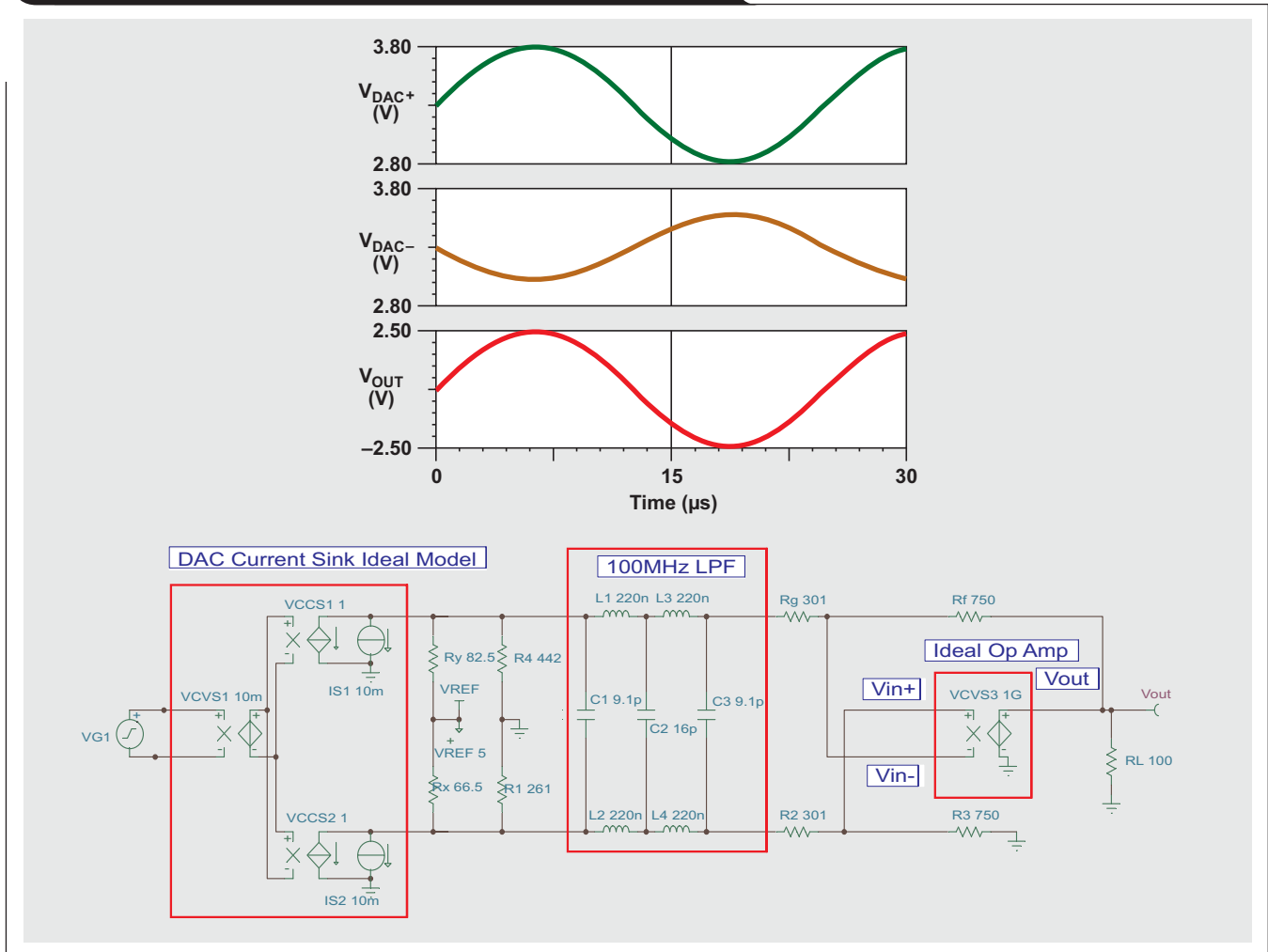



100-MHz low-pass filter (LPF). However, the circuit's simulation waveforms show that the impedances seen by the outputs of the DAC are not balanced and that the voltage at  $V_{DAC+}$  is not the mirror image of that at  $V_{DAC-}$ . Per the last example given, this circuit was modified to balance the impedances for the DAC and the LPF. Performance of the second and third harmonics was tested before and after the modification, and the results (shown in Figure 10) show as much as a 10-dB improvement in the second harmonics (depending on the frequency) with basically no change in the third harmonics.

## Conclusion

This article has shown a circuit implementation using a single-stage op amp to convert complementary-current

outputs from a current-sinking DAC to a single-ended voltage. Equations were derived and a methodology presented for proper selection of component values to set the DAC's output-voltage compliance while maintaining balanced input signals to the op amp for best overall performance. Filter-design considerations were also included to explain proper insertion when filtering before the amplifier is desired.

## Related Web sites

[amplifier.ti.com](http://amplifier.ti.com)

[www.ti.com/sc/device/partnumber](http://www.ti.com/sc/device/partnumber)

Replace *partnumber* with DAC5675A, DAC5681,

DAC5682Z, DAC5686, DAC5687, DAC5688, or THS3095

[www.ti.com/tina-ti](http://www.ti.com/tina-ti)

[www.ti.com/tsw3070](http://www.ti.com/tsw3070)

**Figure 10. Harmonic distortion with balanced versus unbalanced impedance**

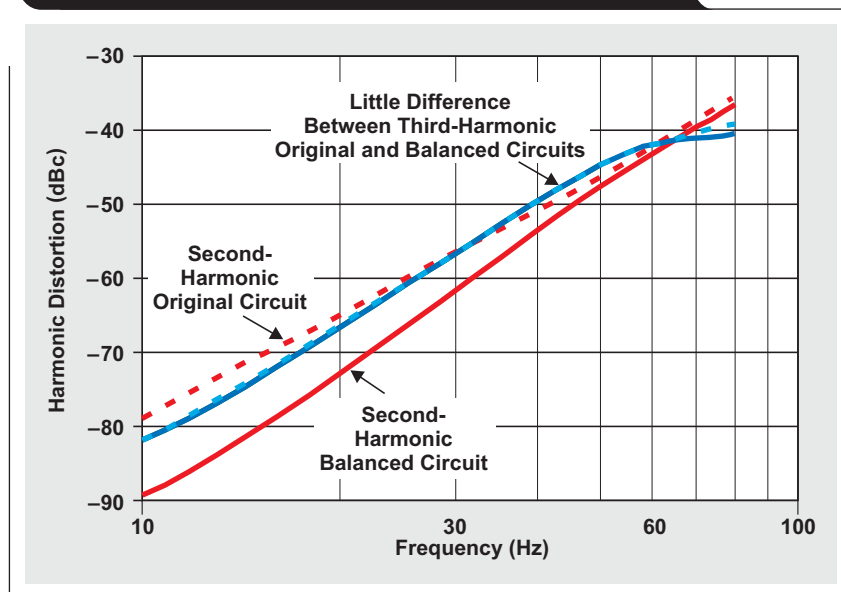

## IMPORTANT NOTICE

Texas Instruments Incorporated and its subsidiaries (TI) reserve the right to make corrections, modifications, enhancements, improvements, and other changes to its products and services at any time and to discontinue any product or service without notice. Customers should obtain the latest relevant information before placing orders and should verify that such information is current and complete. All products are sold subject to TI's terms and conditions of sale supplied at the time of order acknowledgment.

TI warrants performance of its hardware products to the specifications applicable at the time of sale in accordance with TI's standard warranty. Testing and other quality control techniques are used to the extent TI deems necessary to support this warranty. Except where mandated by government requirements, testing of all parameters of each product is not necessarily performed.

TI assumes no liability for applications assistance or customer product design. Customers are responsible for their products and applications using TI components. To minimize the risks associated with customer products and applications, customers should provide adequate design and operating safeguards.

TI does not warrant or represent that any license, either express or implied, is granted under any TI patent right, copyright, mask work right, or other TI intellectual property right relating to any combination, machine, or process in which TI products or services are used. Information published by TI regarding third-party products or services does not constitute a license from TI to use such products or services or a warranty or endorsement thereof. Use of such information may require a license from a third party under the patents or other intellectual property of the third party, or a license from TI under the patents or other intellectual property of TI.

Reproduction of information in TI data books or data sheets is permissible only if reproduction is without alteration and is accompanied by all associated warranties, conditions, limitations, and notices. Reproduction of this information with alteration is an unfair and deceptive business practice. TI is not responsible or liable for such altered documentation. Information of third parties may be subject to additional restrictions.

Resale of TI products or services with statements different from or beyond the parameters stated by TI for that product or service voids all express and any implied warranties for the associated TI product or service and is an unfair and deceptive business practice. TI is not responsible or liable for any such statements.

TI products are not authorized for use in safety-critical applications (such as life support) where a failure of the TI product would reasonably be expected to cause severe personal injury or death, unless officers of the parties have executed an agreement specifically governing such use. Buyers represent that they have all necessary expertise in the safety and regulatory ramifications of their applications, and acknowledge and agree that they are solely responsible for all legal, regulatory and safety-related requirements concerning their products and any use of TI products in such safety-critical applications, notwithstanding any applications-related information or support that may be provided by TI. Further, Buyers must fully indemnify TI and its representatives against any damages arising out of the use of TI products in such safety-critical applications.

TI products are neither designed nor intended for use in military/aerospace applications or environments unless the TI products are specifically designated by TI as military-grade or "enhanced plastic." Only products designated by TI as military-grade meet military specifications. Buyers acknowledge and agree that any such use of TI products which TI has not designated as military-grade is solely at the Buyer's risk, and that they are solely responsible for compliance with all legal and regulatory requirements in connection with such use.

TI products are neither designed nor intended for use in automotive applications or environments unless the specific TI products are designated by TI as compliant with ISO/TS 16949 requirements. Buyers acknowledge and agree that, if they use any non-designated products in automotive applications, TI will not be responsible for any failure to meet such requirements.

Following are URLs where you can obtain information on other Texas Instruments products and application solutions:

<b>Products</b>		<b>Applications</b>	
Amplifiers	<a href="http://amplifier.ti.com">amplifier.ti.com</a>	Audio	<a href="http://www.ti.com/audio">www.ti.com/audio</a>
Data Converters	<a href="http://dataconverter.ti.com">dataconverter.ti.com</a>	Automotive	<a href="http://www.ti.com/automotive">www.ti.com/automotive</a>
DLP® Products	<a href="http://www.dlp.com">www.dlp.com</a>	Broadband	<a href="http://www.ti.com/broadband">www.ti.com/broadband</a>
DSP	<a href="http://dsp.ti.com">dsp.ti.com</a>	Digital Control	<a href="http://www.ti.com/digitalcontrol">www.ti.com/digitalcontrol</a>
Clocks and Timers	<a href="http://www.ti.com/clocks">www.ti.com/clocks</a>	Medical	<a href="http://www.ti.com/medical">www.ti.com/medical</a>
Interface	<a href="http://interface.ti.com">interface.ti.com</a>	Military	<a href="http://www.ti.com/military">www.ti.com/military</a>
Logic	<a href="http://logic.ti.com">logic.ti.com</a>	Optical Networking	<a href="http://www.ti.com/opticalnetwork">www.ti.com/opticalnetwork</a>
Power Mgmt	<a href="http://power.ti.com">power.ti.com</a>	Security	<a href="http://www.ti.com/security">www.ti.com/security</a>
Microcontrollers	<a href="http://microcontroller.ti.com">microcontroller.ti.com</a>	Telephony	<a href="http://www.ti.com/telephony">www.ti.com/telephony</a>
RFID	<a href="http://www.ti-rfid.com">www.ti-rfid.com</a>	Video & Imaging	<a href="http://www.ti.com/video">www.ti.com/video</a>
RF/IF and ZigBee® Solutions	<a href="http://www.ti.com/lprf">www.ti.com/lprf</a>	Wireless	<a href="http://www.ti.com/wireless">www.ti.com/wireless</a>

Mailing Address: Texas Instruments  
Post Office Box 655303  
Dallas, Texas 75265

# TI Worldwide Technical Support

---

## Internet

### TI Semiconductor Product Information Center Home Page

[support.ti.com](http://support.ti.com)

### TI Semiconductor KnowledgeBase Home Page

[support.ti.com/sc/knowledgebase](http://support.ti.com/sc/knowledgebase)

## Product Information Centers

<b>Americas</b>	Phone	+1(972) 644-5580
<b>Brazil</b>	Phone	0800-891-2616
<b>Mexico</b>	Phone	0800-670-7544
	Fax	+1(972) 927-6377
	Internet/Email	<a href="http://support.ti.com/sc/pic/americas.htm">support.ti.com/sc/pic/americas.htm</a>

## Europe, Middle East, and Africa

Phone	
European Free Call	00800-ASK-TEXAS (00800 275 83927)
International	+49 (0) 8161 80 2121
Russian Support	+7 (4) 95 98 10 701

**Note:** The European Free Call (Toll Free) number is not active in all countries. If you have technical difficulty calling the free call number, please use the international number above.

Fax	+ (49) (0) 8161 80 2045
Internet	<a href="http://support.ti.com/sc/pic/euro.htm">support.ti.com/sc/pic/euro.htm</a>

## Japan

Fax	International	+81-3-3344-5317
	Domestic	0120-81-0036
Internet/Email	International	<a href="http://support.ti.com/sc/pic/japan.htm">support.ti.com/sc/pic/japan.htm</a>
	Domestic	<a href="http://www.tij.co.jp/pic">www.tij.co.jp/pic</a>

## Asia

Phone	
International	+91-80-41381665
Domestic	<u>Toll-Free Number</u>
Australia	1-800-999-084
China	800-820-8682
Hong Kong	800-96-5941
India	1-800-425-7888
Indonesia	001-803-8861-1006
Korea	080-551-2804
Malaysia	1-800-80-3973
New Zealand	0800-446-934
Philippines	1-800-765-7404
Singapore	800-886-1028
Taiwan	0800-006800
Thailand	001-800-886-0010
Fax	+886-2-2378-6808
Email	<a href="mailto:tiasia@ti.com">tiasia@ti.com</a> or <a href="mailto:ti-china@ti.com">ti-china@ti.com</a>
Internet	<a href="http://support.ti.com/sc/pic/asia.htm">support.ti.com/sc/pic/asia.htm</a>

**Safe Harbor Statement:** This publication may contain forward-looking statements that involve a number of risks and uncertainties. These "forward-looking statements" are intended to qualify for the safe harbor from liability established by the Private Securities Litigation Reform Act of 1995. These forward-looking statements generally can be identified by phrases such as TI or its management "believes," "expects," "anticipates," "foresees," "forecasts," "estimates" or other words or phrases of similar import. Similarly, such statements herein that describe the company's products, business strategy, outlook, objectives, plans, intentions or goals also are forward-looking statements. All such forward-looking statements are subject to certain risks and uncertainties that could cause actual results to differ materially from those in forward-looking statements. Please refer to TI's most recent Form 10-K for more information on the risks and uncertainties that could materially affect future results of operations. We disclaim any intention or obligation to update any forward-looking statements as a result of developments occurring after the date of this publication.

**E093008**

TINA-TI is a trademark of Texas Instruments. All other trademarks are the property of their respective owners.