

# D-CAP™ Mode With All-Ceramic Output Capacitor Application

Nancy Zhang, Wenkai Wu, Weidong Zhu

DCS Computing Power Management

## ABSTRACT

The TI D-CAP™ Mode controller is widely used in computing power management. D-CAP™ Mode requires an appropriate amount of equivalent series resistance (ESR) on output capacitors to ensure the loop stability. However, many customers prefer to use a low-ESR capacitor such as a ceramic output capacitor. Sufficient output ripple, however, may not be available in this case to ensure the system stability. This application report introduces an implementation of D-CAP™ Mode with all-ceramic capacitor application using a ripple injection approach. 陶瓷电容

First, the basic D-CAP™ Mode operation is described. Then, the ripple injection approach is introduced to ensure system stability. Last, the step-by-step components selection procedure is provided. The performance of TPS53219EVM with all-ceramic output capacitor using ripple injection approach is demonstrated. This ripple injection approach can be applied to TPS51116, TPS51117, TPS51315, TPS51218, TPS53219, and other single D-CAP™ Mode controllers with low- output voltage application. Texas Instruments does not recommend using the ripple injection on the dual D-CAP™ Mode controllers because it might cause channel-to-channel interference issues.

## 1 Introduction

The D-CAP™ abbreviation stands for “Direct connection to the output CAPacitor.” D-CAP™ Mode control provides many attractive features:

- Ease of use with no loop compensation
- Minimum external components
- Fast transient response which reduces output capacitance, saving board space and cost
- High efficiency for both heavy and light load

/ Figure 1 is basic block diagram of D-CAP™ mode control with adaptive on-time modulator. D-CAP™ Mode actually has three fundamental components listed as follows.

- ▲ 1. The output capacitor with ESR.
2. PWM comparator compares VFB with VREF directly.
3. On-time timer to generate pseudo constant frequency.

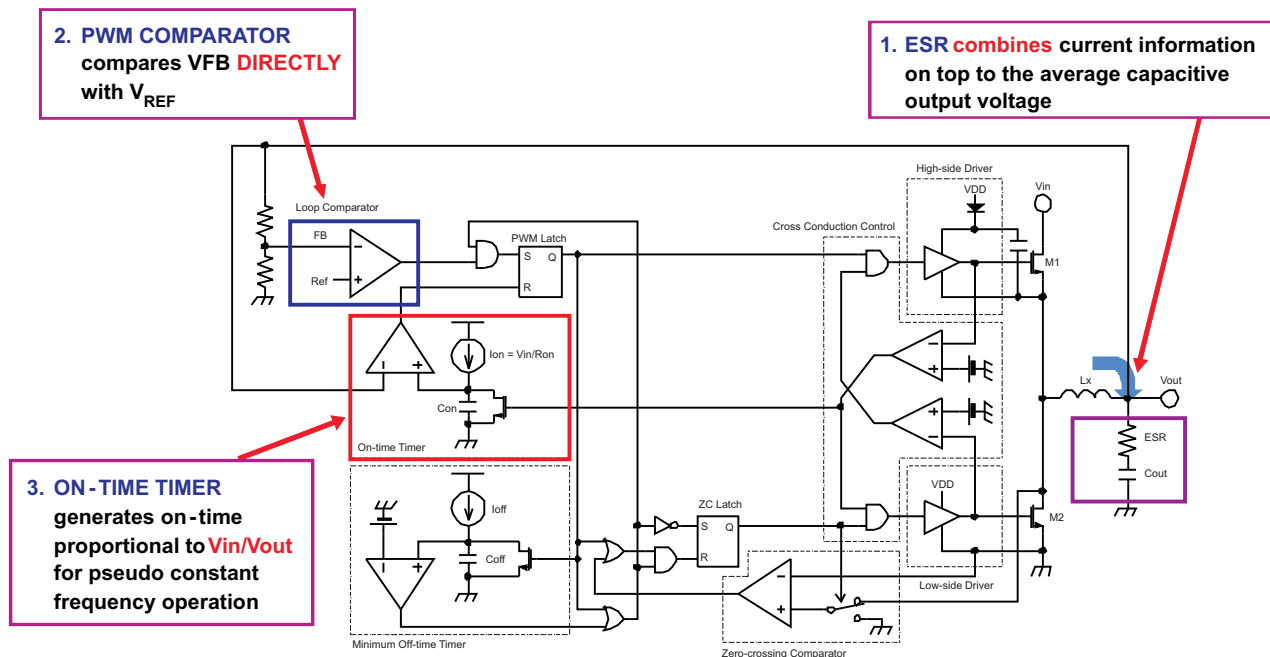


Figure 1. D-CAP™ Mode With Adaptive On-Time Modulator Block Diagram

Figure 2 illustrates the operation of D-CAP™ Mode with adaptive on-time control. At the beginning of each cycle, the high-side MOSFET M1 is turned on. M1 is turned off after the internal one-shot timer expires. The on-time is determined by feed forwarding  $V_{in}$  and  $V_{out}$  to keep frequency fairly constant over input voltage range. Hence, it is called adaptive on-time control. M1 is turned on again when the feedback voltage declines to  $V_{ref}$  which indicates insufficient output voltage. Repeating the operation in this manner, the controller regulates the output voltage. The rectifying MOSFET M2 is turned on in each OFF state to keep the conduction loss at minimum. M2 is turned off when the inductor current reaches zero. This enables a seamless transition to the reduced frequency at light-load condition so that high efficiency is achieved from full load to light load.

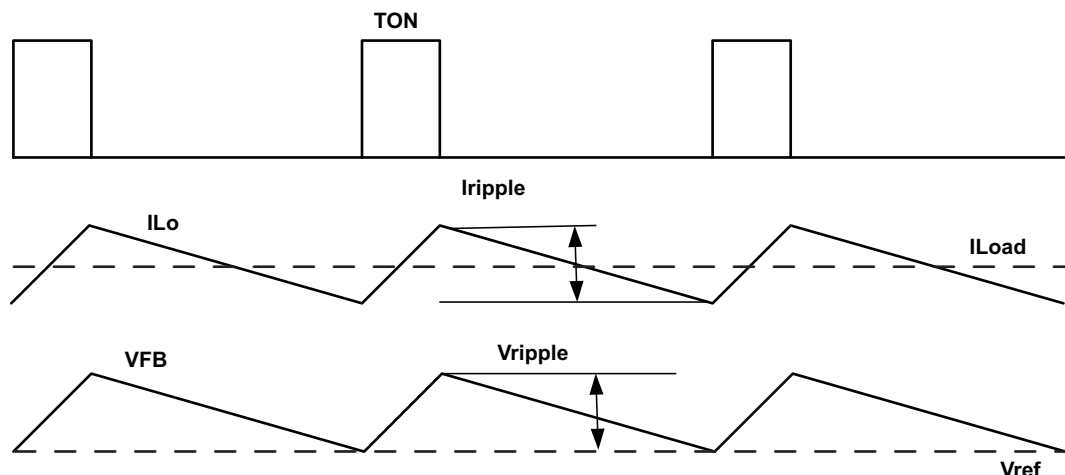


Figure 2. D-CAP™ Mode With Adaptive On-Time Operation

In D-CAP™ Mode, the output voltage is directly compared by the PWM comparator. Theoretically, the gain and bandwidth of a comparator are infinite. So, the loop gain from the output node becomes infinite. This means that the loop transfer function which uses the output node voltage as a state variable is not

derivable and not measurable as well. As for the stability analysis, a loop transfer function that uses an intrinsic capacitance node voltage as a state variable is derivable. The loop stability of D-CAP™ Mode is determined by certain ESR of the output capacitor. The proper ESR of the output capacitor keeps the loop stable and results in less PWM jitter. The loop stability criteria and jitter requirement are demonstrated as follows.

1. Loop stability criteria:

$$f_0 = \frac{1}{2\pi \times \text{ESR} \times C_o} < \frac{f_{sw}}{3} \quad (1)$$

2. Jitter Performance: Required 10-mV to 15-mV ripple at VFB pin; usually, choose 12 mV (for higher output voltage, higher injected ripple may be needed).

$$\text{ESR} \geq \frac{V_{out} \times 12 \text{ mV}}{V_{ref} \times I_{Ripple}} \quad (2)$$

For application with all-ceramic output capacitors, the ESR is usually too small to meet the preceding criteria. Double pulse or more jitter might be shown on the PWM waveforms. In this case, the ripple injection approach can be used for injecting a small virtual ripple into the VFB pin to make the D-CAP™ Mode stable. This application report shows how to implement a ripple injection network and what the performance looks like.

## 2 Ripple Injection Approach

Figure 3 shows the ripple injection network. This approach is simple and only composed of two capacitors and one resistor.  $R_r$  and  $C_r$  across inductor generates the ripple by using DCR of the inductor. This ripple voltage is analogous to ripple voltage generated across the ESR of a standard capacitor. The ripple voltage is then coupled into the feedback VFB pin through  $C_c$ .  $C_c$  is used to isolate the dc voltage because only a small ac ripple voltage is needed.

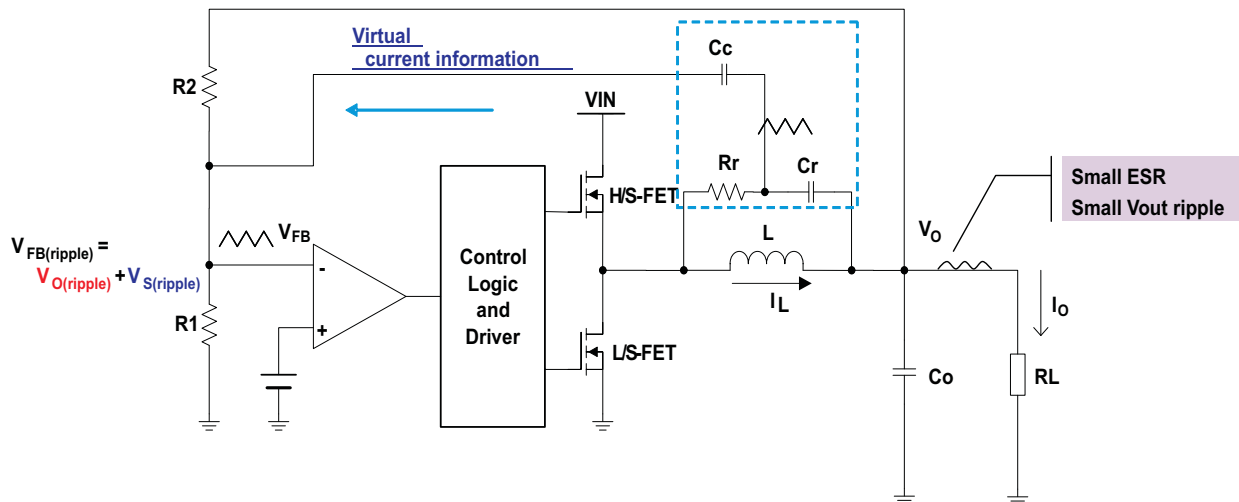


Figure 3. D-CAP™ Mode With Ripple Injection Approach

New loop stability criteria for D-CAP™ Mode with ripple injection approach:

$$\frac{L \times C_o}{R_r \times C_r} > \frac{T_{on}}{2} \quad (3)$$

$$C_r > C_c > \frac{1}{2\pi \times f_{sw} \times \left( \frac{R1 \times R2}{R1 + R2} \right)} \quad (4)$$

### 3 R<sub>r</sub>, C<sub>r</sub>, and C<sub>c</sub> Selection Procedure

The following step-by-step design procedure shows how to choose this ripple injection network R<sub>r</sub>, C<sub>r</sub>, and C<sub>c</sub>. TPS53219EVM is used as an example.

V<sub>in</sub>: 12 V  
V<sub>out</sub>: 1.1 V  
I<sub>out</sub>: 0 A - 25 A  
Inductor L: 0.44 μH, DCR: 0.32 mΩ  
Switching frequency f<sub>sw</sub>: 300 kHz  
Output capacitor C<sub>o</sub>: 5 x 100 μF = 500 μF ceramic capacitors, ESR: 0.4 mΩ  
R1: 10 kΩ, R2: 8.25 kΩ  
Ton: PWM on time

- Select R<sub>r</sub>C<sub>r</sub>: Inject at approximately 12-mV virtual ripple at VFB pin.
  - R<sub>r</sub>C<sub>r</sub> = L/DCR, means you extract the same ripple from the DCR of the inductor to VFB pin.
  - R<sub>r</sub>C<sub>r</sub> > L/DCR, means you extract the smaller ripple from the DCR of the inductor to VFB pin; the transient may be good but may have heavier PWM jitter.
  - R<sub>r</sub>C<sub>r</sub> < L/DCR, means you extract the larger ripple from the DCR of the inductor to VFB pin; the transient may be sacrificed a little for less PWM jitter.

$$\begin{aligned}
 I_{\text{Ripple}} &= \frac{(V_{\text{in}} - V_{\text{out}}) \times V_{\text{out}}}{L \times f_{\text{sw}} \times V_{\text{in}}} & I_{\text{Ripple}} &= 7.57 \text{ A} \\
 V_{\text{Ind\_DCR\_Ripple}} &= I_{\text{Ripple}} \times \text{DC} & V_{\text{Ind\_DCR\_Ripple}} &= 2.422 \text{ mV} \\
 V_{\text{CO\_Ripple}} &= \frac{I_{\text{Ripple}}}{8 \times C_{\text{o}} \times f_{\text{sw}}} & V_{\text{CO\_Ripple}} &= 6.31 \text{ mV} \\
 V_{\text{INJ\_Ripple}} &= \max(V_{\text{CO\_Ripple}}, 12 \text{ mV}) & V_{\text{INJ\_Ripple}} &= 12 \text{ mV} \\
 k &= \frac{V_{\text{INJ\_Ripple}}}{V_{\text{INJ\_DCR\_Ripple}}} & k &= 4.955 \text{ k Ripple injection ratio} \\
 R_{\text{r}} \times C_{\text{r}} &= \frac{L}{k \times \text{DCR}} & R_{\text{r}} \times C_{\text{r}} &= 0.000277
 \end{aligned}$$

(5)

- Ensure that R<sub>r</sub>C<sub>r</sub> satisfies the loop stability:

$$\begin{aligned}
 \frac{L \times C_{\text{o}}}{R_{\text{r}} \times C_{\text{r}}} &> \frac{T_{\text{on}}}{2} \\
 \frac{L \times C_{\text{o}}}{R_{\text{r}} \times C_{\text{r}}} &= 0.794 \times 10^{-6} > \frac{T_{\text{on}}}{2} = 0.153 \times 10^{-6}
 \end{aligned}$$

(6)

- Set R<sub>r</sub> = 10 kΩ, then calculate C<sub>r</sub> = 0.027 μF or set C<sub>r</sub>, then calculate R<sub>r</sub>.

- C<sub>c</sub> selection:

C<sub>c</sub> is used to isolate dc voltage. If C<sub>c</sub> is large, the transient is slower. If the C<sub>c</sub> is small, the transient is faster. So, C<sub>c</sub> = 1000 pF is recommended. This value is good for most applications. [Figure 4](#) shows the C<sub>c</sub> value impact on the transient response.

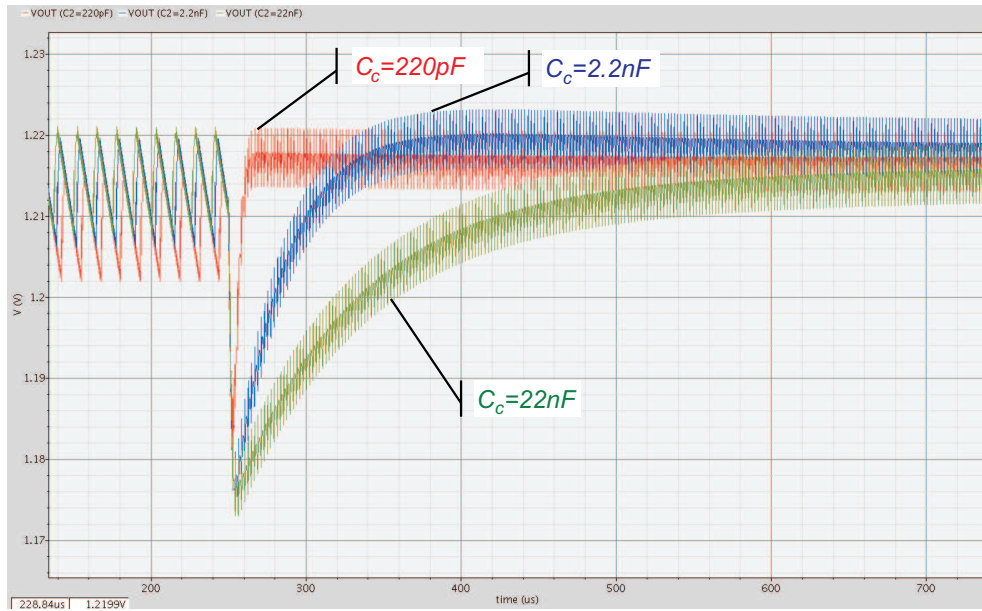


Figure 4. Transient Response for Different Cc Values

5. Ensure that Cr, Cc meet the new loop stability:

$$C_r > C_c > \frac{1}{2\pi \times f_{sw} \times \left( \frac{R1 * R2}{R1 + R2} \right)}$$

$$\frac{1}{2\pi \times f_{sw} \times \left( \frac{R1 \times R2}{R1 + R2} \right)} = 117 \text{ pF}$$

$$C_r = 0.027 \text{ } \mu\text{F}$$

$$C_c = 1000 \text{ pF}$$

(7)

6. Check the output dc voltage accuracy.

$$\text{ESR} = 0.4 \text{ m}\Omega$$

$$V_{\text{ESR\_Ripple}} = \text{ESR} \times I_{\text{Ripple}} \quad V_{\text{ESR\_Ripple}} = 3.028 \text{ mV}$$

(8)

So, total approximate average ripple voltage at feedback VFB pin is:

$$V_{\text{FB\_Ripple}} = V_{\text{ESR\_Ripple}} + V_{\text{CO\_Ripple}} + 12\text{mV}$$

$$V_{\text{FB\_Ripple}} = 21.338 \text{ mV}$$

$$V_{\text{ref}} = 0.6 \text{ V}$$

$$V_{\text{FB}} = V_{\text{ref}} + \frac{V_{\text{FB\_Ripple}}}{2}$$

$$V_{\text{FB}} = 0.6107 \text{ V}$$

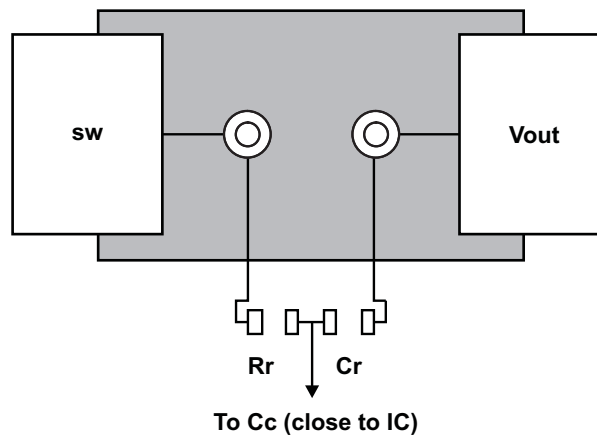
$$V_{\text{out}} = \left( \frac{R1 + R2}{R1} \right) \times V_{\text{FB}}$$

$$V_{\text{out}} = 1.115 \text{ V}$$

(9)

7. Ripple injection parts layout consideration:

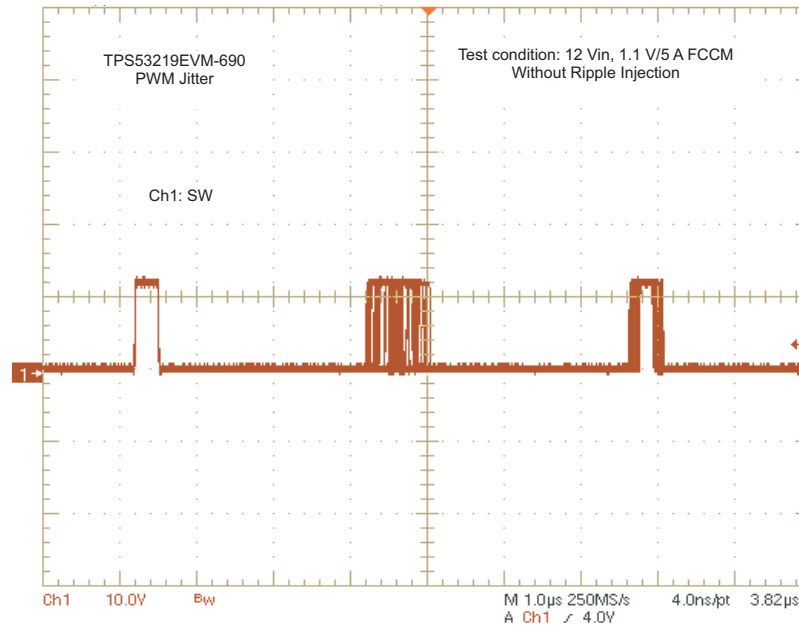
Rr and Cr must be placed close to the inductor and Cc must be close to the IC as shown in [Figure 5](#).

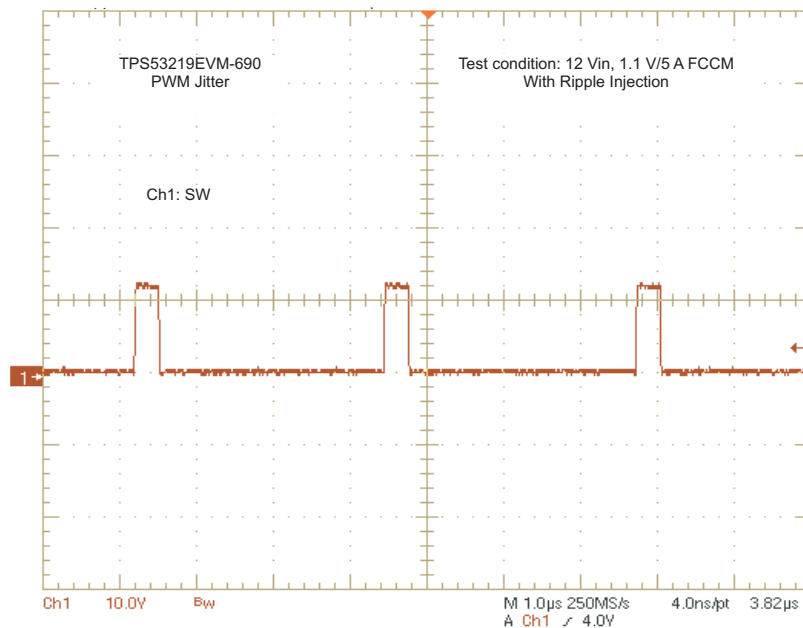

**Figure 5. Ripple Injection Network Layout Consideration**

#### 4 The Performance of TPS53219EVM With All-Ceramic Output Capacitor

The TPS53219 is a D-CAP™ Mode with adaptive on-time controller. Usually, the TPS53219 needs an output capacitor with certain ESR for proper operation. However, equivalent or superior performance can be obtained by using an all-ceramic output capacitor and ripple injection approach.

Based on the design procedure described in this application report, the following values were derived:  $R_r = 10\text{ k}\Omega$ ,  $C_r = 0.027\text{ }\mu\text{F}$ ,  $C_c = 1000\text{ pF}$ . Figure 6 shows the PWM waveform that has double pulse and heavy jitter without ripple injection. Figure 7 shows the waveform that has no double pulse and less jitter with the ripple injection.


**Figure 6. 12-Vin, 1.2-V/5-A All-Ceramic Capacitor Without Ripple Injection**



**Figure 7. 12-Vin, 1.2-V/5-A All-Ceramic Capacitor With Ripple Injection**

The bode plot is not measurable for the D-CAP™ Mode with an adaptive on-time modulator. However, a bode plot for D-CAP™ Mode with ripple injection can be measured, and it can provide a rough idea about loop stability. (It is worthwhile to mention that the measured bandwidth is not related to the real transient performance because a small-signal model is not applicable to the large-signal controller, i.e., D-CAP™ Mode control).

**Figure 8** is the bode plot for TPS53219EVM with all-ceramic capacitor application. Test condition: 12 Vin, 1.1 V/25 A, crossover frequency: 21.43 kHz, phase margin: 85.50 degrees, gain margin: -21.58 dB.

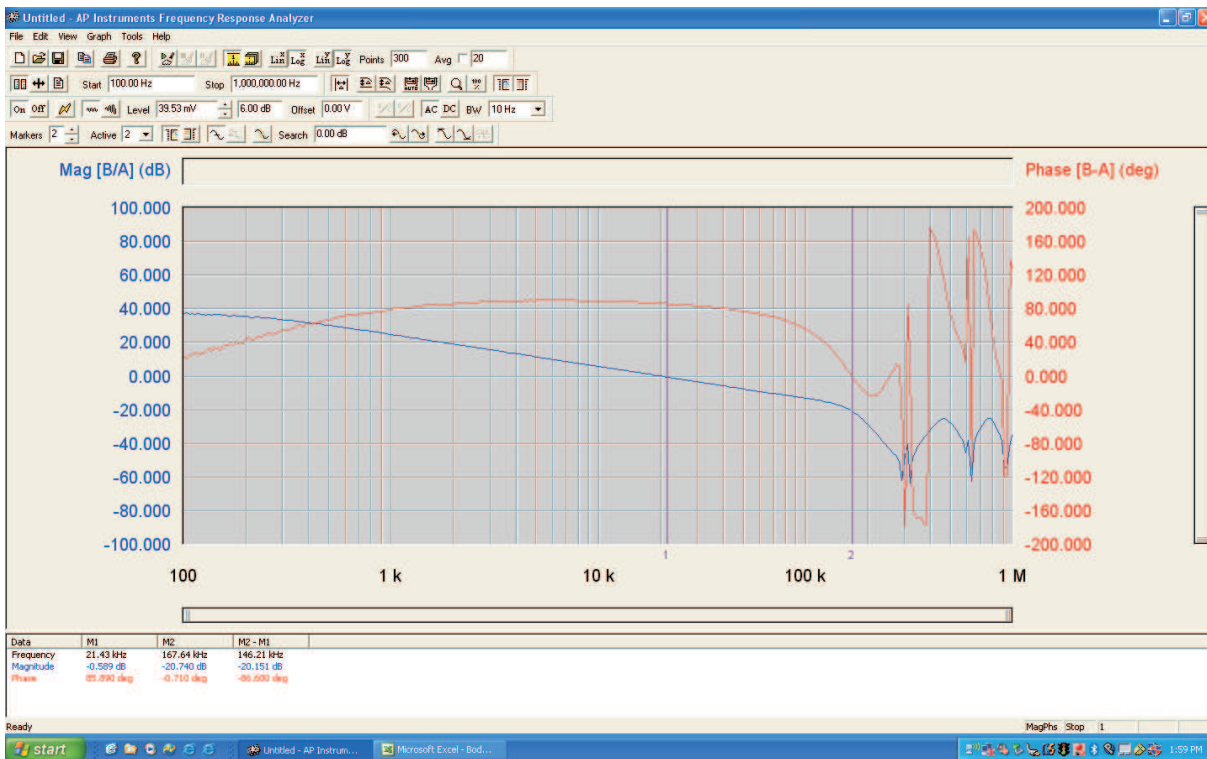


Figure 8. Bode Plot for TPS53219EVM With All-Ceramic Capacitor Application

## 5 Conclusions

The D-CAP™ Mode control was introduced to satisfy the market requirement of low-cost, high-performance, dc-dc converters. The ripple injection approach overcomes the limitation of the original D-CAP™ Mode control. The D-CAP™ Mode with all-ceramic output capacitor and ripple injection approach shows superior performance and ease of use.

## 6 References

1. Tetsuo Tateishi, *The D-CAP™ Mode operation and an implementation of the OOA™ skip mode*, TI's Integrated Power Conference 2005
2. *Adaptive Constant On-Time (D-CAP™) Control Study In Notebook Applications* application report ([SLVA281](#))
3. Wenkai Wu, *The D-CAP™ Mode with all ceramic output design procedure*, Presentation, 2010
4. *TPS53219, Wide Input Voltage, Eco-mode™, Single Synchronous Step-Down Controller* data sheet ([SLUSA08](#))
5. *Using the TPS53219EVM-690 Wide-Input Voltage, Eco-mode™, Single, Synchronous, Step-Down Controller* user's guide ([SLVU431](#))



## IMPORTANT NOTICE

Texas Instruments Incorporated and its subsidiaries (TI) reserve the right to make corrections, modifications, enhancements, improvements, and other changes to its products and services at any time and to discontinue any product or service without notice. Customers should obtain the latest relevant information before placing orders and should verify that such information is current and complete. All products are sold subject to TI's terms and conditions of sale supplied at the time of order acknowledgment.

TI warrants performance of its hardware products to the specifications applicable at the time of sale in accordance with TI's standard warranty. Testing and other quality control techniques are used to the extent TI deems necessary to support this warranty. Except where mandated by government requirements, testing of all parameters of each product is not necessarily performed.

TI assumes no liability for applications assistance or customer product design. Customers are responsible for their products and applications using TI components. To minimize the risks associated with customer products and applications, customers should provide adequate design and operating safeguards.

TI does not warrant or represent that any license, either express or implied, is granted under any TI patent right, copyright, mask work right, or other TI intellectual property right relating to any combination, machine, or process in which TI products or services are used. Information published by TI regarding third-party products or services does not constitute a license from TI to use such products or services or a warranty or endorsement thereof. Use of such information may require a license from a third party under the patents or other intellectual property of the third party, or a license from TI under the patents or other intellectual property of TI.

Reproduction of TI information in TI data books or data sheets is permissible only if reproduction is without alteration and is accompanied by all associated warranties, conditions, limitations, and notices. Reproduction of this information with alteration is an unfair and deceptive business practice. TI is not responsible or liable for such altered documentation. Information of third parties may be subject to additional restrictions.

Resale of TI products or services with statements different from or beyond the parameters stated by TI for that product or service voids all express and any implied warranties for the associated TI product or service and is an unfair and deceptive business practice. TI is not responsible or liable for any such statements.

TI products are not authorized for use in safety-critical applications (such as life support) where a failure of the TI product would reasonably be expected to cause severe personal injury or death, unless officers of the parties have executed an agreement specifically governing such use. Buyers represent that they have all necessary expertise in the safety and regulatory ramifications of their applications, and acknowledge and agree that they are solely responsible for all legal, regulatory and safety-related requirements concerning their products and any use of TI products in such safety-critical applications, notwithstanding any applications-related information or support that may be provided by TI. Further, Buyers must fully indemnify TI and its representatives against any damages arising out of the use of TI products in such safety-critical applications.

TI products are neither designed nor intended for use in military/aerospace applications or environments unless the TI products are specifically designated by TI as military-grade or "enhanced plastic." Only products designated by TI as military-grade meet military specifications. Buyers acknowledge and agree that any such use of TI products which TI has not designated as military-grade is solely at the Buyer's risk, and that they are solely responsible for compliance with all legal and regulatory requirements in connection with such use.

TI products are neither designed nor intended for use in automotive applications or environments unless the specific TI products are designated by TI as compliant with ISO/TS 16949 requirements. Buyers acknowledge and agree that, if they use any non-designated products in automotive applications, TI will not be responsible for any failure to meet such requirements.

Following are URLs where you can obtain information on other Texas Instruments products and application solutions:

### Products

Audio	<a href="http://www.ti.com/audio">www.ti.com/audio</a>
Amplifiers	<a href="http://amplifier.ti.com">amplifier.ti.com</a>
Data Converters	<a href="http://dataconverter.ti.com">dataconverter.ti.com</a>
DLP® Products	<a href="http://www.dlp.com">www.dlp.com</a>
DSP	<a href="http://dsp.ti.com">dsp.ti.com</a>
Clocks and Timers	<a href="http://www.ti.com/clocks">www.ti.com/clocks</a>
Interface	<a href="http://interface.ti.com">interface.ti.com</a>
Logic	<a href="http://logic.ti.com">logic.ti.com</a>
Power Mgmt	<a href="http://power.ti.com">power.ti.com</a>
Microcontrollers	<a href="http://microcontroller.ti.com">microcontroller.ti.com</a>
RFID	<a href="http://www.ti-rfid.com">www.ti-rfid.com</a>
RF/IF and ZigBee® Solutions	<a href="http://www.ti.com/lprf">www.ti.com/lprf</a>

### Applications

Communications and Telecom	<a href="http://www.ti.com/communications">www.ti.com/communications</a>
Computers and Peripherals	<a href="http://www.ti.com/computers">www.ti.com/computers</a>
Consumer Electronics	<a href="http://www.ti.com/consumer-apps">www.ti.com/consumer-apps</a>
Energy and Lighting	<a href="http://www.ti.com/energy">www.ti.com/energy</a>
Industrial	<a href="http://www.ti.com/industrial">www.ti.com/industrial</a>
Medical	<a href="http://www.ti.com/medical">www.ti.com/medical</a>
Security	<a href="http://www.ti.com/security">www.ti.com/security</a>
Space, Avionics and Defense	<a href="http://www.ti.com/space-avionics-defense">www.ti.com/space-avionics-defense</a>
Transportation and Automotive	<a href="http://www.ti.com/automotive">www.ti.com/automotive</a>
Video and Imaging	<a href="http://www.ti.com/video">www.ti.com/video</a>
Wireless	<a href="http://www.ti.com/wireless-apps">www.ti.com/wireless-apps</a>

TI E2E Community Home Page

[e2e.ti.com](http://e2e.ti.com)

Mailing Address: Texas Instruments, Post Office Box 655303, Dallas, Texas 75265  
Copyright © 2011, Texas Instruments Incorporated