

APPROPHOTO PROPRIETARY		
Title		
36 PIN CONNECTOR FOR SENSOR INTERFACE		
Size	Document Number	Rev
A3	APTINA MT9J003 10M CMOS SENSOR BOARD	0.3
Date:	Friday, March 02, 2012	Sheet 1 of 3

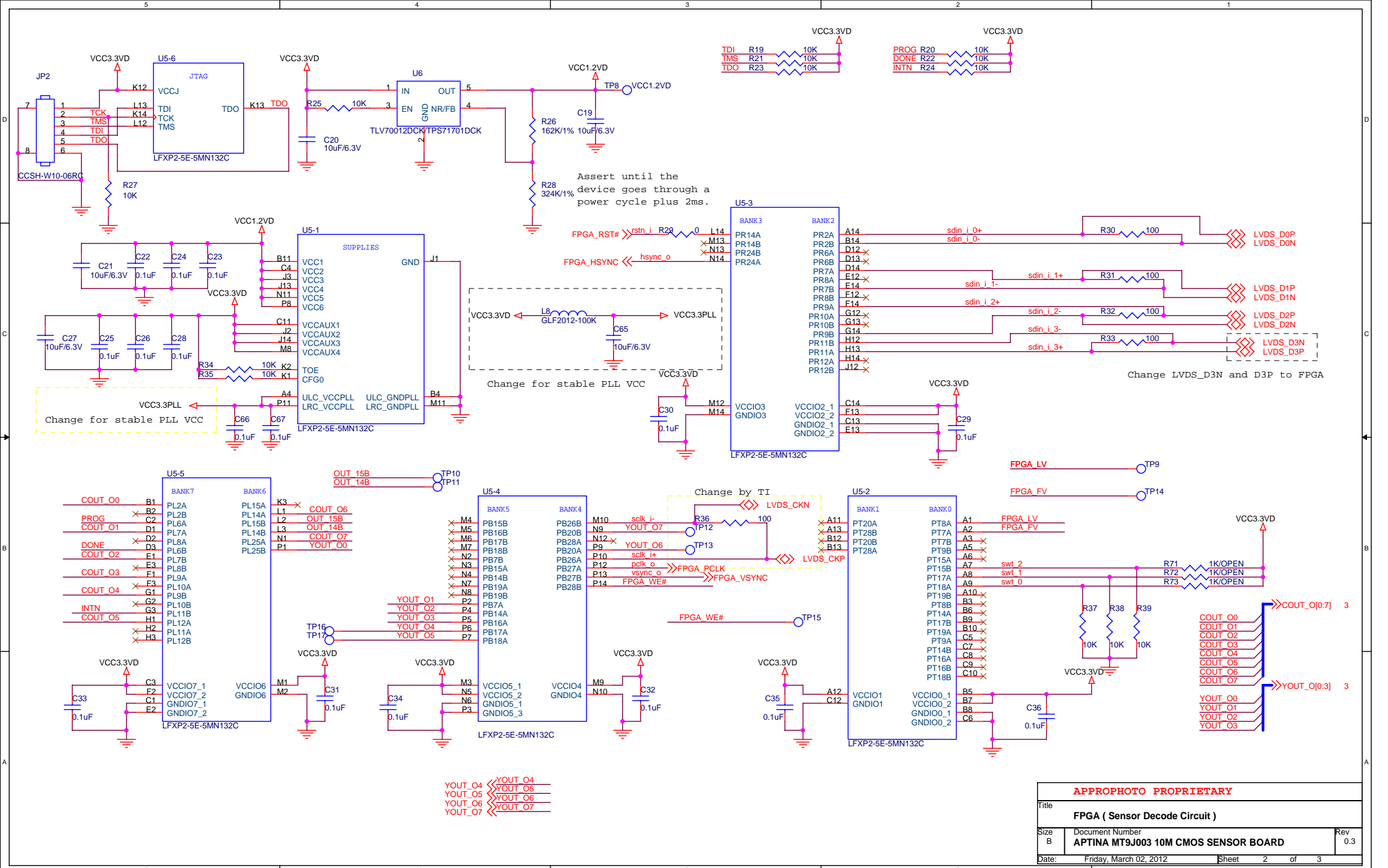

APPROPHOTO PROPRIETARY		
Title FPGA (Sensor Decode Circuit)		
Size B	Document Number APTINA MT9J003 10M CMOS SENSOR BOARD	Rev 0.3
Date: Friday, March 02, 2012	Sheet 2	of 3

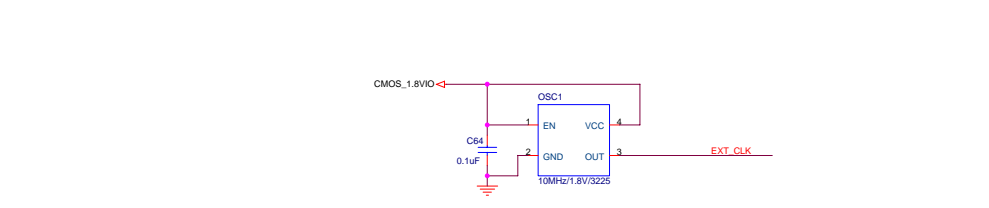
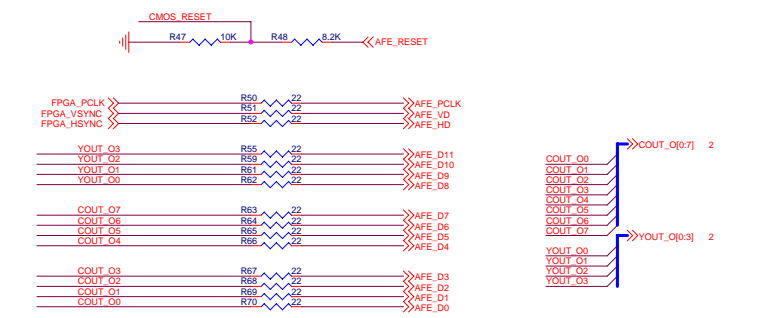
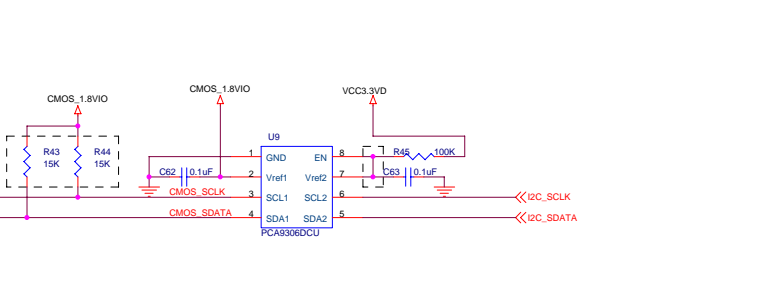
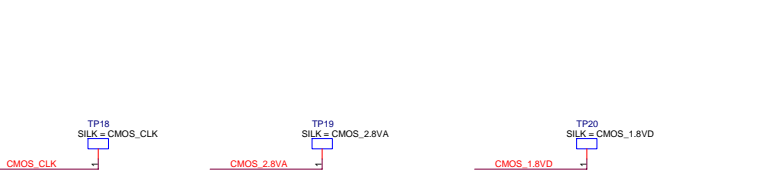
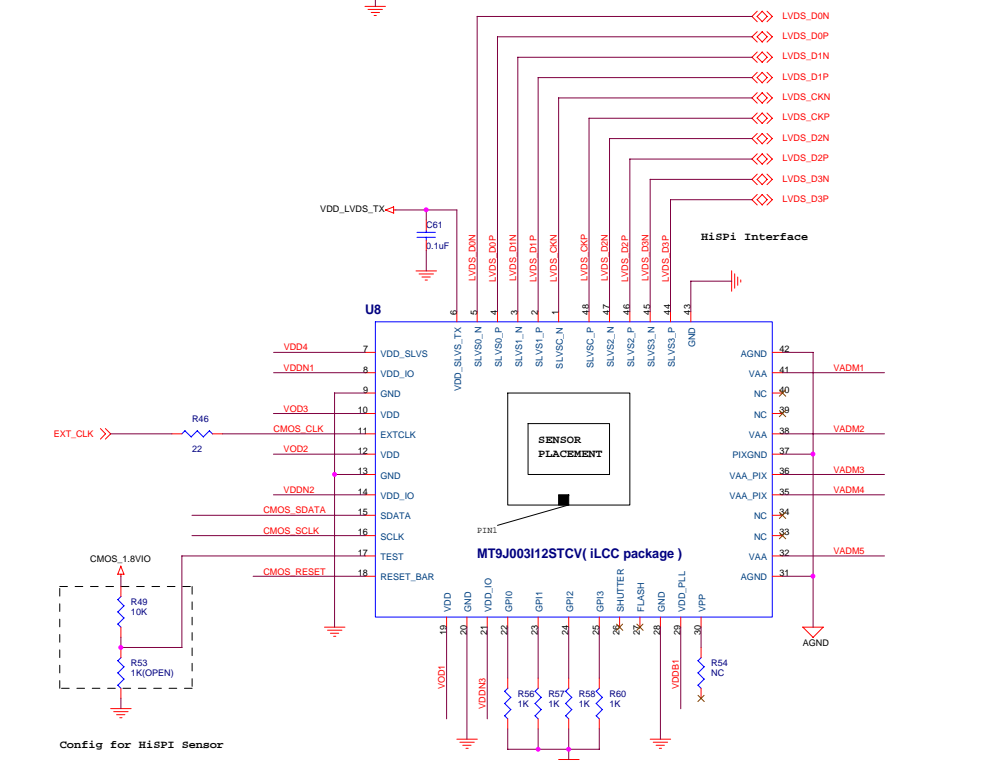
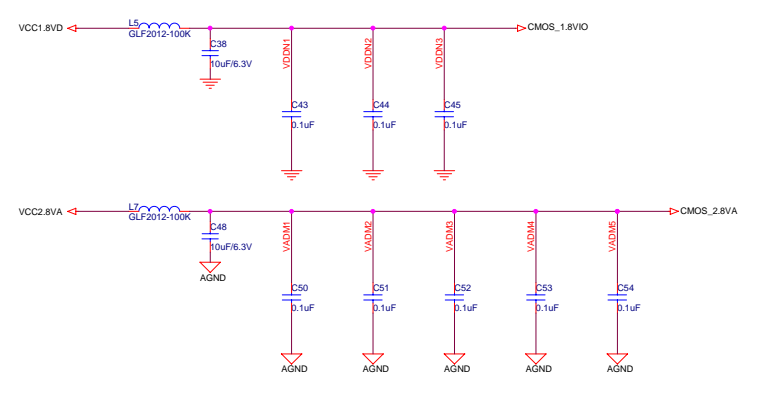
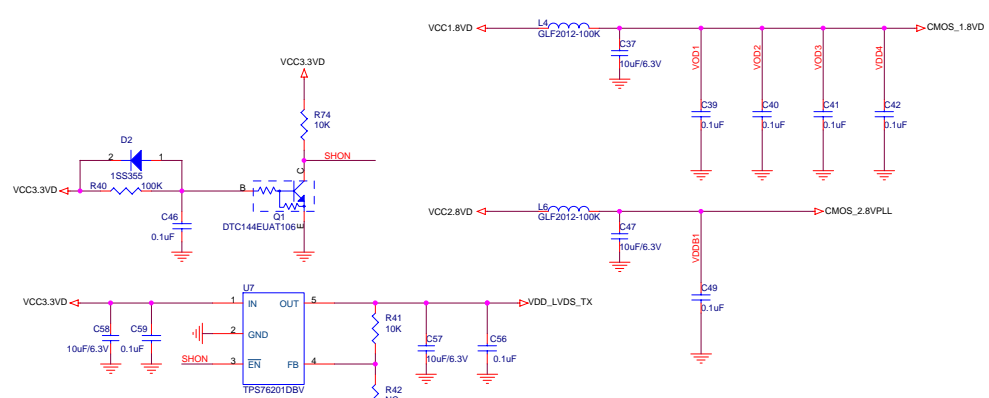

APPHOTO PROPRIETARY			
File SENSOR MAIN CIRCUIT			
Size	Document Number		Rev
C	APTINA MT9J003 10M CMOS SENSOR BOARD		0.3
Date	Friday, March 02, 2012	Sheet	3 of 3