

# WEBENCH<sup>®</sup> LED Architect

## 项目报告

项目 : 3493844/11 : Project ID 11  
 创建 : 2012-11-11 22:28:08.655  
 LED Architect with light output=9000.0

发布 WEBENCH LED Architect.

### 项目概览

总 BOM 成本 : \$0.00  
 整体大小 : 241,870 mm<sup>2</sup>  
 总 BOM 数量 : 554  
 整体效率 : 14.42%  
 Total Efficacy : 56.4 lumens / Watt  
 Total Power Dissipation (loss) : 0.0 Watts

### 设计输入 :

1. Vin 最大	253.0	最高输入电压
2. Vin 最小	187.0	最低输入电压
3. line_fsw	50.0	交流线路频率
4. color	cool white	LED Color
5. 源	AC	输入源类别
6. lightOutput	9000.0	Light Output in Lumen
7. maxHeatSinkLength	200.0	Max Heat Sink Length
8. maxHeatSinkWidth	50.0	Max Heat Sink Width
9. maxJunctionTemp	150.0	Max LED Junction Temperature
10. maxLEDStringVout	60.0	Max LED String Voltage
11. optfactor	3	Optimization factor to tune up the design
12. priceFactor	0	Price factor to tune up the design cost
13. 工作环境温度	60.0	环境温度

### Regulators

Main Driver NSID : LM3445MM/NOPB AC Line Voltage Compatible Buck LED driver; Driver Efficiency = 84.82%

### Drivers Electrical BOM

制造商	零件编号	数量	Budgetary Price	大小 (mm <sup>2</sup> )
ON Semiconductor	2N7002ET1G	7	\$0.21	158
Diodes Inc.	B160-13-F	14	\$0.84	523
Diodes Inc.	BAT54-7-F	7	\$0.21	158
Diodes Inc.	BC858C-7-F	7	\$0.21	158
Vishay-Semiconductor	BZX84C5V1-V-GS08	7	\$0.15	158
Kemet	C0603C224ZVACTU	7	\$0.07	71
TDK	C3216X7R2A105M	7	\$0.77	131
TDK	C3216X7R2J222K	7	\$0.35	131
Yageo America	CC0805KRX7R9BB221	7	\$0.07	91
Vishay-Dale	CRCW0402100RFKED	7	\$0.07	52
Vishay-Dale	CRCW040210K0FKED	7	\$0.07	52
Vishay-Dale	CRCW0402133KFKED	7	\$0.07	52
Vishay-Dale	CRCW04021R00FKED	7	\$0.07	52
Vishay-Dale	CRCW0402200KFKED	7	\$0.07	52
Vishay-Dale	CRCW0402280KFKED	7	\$0.07	52
Vishay-Dale	CRCW0402332RFKED	7	\$0.07	52
Vishay-Dale	CRCW040233K2FKED	7	\$0.07	52
Vishay-Dale	CRCW0402499RFKED	7	\$0.07	52
Vishay-Dale	CRCW040249K9FKED	14	\$0.14	105
Vishay-Dale	CRCW04024M75FKED	7	\$0.07	52
Vishay-Dale	CRCW04027K50FKED	7	\$0.07	52
Texas Instruments	CSD25302Q2	7	\$1.19	112
CUSTOM	CUSTOM	7	\$0.00	0
Panasonic	EEUED2W150	70	\$5.18	2,944
Nippon Chemi-Con	EMVA100ADA470ME55G	7	\$0.63	373
Panasonic	ERJ-1TNF1240U	7	\$0.91	303
Panasonic	ERJ-1TRQF1R6U	7	\$1.33	303
Panasonic	ERJ-8ENF1003V	7	\$0.07	131
Panasonic	ERJ-8ENF1004V	7	\$0.07	131

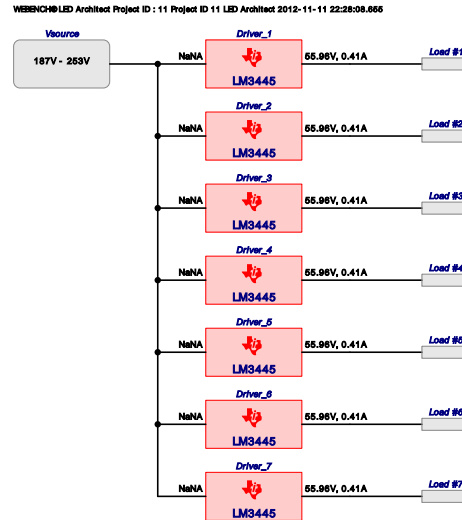

Panasonic	ERJ-8ENF2003V	7	\$0.07	131
Panasonic	ERJ-8ENF49R9V	7	\$0.07	131
Fairchild Semiconductor	FCD4N60TM	7	\$3.43	712
MuRata	GRM155C80G564KE19D	7	\$0.21	52
MuRata	GRM216R71H103KA01D	7	\$0.07	91
MuRata	GRM21BR71E104KA01L	14	\$0.14	182
MuRata	GRM43DR72J104KW01L	7	\$1.40	270
Diodes Inc.	HD04-T	7	\$0.84	435
Texas Instruments	LM3445MM/NOPB	7	\$5.04	242
Taiyo Yuden	LMK212BJ475KD-T	7	\$0.21	91
Diodes Inc.	MMBT4401-7-F	14	\$0.28	315
Fairchild Semiconductor	MMBT4403	7	\$0.21	158
ON Semiconductor	MMBZ5244BLT1G	7	\$0.21	158
Diodes Inc.	MURS160-13-F	7	\$0.77	309
Diodes Inc.	RS1G-13-F	28	\$1.96	1,046
ST Microelectronics	STD3NK80ZT4	7	\$4.20	712
Total		427	\$32.28	11,589

LED Array Solution BOM = LEDs + Heatsink

制造商	零件编号	数量	Cost	大小 (cm <sup>2</sup> )
Cree	XPCWHT-L1-R250-00A01	126	\$91.98	-
Aavid	60520	1	\$60.91	2,059
Total			\$152.89	2,059

## LED Array Solution

### LED Array

Light Output : 9000 lumens  
 Color : cool white  
 LED quantity : 126系列 = 18Parallel = 7  
 Total Vout : 56 Volts  
 Total Iload : 0.4 Amps  
 Total Light Output : 9000 lumens  
 Flux : 71 lumens  
 ThetaSA : 0.27 C / Watt  
 Junction Temp : 117 degrees  
 Operating Vf : 3.109 Volts  
 Operating Io : 0.407 Amps  
 效率 : 17%  
 Efficacy : 56.4 lumens / Watt  
 整体大小 : 205974.3 mm2  
 Total LED Cost : \$152.89  
 Max LED Vout : 60.0 Volts

### Selected LED



制造商 : Cree  
 零件编号 : XPCWHT-L1-R250-00A01  
 Vf : 3.2 V  
 Io : 0.35 A  
 Angle : 110.0 degree  
 PhiV : 87.4  
 Color Temperature : 6500.0 K  
 Color : cool white  
 Tj : 150.0 deg C  
 IfMin : 0.1 Amps  
 IfMax : 0.5 Amps  
 RJC : 12.0 deg C/Ohm  
 Isat : 0.0 Amps  
 Package mount : SMT  
 Footprint : 29.7 mm2

LED Load Array: For each color: cathode = 18, anode = 1, LED Quantity = 18  
 Total Drive Quantity = 7 Total LED Quantity = 126



### Heatsink

Length : 821.19 mm  
 Width : 250.82 mm  
 Height : 32.89 mm  
 Total Heatsink Footprint : 205974 mm2  
 Total Heatsink Cost : \$60.91

制造商 : Aavid  
 零件编号 : 60520  
 ThetaSA : 0.27 C/W

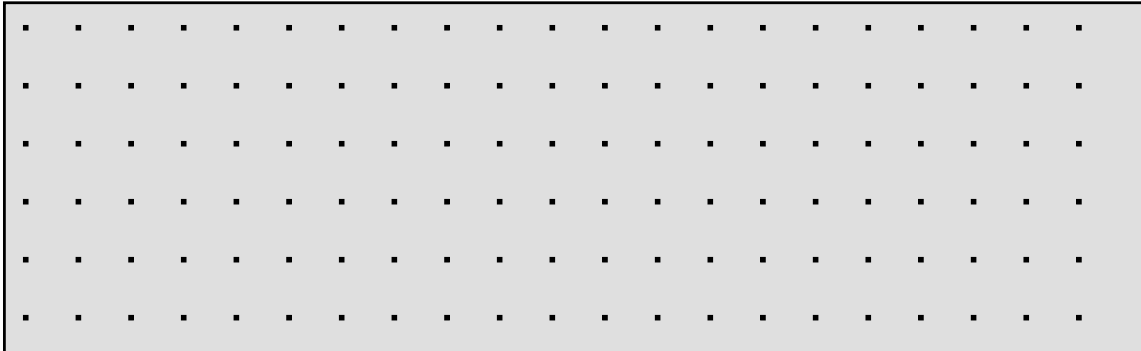

## Project Diagram

WEBENCH® LED Architect Project ID : 11 Project ID 11 LED Architect 2012- 11- 11 22:28:08.655

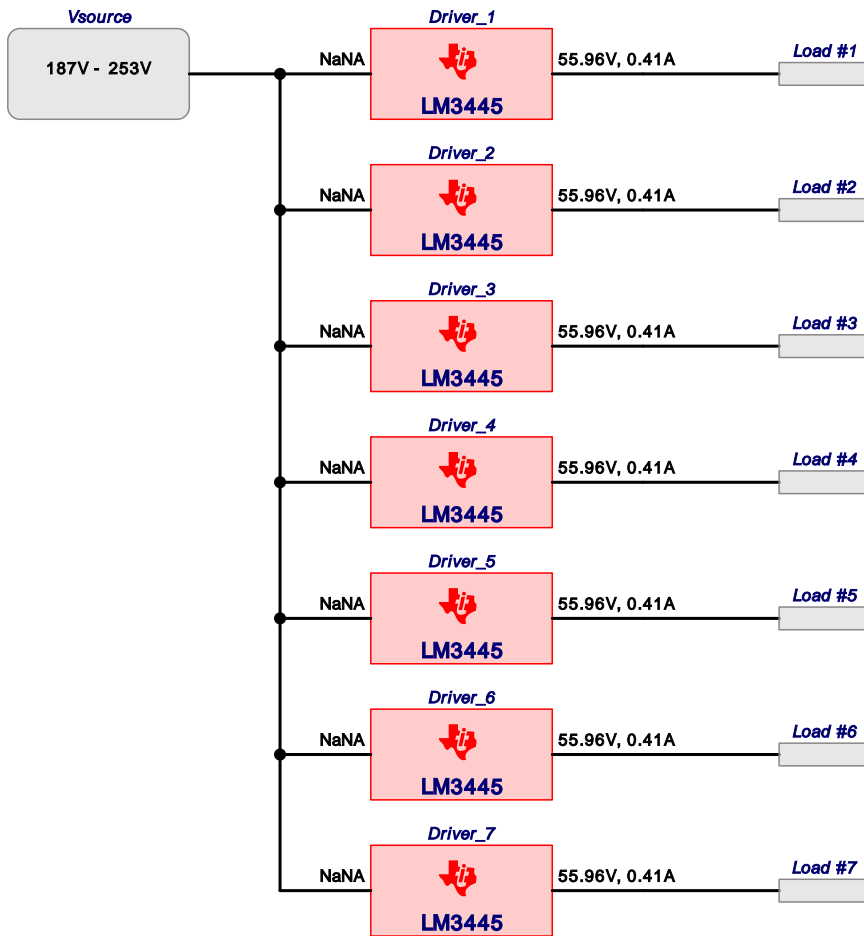



VinMin = 187.0V  
 VinMax = 253.0V  
 Vout = 55.96V  
 Iout = 0.41A

Device = LM3445MM/NOPB  
 Topology = Buck  
 创建 = 11/11/12 10:28:07 PM  
 BOM成本 = \$0.00  
 Total Pd = 0.0 W  
 大小 = 5,129.0 mm2  
 BOM 数量 = 79





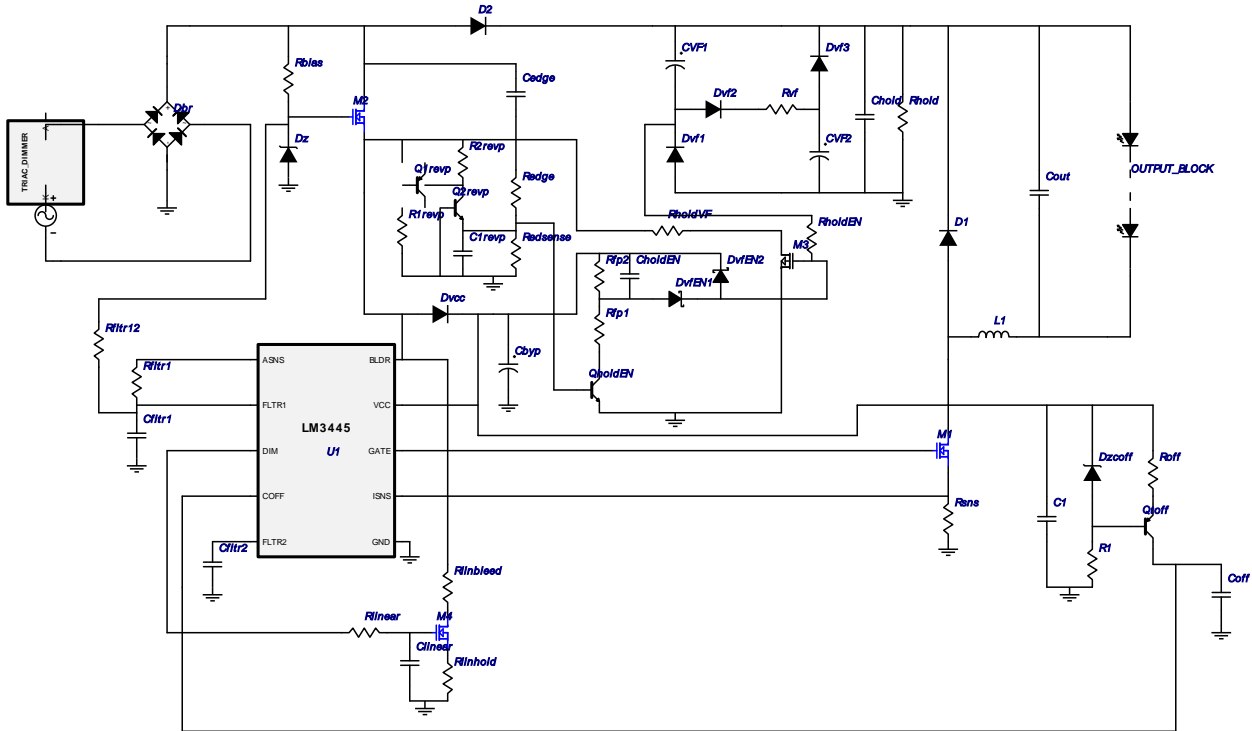

## WEBENCH® 设计报告

Design : 3493844/44 LM3445MM/NOPB  
 LM3445MM/NOPB 187.0V-253.0V to 62.86291283778736V @ 0.407A



## 电气材料清单

#	名称	制造商	零件编号	数量	Price	属性	大小
1.	C1	MuRata	GRM21BR71E104KA01L Series= X7R	1	\$0.01	Cap= 100.0 nF VDC= 25.0 V IRMS= 0.0 A	0805 13mm2
2.	C1revp	MuRata	GRM216R71H103KA01D Series= X7R	1	\$0.01	Cap= 10.0 nF VDC= 50.0 V IRMS= 0.0 A	0805 13mm2
3.	CVF1	Panasonic	EEUED2W150 Series= 286	5	\$0.37	Cap= 15.0 µF ESR= 1.91 Ohm VDC= 450.0 V IRMS= 560.0 mA	CAPPR5-12.5X25 210mm2
4.	CVF2	Panasonic	EEUED2W150 Series= 286	5	\$0.37	Cap= 15.0 µF ESR= 1.91 Ohm VDC= 450.0 V IRMS= 560.0 mA	CAPPR5-12.5X25 210mm2
5.	Cbyp	Nippon Chemi-Con	EMVA100ADA470ME55G Series= MVA	1	\$0.09	Cap= 47.0 µF VDC= 10.0 V IRMS= 44.0 mA	CAPSMT_62_E55 53mm2
6.	Cedge	TDK	C3216X7R2J222K Series= X7R	1	\$0.05	Cap= 2.2 nF ESR= 151.0 mOhm VDC= 630.0 V IRMS= 0.0 A	1206 19mm2

#	名称	制造商	零件编号	数量	Price	属性	大小
7.	Cftr1	MuRata	GRM155C80G564KE19D Series= 379	1	\$0.03	Cap= 560.0 nF VDC= 4.0 V IRMS= 0.0 A	 0402 8mm2
8.	Cftr2	MuRata	GRM21BR71E104KA01L Series= X7R	1	\$0.01	Cap= 100.0 nF VDC= 25.0 V IRMS= 0.0 A	 0805 13mm2
9.	Chold	MuRata	GRM43DR72J104KW01L Series= X7R	1	\$0.20	Cap= 100.0 nF VDC= 630.0 V IRMS= 0.0 A	 1812 39mm2
10.	CholdEN	Taiyo Yuden	LMK212BJ475KD-T Series= X5R	1	\$0.03	Cap= 4.7 µF VDC= 10.0 V IRMS= 0.0 A	 0805 13mm2
11.	Clinear	Kemet	C0603C224Z4VACTU Series= Y5V	1	\$0.01	Cap= 220.0 nF VDC= 16.0 V IRMS= 0.0 A	 0603 10mm2
12.	Coff	Yageo America	CC0805KRX7R9BB221 Series= X7R	1	\$0.01	Cap= 220.0 pF VDC= 50.0 V IRMS= 0.0 A	 0805 13mm2
13.	Cout	TDK	C3216X7R2A105M Series= 285	1	\$0.11	Cap= 1.0 µF ESR= 6.0 mOhm VDC= 100.0 V IRMS= 4.5 A	 1206 19mm2
14.	D1	Diodes Inc.	MURS160-13-F	1	\$0.11	VF@Io= 1.25 V VRRM= 600.0 V	 SMB 44mm2
15.	D2	Diodes Inc.	RS1G-13-F	1	\$0.07	VF@Io= 1.3 V VRRM= 400.0 V	 SMA 37mm2
16.	D_LED	Cree	XPCWHT-L1-R250-00A01	18	\$0.73	LED	 xlampxpc 30mm2
17.	Dbr	Diodes Inc.	HD04-T	1	\$0.12	VF@Io= 1.0 V VRRM= 400.0 V	 MiniDIP 62mm2
18.	Dvcc	Diodes Inc.	BAT54-7-F	1	\$0.03	VF@Io= 650.0 mV VRRM= 30.0 V	 SOT-23 22mm2
19.	Dvf1	Diodes Inc.	RS1G-13-F	1	\$0.07	VF@Io= 1.3 V VRRM= 400.0 V	 SMA 37mm2
20.	Dvf2	Diodes Inc.	RS1G-13-F	1	\$0.07	VF@Io= 1.3 V VRRM= 400.0 V	 SMA 37mm2
21.	Dvf3	Diodes Inc.	RS1G-13-F	1	\$0.07	VF@Io= 1.3 V VRRM= 400.0 V	 SMA 37mm2
22.	DvfEN1	Diodes Inc.	B160-13-F	1	\$0.06	VF@Io= 700.0 mV VRRM= 60.0 V	 SMA 37mm2
23.	DvfEN2	Diodes Inc.	B160-13-F	1	\$0.06	VF@Io= 700.0 mV VRRM= 60.0 V	 SMA 37mm2
24.	Dz	ON Semiconductor	MMBZ5244BLT1G	1	\$0.03	Zener	 SOT-23 22mm2
25.	Dzcoff	Vishay-Semiconductor	BZX84C5V1-V-GS08	1	\$0.02	Zener	 SOT-23 22mm2
26.	L1	CUSTOM	CUSTOM	1	\$0.00	L= 1.178 mH DCR= 687.469 mOhm	CUSTOM 0mm2
27.	M1	Fairchild Semiconductor	FCD4N60TM	1	\$0.49	VdsMax= 600.0 V IdsMax= 3.9 Amps	 DPAK 102mm2

#	名称	制造商	零件编号	数量	Price	属性	大小
28.	M2	ST Microelectronics	STD3NK80ZT4	1	\$0.60	VdsMax= 800.0 V IdsMax= 2.5 Amps	 DPAK 102mm2
29.	M3	Texas Instruments	CSD25302Q2	1	\$0.17	VdsMax= -20.0 V IdsMax= -5.0 Amps	 TRANS_NexFET_Q2 16mm2
30.	M4	ON Semiconductor	2N7002ET1G	1	\$0.03	VdsMax= 60.0 V IdsMax= 260.0 mAmps	 SOT-23 22mm2
31.	Q1revp	Diodes Inc.	BC858C-7-F	1	\$0.03	Bipolar Transistor	 SOT-23 22mm2
32.	Q2revp	Diodes Inc.	MMBT4401-7-F	1	\$0.02	Bipolar Transistor	 SOT-23 22mm2
33.	QholdEN	Diodes Inc.	MMBT4401-7-F	1	\$0.02	Bipolar Transistor	 SOT-23 22mm2
34.	Qtoff	Fairchild Semiconductor	MMBT4403	1	\$0.03	Bipolar Transistor	 SOT-23 22mm2
35.	R1	Vishay-Dale	CRCW040233K2FKED Series= CRCW..e3	1	\$0.01	Res= 33.2 kOhm Power= 63.0 mW Tolerance= 1.0%	 0402 8mm2
36.	R1revp	Vishay-Dale	CRCW0402499RFKED Series= CRCW..e3	1	\$0.01	Res= 499.0 Ohm Power= 63.0 mW Tolerance= 1.0%	 0402 8mm2
37.	R2revp	Vishay-Dale	CRCW040249K9FKED Series= CRCW..e3	1	\$0.01	Res= 49.9 kOhm Power= 63.0 mW Tolerance= 1.0%	 0402 8mm2
38.	Rbias	Panasonic	ERJ-8ENF1003V Series= ERJ-8E	1	\$0.01	Res= 100.0 kOhm Power= 250.0 mW Tolerance= 1.0%	 1206 19mm2
39.	Redge	Panasonic	ERJ-8ENF2003V Series= ERJ-8E	1	\$0.01	Res= 200.0 kOhm Power= 250.0 mW Tolerance= 1.0%	 1206 19mm2
40.	Redsense	Vishay-Dale	CRCW04027K50FKED Series= CRCW..e3	1	\$0.01	Res= 7.5 kOhm Power= 63.0 mW Tolerance= 1.0%	 0402 8mm2
41.	Rftr1	Vishay-Dale	CRCW0402280KFKED Series= CRCW..e3	1	\$0.01	Res= 280.0 kOhm Power= 63.0 mW Tolerance= 1.0%	 0402 8mm2
42.	Rftr12	Vishay-Dale	CRCW04024M75FKED Series= CRCW..e3	1	\$0.01	Res= 4.75 MOhm Power= 63.0 mW Tolerance= 1.0%	 0402 8mm2
43.	Rfp1	Vishay-Dale	CRCW0402100RFKED Series= CRCW..e3	1	\$0.01	Res= 100.0 Ohm Power= 63.0 mW Tolerance= 1.0%	 0402 8mm2
44.	Rfp2	Vishay-Dale	CRCW040210K0FKED Series= CRCW..e3	1	\$0.01	Res= 10.0 kOhm Power= 63.0 mW Tolerance= 1.0%	 0402 8mm2
45.	Rhold	Panasonic	ERJ-8ENF1004V Series= ERJ-8E	1	\$0.01	Res= 1000.0 kOhm Power= 250.0 mW Tolerance= 1.0%	 1206 19mm2
46.	RholdEN	Vishay-Dale	CRCW0402200KFKED Series= CRCW..e3	1	\$0.01	Res= 200.0 kOhm Power= 63.0 mW Tolerance= 1.0%	 0402 8mm2
47.	RholdVF	Panasonic	ERJ-1TNF1240U Series= 1118	1	\$0.13	Res= 124.0 Ohm Power= 1.0 W Tolerance= 1.0%	 2512 43mm2

#	名称	制造商	零件编号	数量	Price	属性	大小
48.	Rlinbleed	Vishay-Dale	CRCW0402332RFKED Series= CRCW..e3	1	\$0.01	Res= 332.0 Ohm Power= 63.0 mW Tolerance= 1.0%	 0402 8mm2
49.	Rlinear	Vishay-Dale	CRCW040249K9FKED Series= CRCW..e3	1	\$0.01	Res= 49.9 kOhm Power= 63.0 mW Tolerance= 1.0%	 0402 8mm2
50.	Rlinhold	Panasonic	ERJ-8ENF49R9V Series= ERJ-8E	1	\$0.01	Res= 49.9 Ohm Power= 250.0 mW Tolerance= 1.0%	 1206 19mm2
51.	Roff	Vishay-Dale	CRCW0402133KFKED Series= CRCW..e3	1	\$0.01	Res= 133.0 kOhm Power= 63.0 mW Tolerance= 1.0%	 0402 8mm2
52.	Rsns	Panasonic	ERJ-1TRQF1R6U Series= ?	1	\$0.19	Res= 1.6 Ohm Power= 1.0 W Tolerance= 1.0%	 2512 43mm2
53.	Rvf	Vishay-Dale	CRCW04021R00FKED Series= CRCW..e3	1	\$0.01	Res= 1.0 Ohm Power= 63.0 mW Tolerance= 1.0%	 0402 8mm2
54.	U1	Texas Instruments	LM3445MM/NOPB	1	\$0.72	Switcher	 MUB10A 34mm2

## 工作数值

#	名称	数值	类别	说明
1.	ILED Avg	452.645 mA	Current	针对交流线路期间的每LED平均电流
2.	平均LED 纹波电流	330.7 $\mu$ A	Current	在交流线路期间的平均 LED 纹波电流
3.	平均的整流输入电压	241.998 V	General	针对交流线路时段的平均整流电压
4.	BOM 数量	79.0	General	Total Design BOM count
5.	大小	5.129 k mm2	General	BOM组件的总所占面积
6.	总 BOM	\$0.0	General	Total BOM Cost
7.	平均泄漏 FET Tj	717.356 degC	Op_Point	在交流线路期间的泄漏 MOSFET 平均接点温度
8.	Avg M1 FET Tj	98.355 degC	Op_Point	在交流线路期间的M1 MOSFET 平均接点温度
9.	平均占空比	28.476 %	Op_point	在交流线路期间的平均占空比
10.	平均效率	77.748 %	Op_point	在交流线路期间的平均效率
11.	平均频率	1.199 M Hz	Op_point	在交流线路期间的平均开关频率
12.	Avg IC Tj	85.934 degC	Op_point	针对交流线路期间的平均电路接点温度
13.	VIN_OP	253.0 V	Op_point	交流输入均方根电压
14.	平均泄漏 FET Pd	6.574 W	Power	在交流线路期间于泄漏FET内的平均功率耗散
15.	平均桥二极管 Pd	170.68 m W	Power	桥二极管在交流线路期间的平均功率耗散
16.	平均 Cout Pd	518.724 n W	Power	输出电容器在交流线路期间的平均功率耗散
17.	平均的二极管1 Pd	218.475 m W	Power	D1在交流线路期间的平均功率耗散
18.	平均二极管2 Pd	96.405 m W	Power	D1在交流线路期间的平均功率耗散
19.	平均 FET Pd	435.124 m W	Power	在交流线路期间于开关FET内的平均功率耗散
20.	Avg IC Pd	214.33 m W	Power	在交流线路期间于电路内的平均功率耗散
21.	Avg L pd	176.068 m W	Power	在交流线路期间的平均电感器功率耗散
22.	Avg Rblid Pd	106.694 m W	Power	在交流线路期间于泄漏电阻器内的平均功率耗散
23.	Avg Rsns Pd	28.515 m W	Power	在交流线路期间于电流限幅电阻器内的平均功率耗散
24.	平均填谷电容器功率耗散	44.229 m W	Power	填谷电容器在交流线路期间的平均功率耗散
25.	平均填谷二极管功率耗散	574.866 m W	Power	填谷二极管在交流线路期间的平均功率耗散
26.	整体 Pd	0.0 W	Power	总功率耗散
27.	平均线性保持电流	0.0 A	Unknown	在交流线路期间的平均线性保持电流
28.	平均填谷保持电流	10.161 m A	Unknown	在交流线路期间的平均填谷保持电流
29.	光度百分比	75.0 %	Unknown	调光后的光度百分比

## 设计输入

#	名称	数值	说明
1.	输出电流	407.0 mA	最大输出电流
2.	Iout1	407.0 mAmps	Output Current #1
3.	Vin 最大	253.0 V	最高输入电压
4.	Vin 最小	187.0 V	最低输入电压
5.	输出电压:	55.958 V	输出电压
6.	Vout1	55.958 Volt	Output Voltage #1
7.	应用	LED_DRIVER	LED 应用
8.	base_pn	LM3445	美国国家半导体的产品编号
9.	LED_Architect	Y	LED Architect Project
10.	ledparallel	1.0	并联的LED数量



#	名称	数值	说明
11.	LED 零件编号	XPCWHT-L1-R250-00A01	LED 零件编号
12.	ledseries	18.0	串联的LED数量
13.	line_fsw	50.0	交流线路频率
14.	源	AC	输入源类别
15.	工作环境温度	60.0 degC	环境温度

## 设计协助

1. LM3445 Product Folder : <http://www.ti.com/product/lm3445> : contains the data sheet and other resources.

Texas Instruments' WEBENCH simulation tools attempt to recreate the performance of a substantially equivalent physical implementation of the design. Simulations are created using Texas Instruments' published specifications as well as the published specifications of other device manufacturers. While Texas Instruments does update this information periodically, this information may not be current at the time the simulation is built. Texas Instruments does not warrant the accuracy or completeness of the specifications or any information contained therein. Texas Instruments does not warrant that any designs or recommended parts will meet the specifications you entered, will be suitable for your application or fit for any particular purpose, or will operate as shown in the simulation in a physical implementation. Texas Instruments does not warrant that the designs are production worthy.

**You should completely validate and test your design implementation to confirm the system functionality for your application prior to production.**

Use of Texas Instruments' WEBENCH simulation tools is subject to [Texas Instruments' Site Terms and Conditions of Use](#). Prototype boards based on WEBENCH created designs are provided AS IS without warranty of any kind for evaluation and testing purposes and are subject to the terms of the [Evaluation License Agreement](#).