

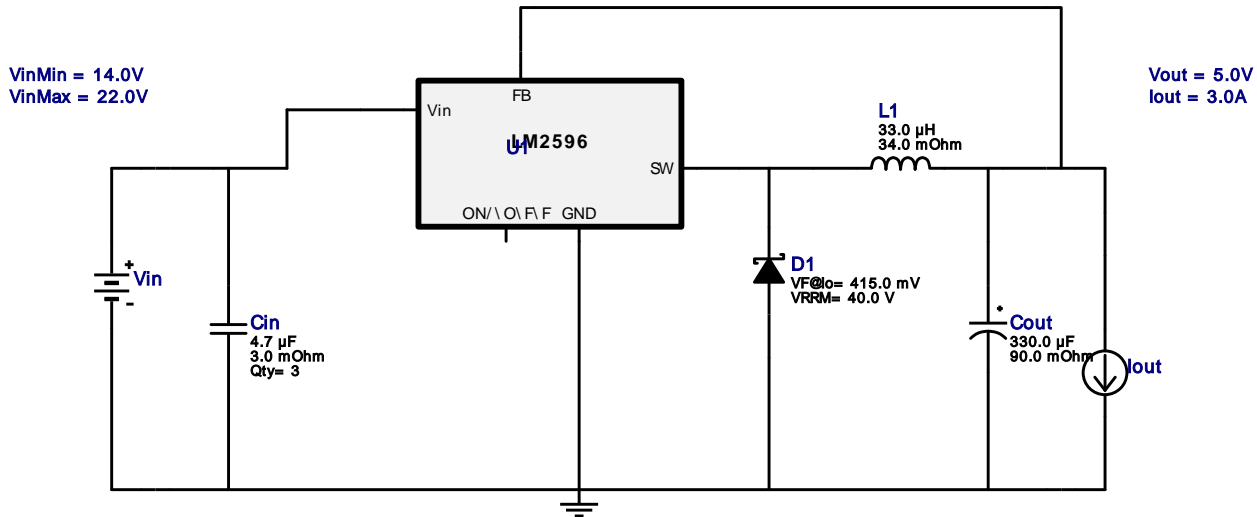



WEBENCH[®] Design Report

 Design : 1913858/1263 LM2596SX-5.0/NOPB
 LM2596SX-5.0/NOPB 14.0V-22.0V to 5.0V @ 3.0A

Electrical BOM

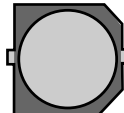
| # | Name | Manufacturer | Part Number | Properties | Qty | Price | Footprint |
|----|------|-------------------|-----------------------------------|--|-----|--------|--|
| 1. | Cin | MuRata | GRM31CR71H475KA12L Series= X7R | Cap= 4.7 µF ESR= 3.0 mOhm VDC= 50.0 V IRMS= 4.98 A | 3 | \$0.10 |  1206 11mm ² |
| 2. | Cout | Nichicon | UUD1V331MNL1GS Series= uD | Cap= 330.0 µF ESR= 90.0 mOhm VDC= 35.0 V IRMS= 670.0 mA | 1 | \$0.25 |  SM_RADIAL_10BMM 160mm ² |
| 3. | D1 | ON Semiconductor | MBRA340T3G | VF@Io= 415.0 mV VRRM= 40.0 V | 1 | \$0.19 |  SMA 37mm ² |
| 4. | L1 | Coilcraft | MSS1210-333MEB | L= 33.0 µH DCR= 34.0 mOhm | 1 | \$0.81 |  MSS1210 204mm ² |
| 5. | U1 | Texas Instruments | LM2596SX-5.0/NOPB | Switcher | 1 | \$1.80 |  TS5B 199mm ² |

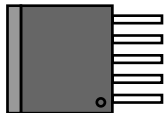
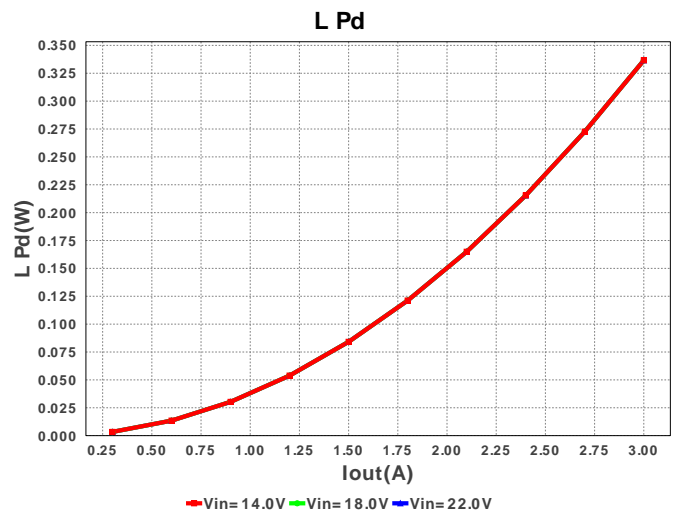
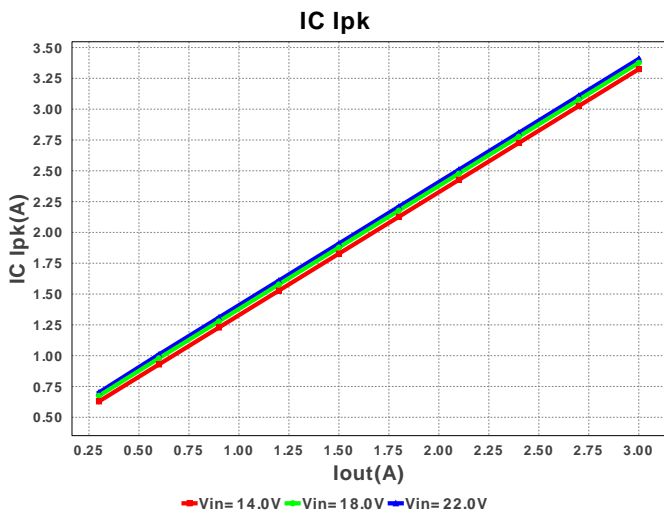
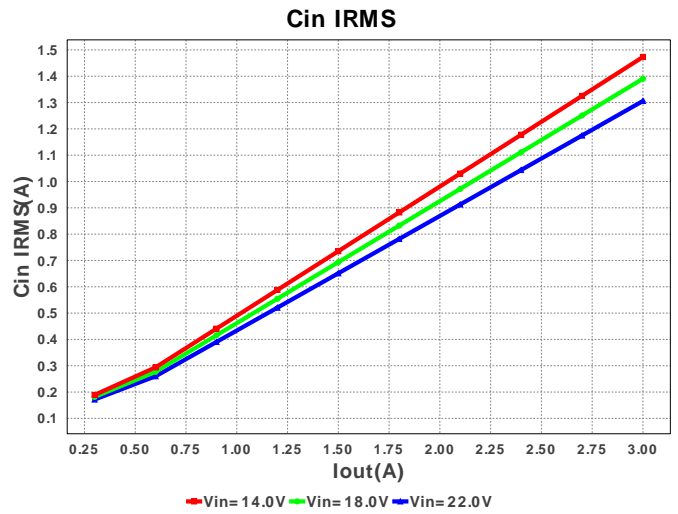
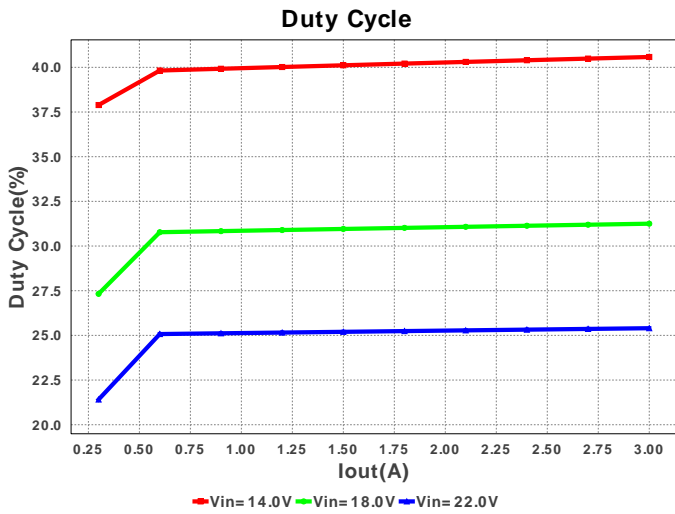
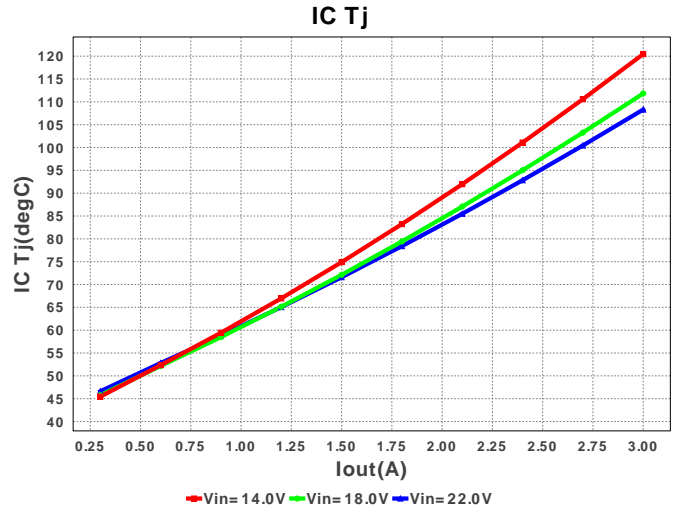
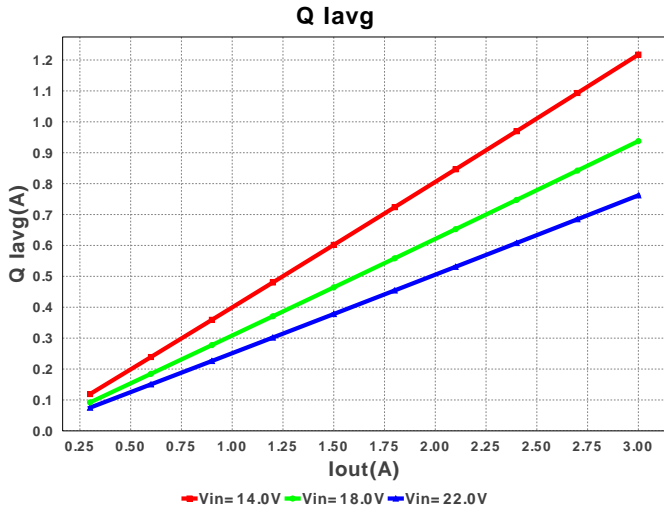
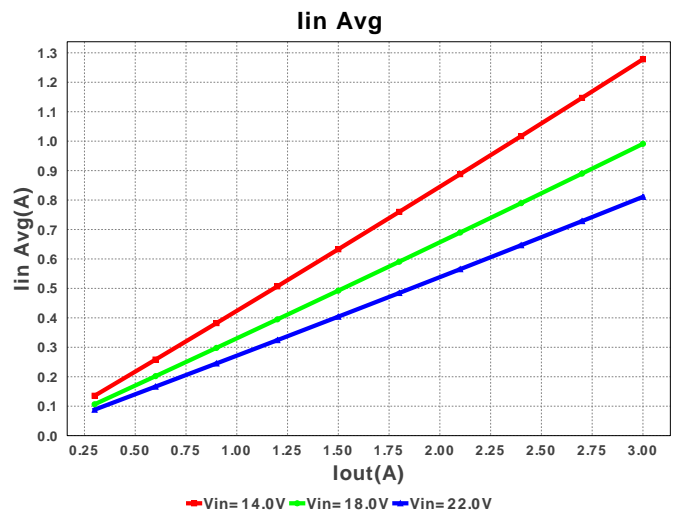
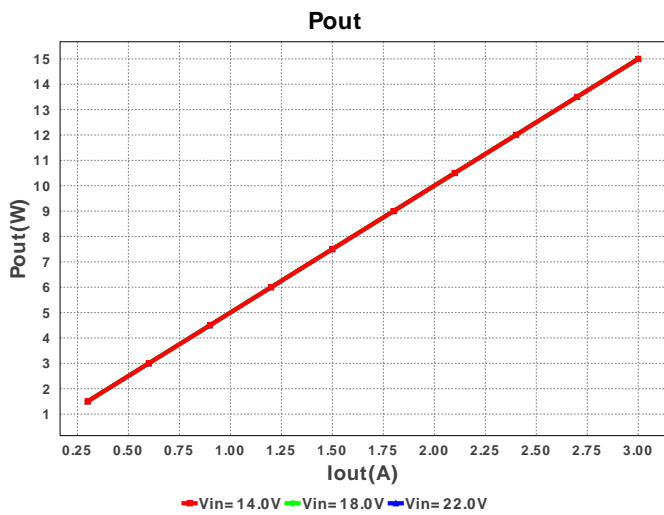
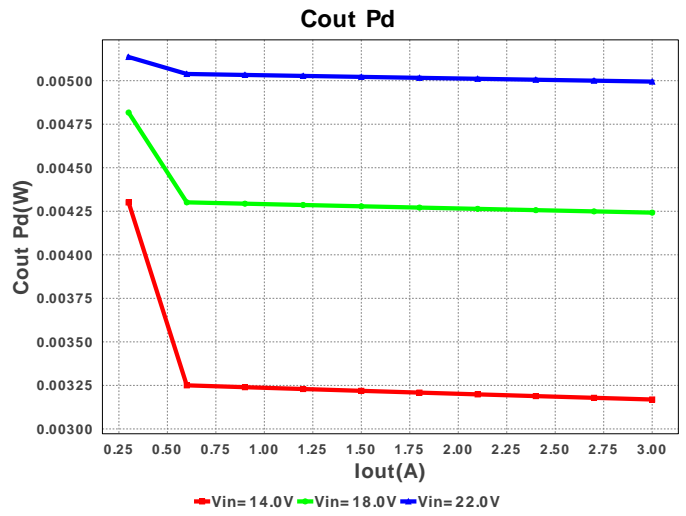
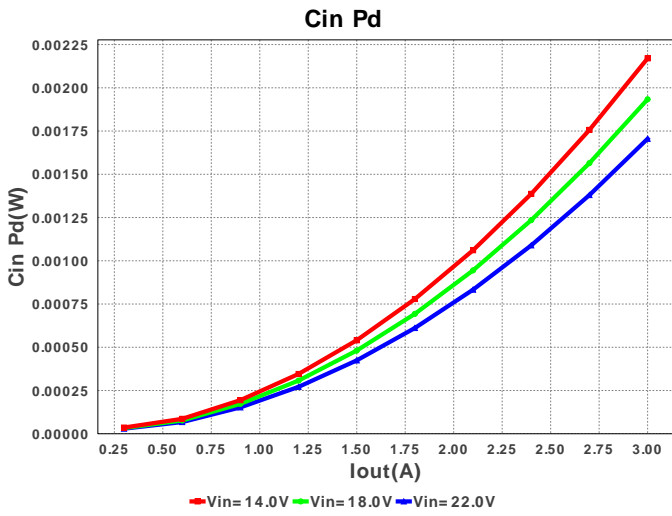
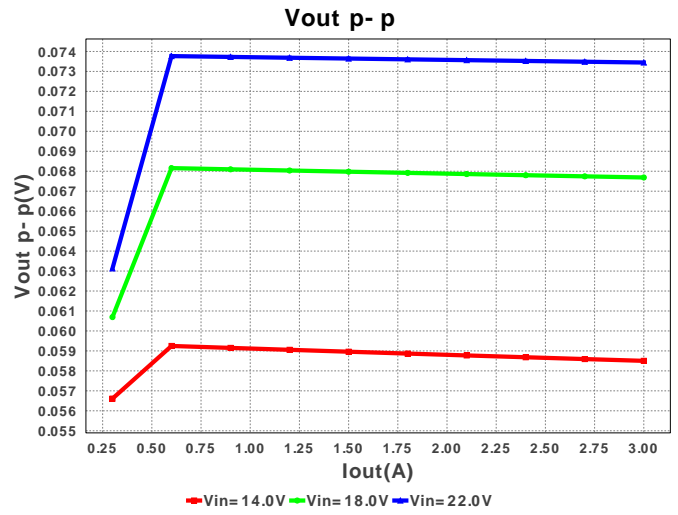
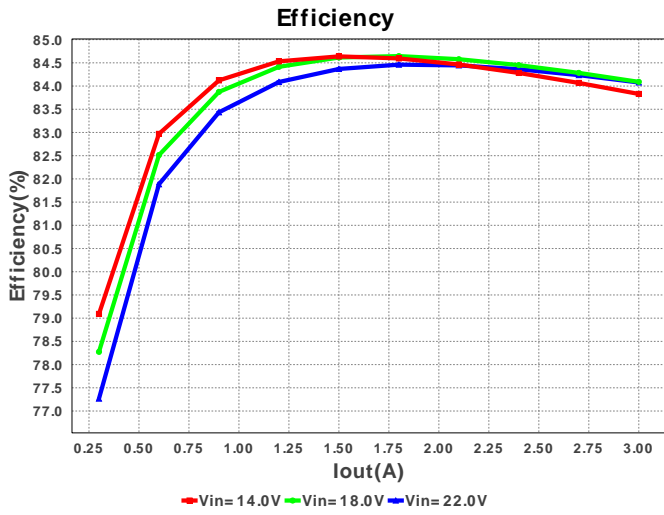

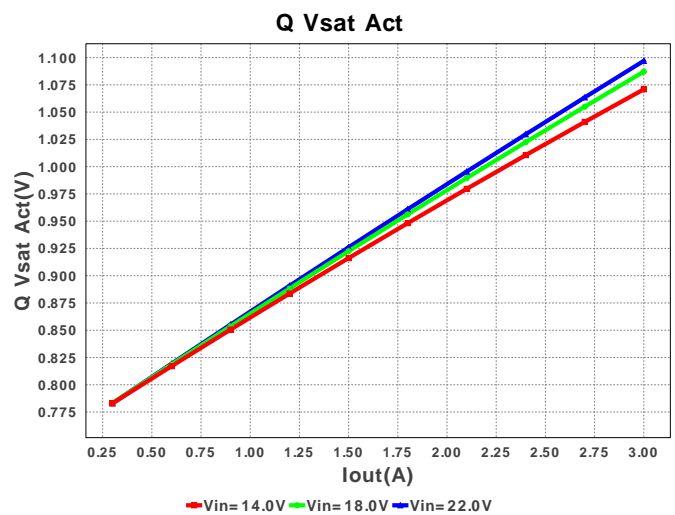
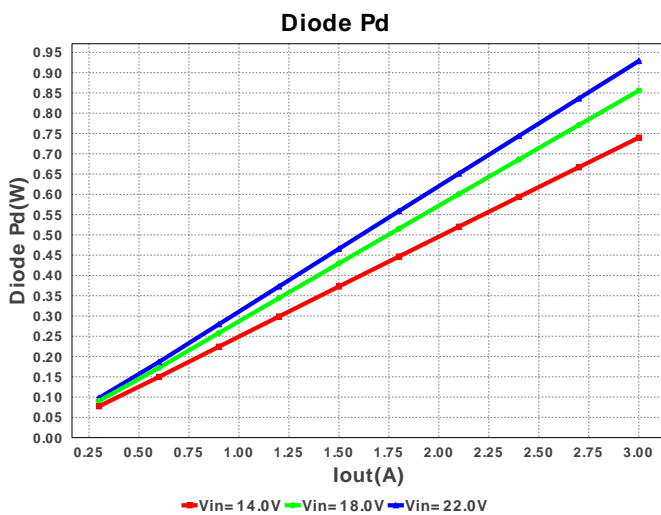
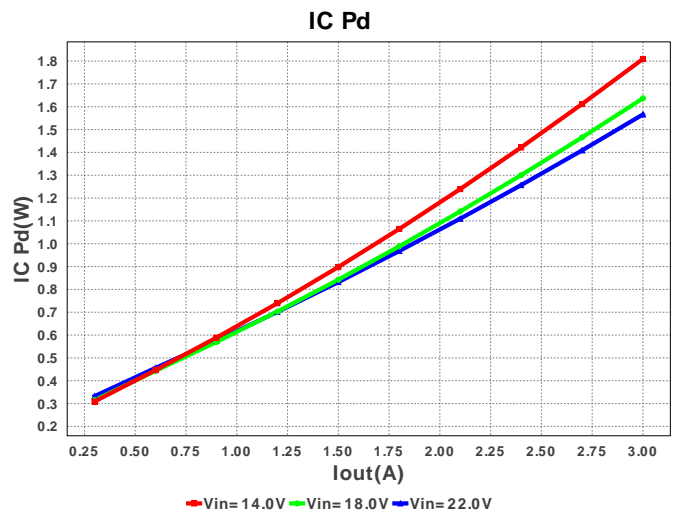
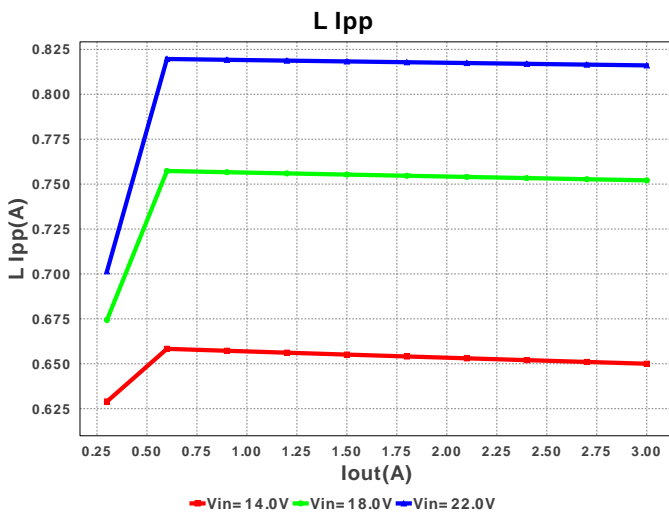
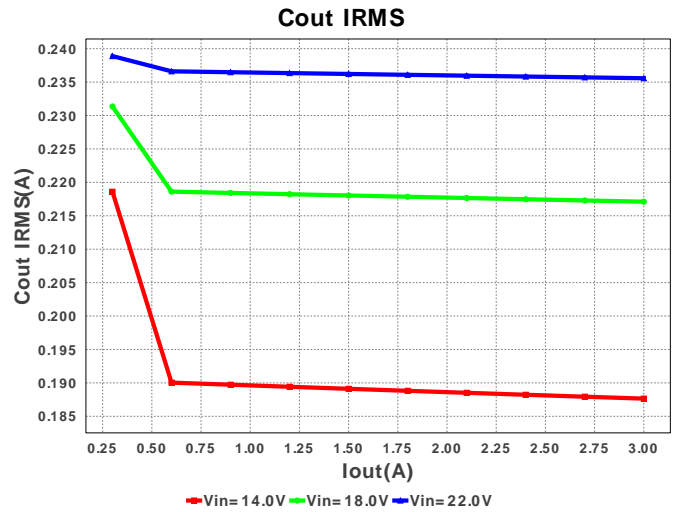
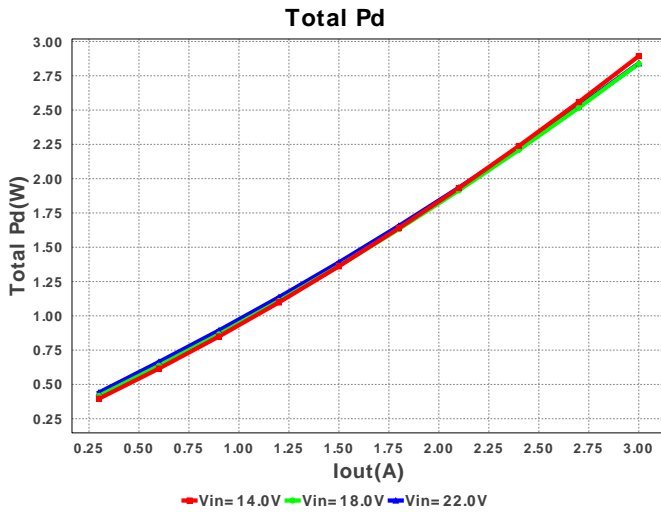



Operating Values

| # | Name | Value | Category | Description |
|-----|--------------|------------|----------|---|
| 1. | Cin IRMS | 1.306 A | Current | Input capacitor RMS ripple current |
| 2. | Cout IRMS | 235.578 mA | Current | Output capacitor RMS ripple current |
| 3. | IC Ipk | 3.408 A | Current | Peak switch current in IC |
| 4. | Iin Avg | 811.28 mA | Current | Average input current |
| 5. | L Ipp | 816.067 mA | Current | Peak-to-peak inductor ripple current |
| 6. | Q Iavg | 762.031 mA | Current | Q Iavg |
| 7. | BOM Count | 7 | General | Total Design BOM count |
| 8. | FootPrint | 633.0 mm2 | General | Total Foot Print Area of BOM components |
| 9. | Frequency | 150.0 kHz | General | Switching frequency |
| 10. | IC Tolerance | 0.0 V | General | IC Feedback Tolerance |
| 11. | Pout | 15.0 W | General | Total output power |

| # | Name | Value | Category | Description |
|-----|------------|--------------|----------|---|
| 12. | Q Vsat Act | 1.097 V | General | Q Vsat |
| 13. | Total BOM | \$3.34 | General | Total BOM Cost |
| 14. | Cross Freq | 22.909 kHz | Op_point | Bode plot crossover frequency |
| 15. | Duty Cycle | 25.401 % | Op_point | Duty cycle |
| 16. | Efficiency | 84.042 % | Op_point | Steady state efficiency |
| 17. | IC Tj | 108.308 degC | Op_point | IC junction temperature |
| 18. | ICThetaJA | 50.0 degC/W | Op_point | IC junction-to-ambient thermal resistance |
| 19. | IOUT_OP | 3.0 A | Op_point | Iout operating point |
| 20. | Phase Marg | 75.579 deg | Op_point | Bode Plot Phase Margin |
| 21. | VIN_OP | 22.0 V | Op_point | Vin operating point |
| 22. | Vout p-p | 73.446 mV | Op_point | Peak-to-peak output ripple voltage |
| 23. | Cin Pd | 1.705 mW | Power | Input capacitor power dissipation |
| 24. | Cout Pd | 4.995 mW | Power | Output capacitor power dissipation |
| 25. | Diode Pd | 928.757 mW | Power | Diode power dissipation |
| 26. | IC Pd | 1.566 W | Power | IC power dissipation |
| 27. | L Pd | 336.6 mW | Power | Inductor power dissipation |
| 28. | Total Pd | 2.848 W | Power | Total Power Dissipation |

Design Inputs

| # | Name | Value | Description |
|----|---------|-----------|------------------------|
| 1. | Iout | 3.0 A | Maximum Output Current |
| 2. | Iout1 | 3.0 Amps | Output Current #1 |
| 3. | VinMax | 22.0 V | Maximum input voltage |
| 4. | VinMin | 14.0 V | Minimum input voltage |
| 5. | Vout | 5.0 V | Output Voltage |
| 6. | Vout1 | 5.0 Volt | Output Voltage #1 |
| 7. | base_pn | LM2596 | Base Product Number |
| 8. | source | DC | Input Source Type |
| 9. | Ta | 30.0 degC | Ambient temperature |

Design Assistance

1. **LM2596** Product Folder : <http://www.ti.com/product/lm2596> : contains the data sheet and other resources.

Texas Instruments' WEBENCH simulation tools attempt to recreate the performance of a substantially equivalent physical implementation of the design. Simulations are created using Texas Instruments' published specifications as well as the published specifications of other device manufacturers. While Texas Instruments does update this information periodically, this information may not be current at the time the simulation is built. Texas Instruments does not warrant the accuracy or completeness of the specifications or any information contained therein. Texas Instruments does not warrant that any designs or recommended parts will meet the specifications you entered, will be suitable for your application or fit for any particular purpose, or will operate as shown in the simulation in a physical implementation. Texas Instruments does not warrant that the designs are production worthy.

You should completely validate and test your design implementation to confirm the system functionality for your application prior to production.

Use of Texas Instruments' WEBENCH simulation tools is subject to [Texas Instruments' Site Terms and Conditions of Use](#). Prototype boards based on WEBENCH created designs are provided AS IS without warranty of any kind for evaluation and testing purposes and are subject to the terms of the [Evaluation License Agreement](#).