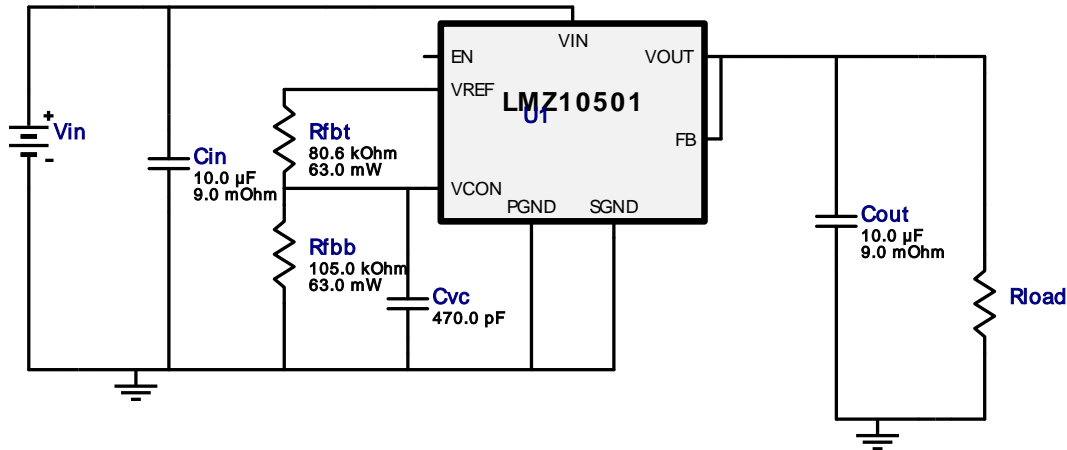

**WEBENCH® Design Report**

 Design : 1582560/515 LMZ10501SILR  
 LMZ10501SILR 5.0V-5.0V to 3.3V @ 1.0A

 VinMin = 5.0V  
 VinMax = 5.0V

 Vout = 3.3V  
 Iout = 1.0A

**Electrical BOM**

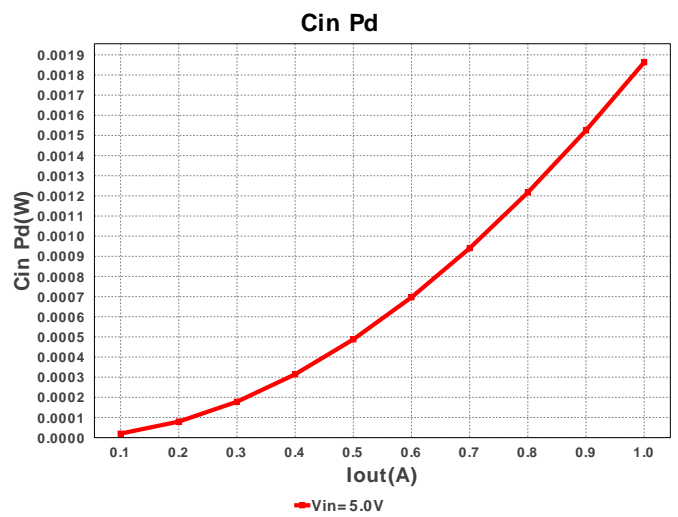
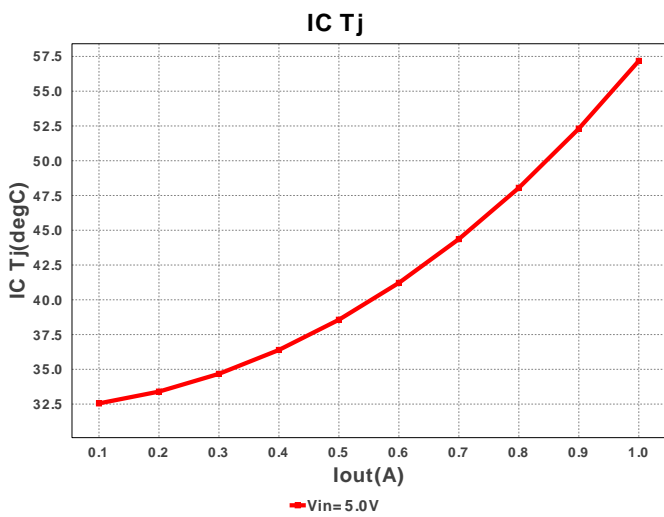
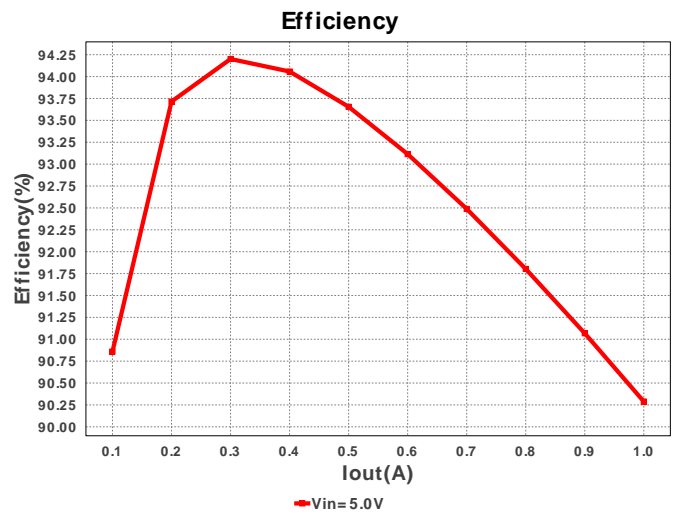
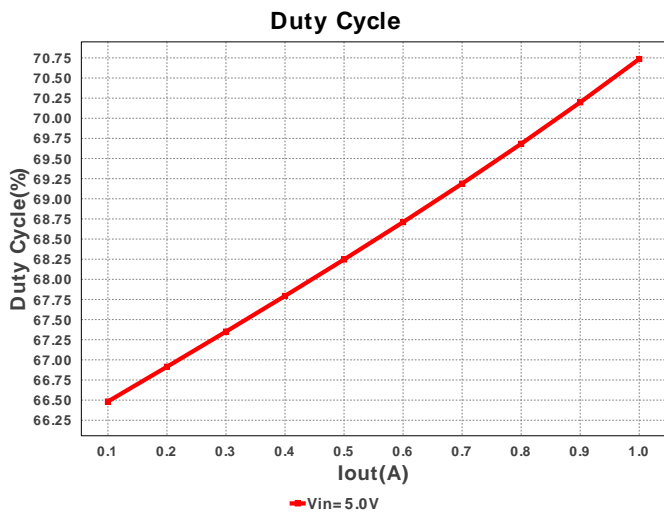
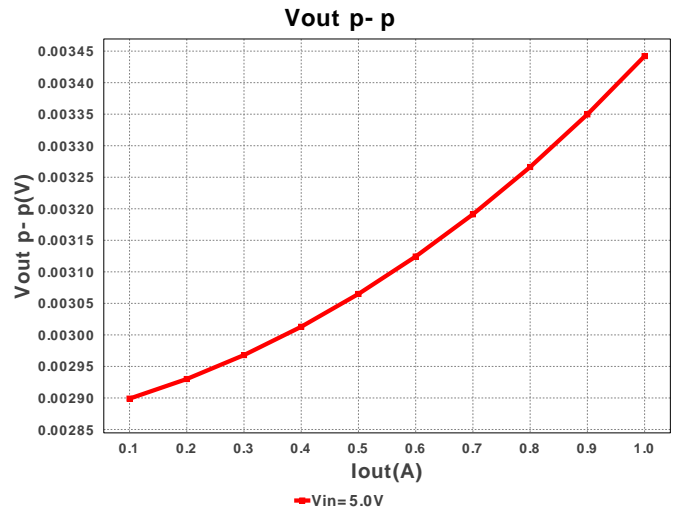
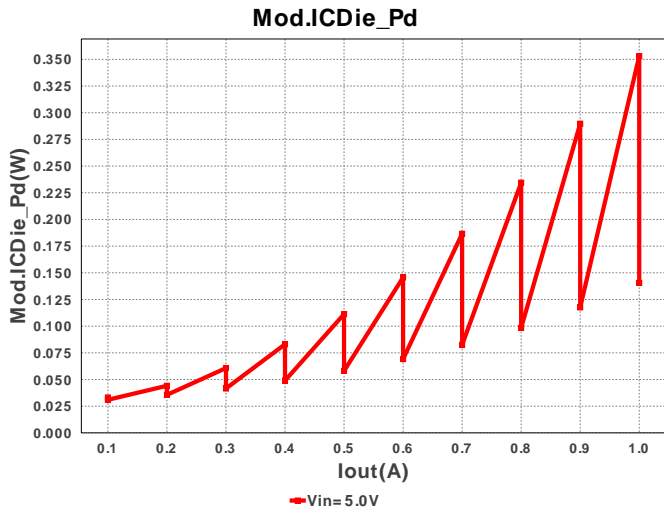
#	Name	Manufacturer	Part Number	Properties	Qty	Price	Footprint
1.	Cin	MuRata	GRM188R60J106ME47D Series= X5R	Cap= 10.0 µF ESR= 9.0 mOhm VDC= 6.3 V IRMS= 2.74 A	1	\$0.03	0603 5mm2
2.	Cout	MuRata	GRM188R60J106ME47D Series= X5R	Cap= 10.0 µF ESR= 9.0 mOhm VDC= 6.3 V IRMS= 2.74 A	1	\$0.03	0603 5mm2
3.	Cvc	MuRata	GRM1555C1E471JA01D Series= C0G/NP0	Cap= 470.0 pF VDC= 25.0 V IRMS= 0.0 A	1	\$0.01	0402 3mm2
4.	Rfbb	Vishay-Dale	CRCW0402105KFKED Series= CRCW..e3	Res= 105.0 kOhm Power= 63.0 mW Tolerance= 1.0%	1	\$0.01	0402 3mm2
5.	Rfbb	Vishay-Dale	CRCW040280K6FKED Series= CRCW..e3	Res= 80.6 kOhm Power= 63.0 mW Tolerance= 1.0%	1	\$0.01	0402 3mm2
6.	U1	Texas Instruments	LMZ10501SILR	Switcher	1	\$1.55	SIL0008A 14mm2

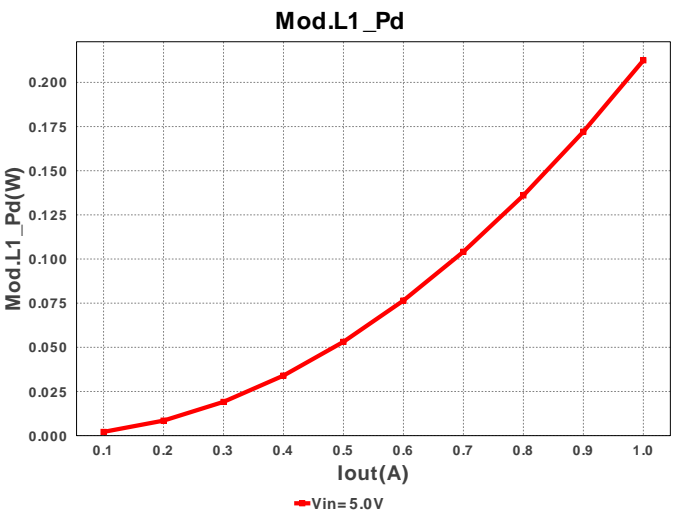
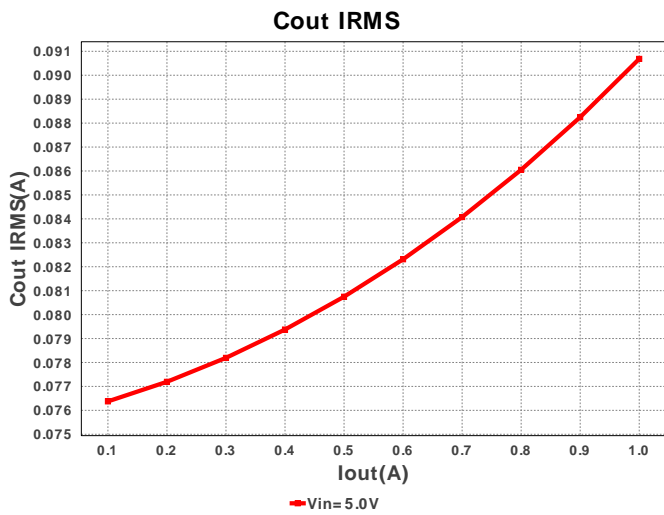
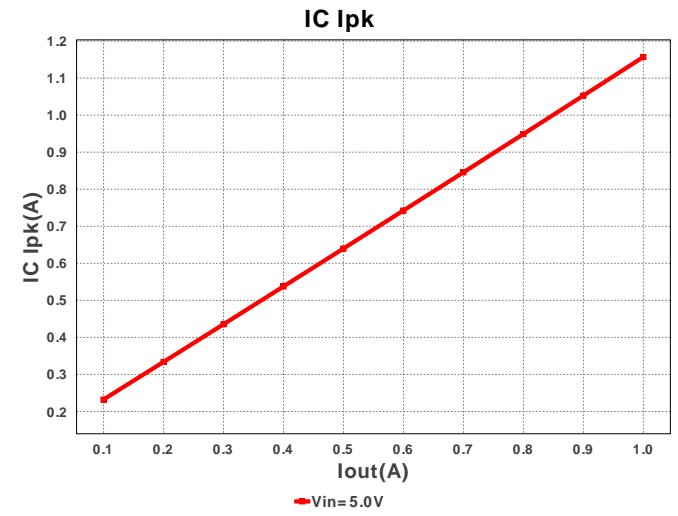
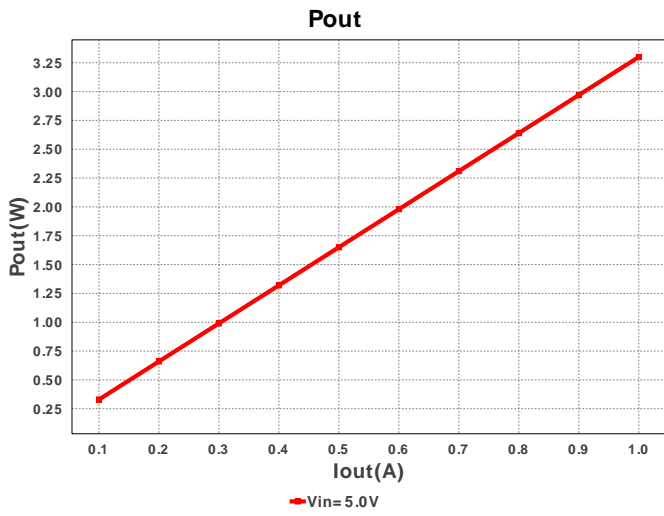
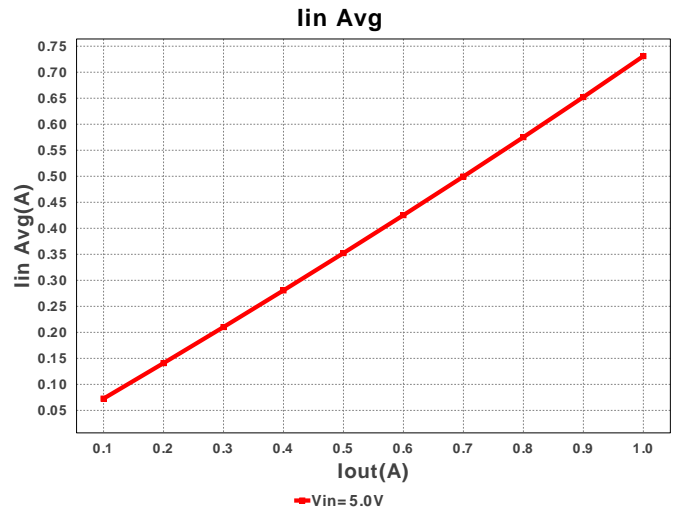
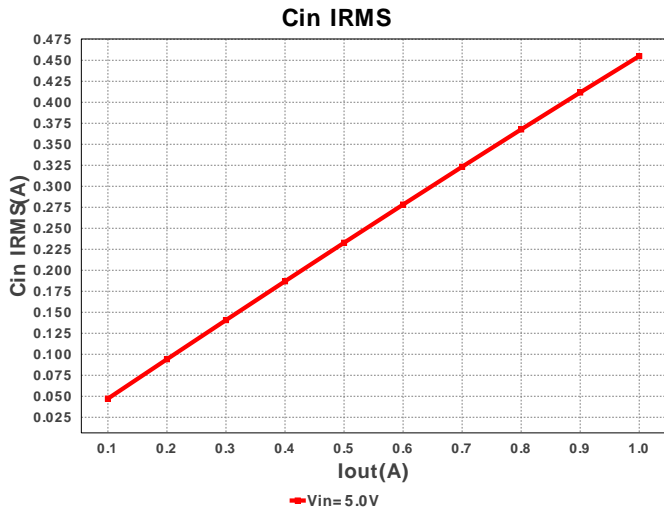

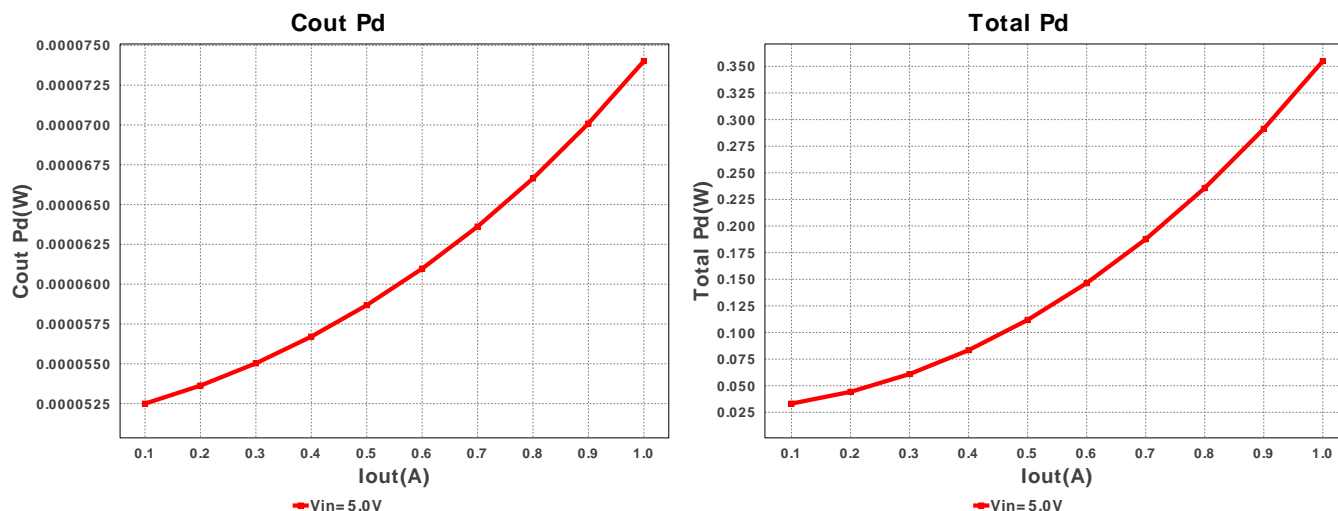



## Operating Values

#	Name	Value	Category	Description
1.	Cin IRMS	454.973 mA	Current	Input capacitor RMS ripple current
2.	Cout IRMS	90.684 mA	Current	Output capacitor RMS ripple current
3.	IC Ipk	1.157 A	Current	Peak switch current in IC
4.	Iin Avg	730.99 mA	Current	Average input current
5.	BOM Count	6	General	Total Design BOM count
6.	FootPrint	33.0 mm <sup>2</sup>	General	Total Foot Print Area of BOM components
7.	Frequency	2.0 MHz	General	Switching frequency
8.	Pout	3.3 W	General	Total output power
9.	Total BOM	\$1.64	General	Total BOM Cost
10.	Vout OP	3.3 V	Op_Point	Operational Output Voltage
11.	Duty Cycle	70.736 %	Op_point	Duty cycle
12.	Efficiency	90.289 %	Op_point	Steady state efficiency
13.	IC Tj	57.181 degC	Op_point	IC junction temperature
14.	ICThetaJA	77.0 degC/W	Op_point	IC junction-to-ambient thermal resistance
15.	IOUT_OP	1.0 A	Op_point	Iout operating point
16.	VIN_OP	5.0 V	Op_point	Vin operating point
17.	Vout p-p	3.442 mV	Op_point	Peak-to-peak output ripple voltage
18.	Cin Pd	1.863 mW	Power	Input capacitor power dissipation
19.	Cout Pd	74.013 μW	Power	Output capacitor power dissipation
20.	Total Pd	354.932 mW	Power	Total Power Dissipation

## Design Inputs

#	Name	Value	Description
1.	Iout	1.0 A	Maximum Output Current
2.	Iout1	1.0 Amps	Output Current #1
3.	VinMax	5.0 V	Maximum input voltage
4.	VinMin	5.0 V	Minimum input voltage
5.	Vout	3.3 V	Output Voltage
6.	Vout1	3.3 Volt	Output Voltage #1
7.	base_pn	LMZ10501	Base Product Number
8.	source	DC	Input Source Type
9.	Ta	30.0 degC	Ambient temperature

## Design Assistance

1. The LMZ10501 SIMPLE SWITCHER nano module is an easy-to-use step-down DC-DC solution capable of driving up to 1.0A load in space-constrained applications. Only an input capacitor, an output capacitor, a small VCON filter capacitor, and two resistors are required for basic operation. The nano module comes in 8-pin LLP footprint package with an integrated inductor.

2. **LMZ10501** Product Folder : <http://www.ti.com/product/lmz10501> : contains the data sheet and other resources.

Texas Instruments' WEBENCH simulation tools attempt to recreate the performance of a substantially equivalent physical implementation of the design. Simulations are created using Texas Instruments' published specifications as well as the published specifications of other device manufacturers. While Texas Instruments does update this information periodically, this information may not be current at the time the simulation is built. Texas Instruments does not warrant the accuracy or completeness of the specifications or any information contained therein. Texas Instruments does not warrant that any designs or recommended parts will meet the specifications you entered, will be suitable for your application or fit for any particular purpose, or will operate as shown in the simulation in a physical implementation. Texas Instruments does not warrant that the designs are production worthy.

**You should completely validate and test your design implementation to confirm the system functionality for your application prior to production.**

Use of Texas Instruments' WEBENCH simulation tools is subject to [Texas Instruments' Site Terms and Conditions of Use](#). Prototype boards based on WEBENCH created designs are provided AS IS without warranty of any kind for evaluation and testing purposes and are subject to the terms of the [Evaluation License Agreement](#).