

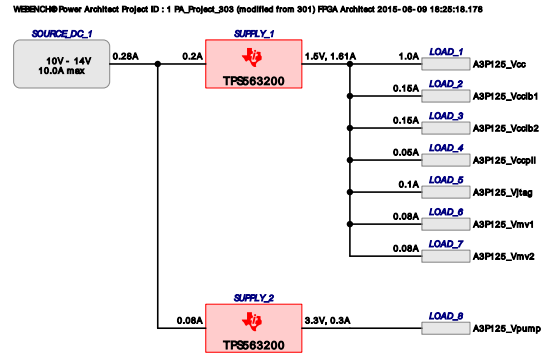

# WEBENCH<sup>®</sup> Power Architect

## Project Report

Project : 4387412/1 : PA\_Project\_303 (modified from 301)  
 Created : 2015-06-09 18:25:18.178  
 Optimize project optFactor=3



### Project Summary

- |                                   |                       |
|-----------------------------------|-----------------------|
| 1. Total System Efficiency        | 87.112 %              |
| 2. Total System BOM Count         | 14.0                  |
| 3. Total System Footprint         | 148.0 mm <sup>2</sup> |
| 4. Total System BOM Cost          | \$2.76                |
| 5. Total System Power Dissipation | 503.8 mW              |

--> Launch WEBENCH Power Architect.

### Power Supplies

#	Name	NSID	Description	Vout	Iout	Efficiency	Foot-print	Cost	Design	Page
1.	SUPPLY_1	TPS563200	Switcher : 17V, 3A,6-pin, Low Iq Synchronous buck converter with Advanced Eco-mode	1.5 V	1.61 A	85.6%	74	\$1.38	6	4
2.	SUPPLY_2	TPS563200	Switcher : 17V, 3A,6-pin, Low Iq Synchronous buck converter with Advanced Eco-mode	3.3 V	0.3 A	91%	74	\$1.38	7	9

### Power Loads

#	Name	VLoad	Iload	Description
1.	A3P125_Vcc	1.5 V	1 A	VoutRipple=5%, SoftStart delay=1.0 mSec
2.	A3P125_Vccib1	1.5 V	0.15 A	VoutRipple=5%, SoftStart delay=1.0 mSec
3.	A3P125_Vccib2	1.5 V	0.15 A	VoutRipple=5%, SoftStart delay=1.0 mSec
4.	A3P125_Vccpll	1.5 V	0.05 A	VoutRipple=5%, SoftStart delay=1.0 mSec
5.	A3P125_Vjtag	1.5 V	0.1 A	VoutRipple=5%, SoftStart delay=1.0 mSec
6.	A3P125_Vmv1	1.5 V	0.08 A	VoutRipple=5%, SoftStart delay=1.0 mSec
7.	A3P125_Vmv2	1.5 V	0.08 A	VoutRipple=5%, SoftStart delay=1.0 mSec
8.	A3P125_Vpump	3.3 V	0.3 A	VoutRipple=9%, Group=Pump, SoftStart delay=1.0 mSec

### FPGAs, Processors

#	Manufacturer	Part Number	Name	Series	Description
1.	Actel	A3P125	FPGA_1	ProASIC3	FPGA Actel ProASIC3 A3P125

[http://www.actel.com/documents/PA3\\_DS.pdf](http://www.actel.com/documents/PA3_DS.pdf)

## Project Diagram

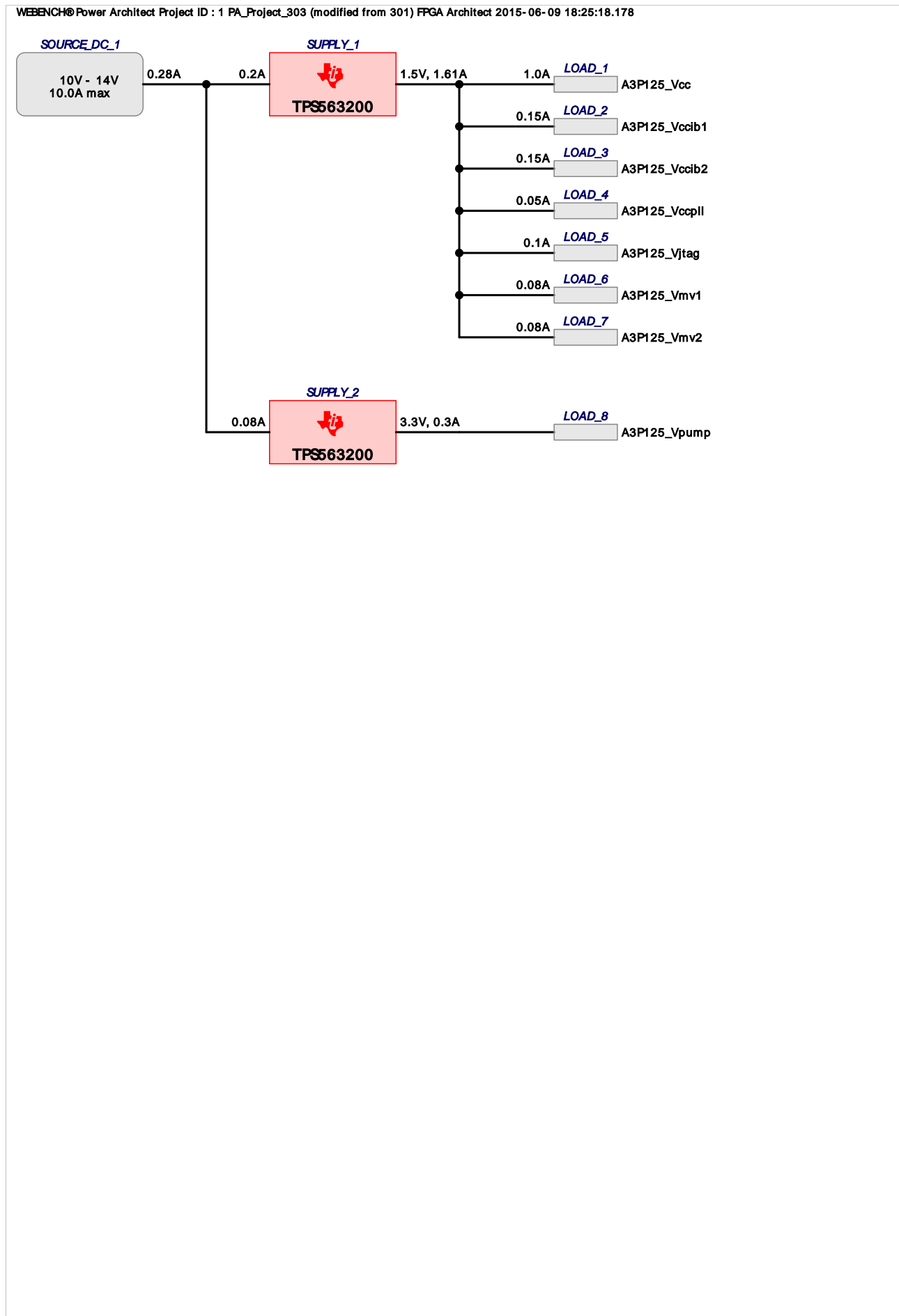

## Electrical Procurement BOM

Manufacturer	Part Number	Description	Quantity	Budgetary Price	Footprint (mm <sup>2</sup> )
AVX	08053C104KAT2A	0805	2	\$0.01	14
Vishay-Dale	CRCW040210K0FKED	0402	2	\$0.01	6
Vishay-Dale	CRCW040233K2FKED	0402	1	\$0.01	3
Vishay-Dale	CRCW04029K76FKED	0402	1	\$0.01	3
MuRata	GRM31CR60J476ME19L	1206	2	\$0.12	22
MuRata	GRM32ER61E226KE15L	1210	2	\$0.16	29
Texas Instruments	TPS563200DDCR	DDC0006A	2	\$0.52	21
Coilcraft	XFL4020-152MEB	XFL4020	1	\$0.55	25
Coilcraft	XFL4020-222MEB	XFL4020	1	\$0.55	25
<b>Total</b>			<b>14</b>	<b>\$2.76</b>	<b>148</b>



VinMin = 10.0V  
 VinMax = 14.0V  
 Vout = 1.5V  
 Iout = 1.61A

Device = TPS563200DDCR  
 Topology = Buck  
 Created = 6/9/15 6:25:17 PM  
 BOM Cost = \$1.38  
 Footprint = 74.0 mm<sup>2</sup>  
 BOM Count = 7  
 Total Pd = 0.41W

## WEBENCH® Design Report

Design : 4387412/6 TPS563200DDCR  
 TPS563200DDCR 10.0V-14.0V to 1.50V @ 1.61A

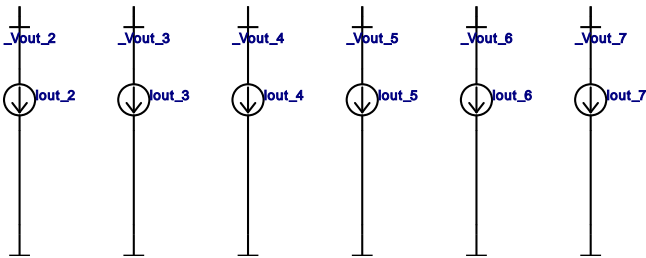
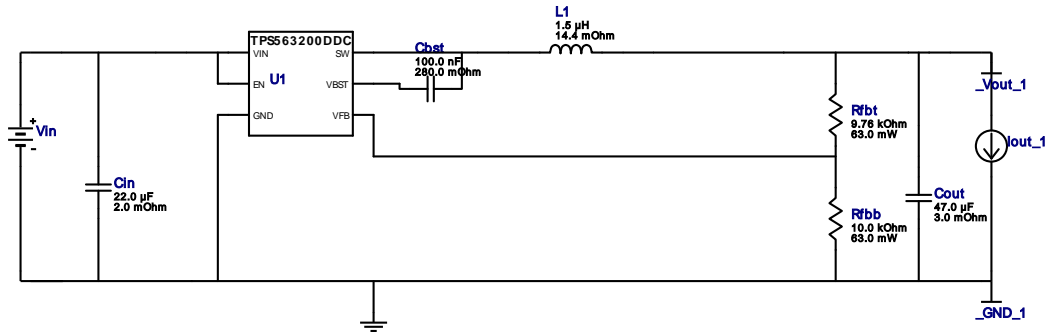

### Electrical BOM

#	Name	Manufacturer	Part Number	Properties	Qty	Price	Footprint
1.	Cbst	AVX	08053C104KAT2A Series= X7R	Cap= 100.0 nF ESR= 280.0 mOhm VDC= 25.0 V IRMS= 0.0 A	1	\$0.01	0805 7 mm <sup>2</sup>
2.	Cin	MuRata	GRM32ER61E226KE15L Series= X5R	Cap= 22.0 uF ESR= 2.0 mOhm VDC= 25.0 V IRMS= 3.67 A	1	\$0.16	1210 15 mm <sup>2</sup>
3.	Cout	MuRata	GRM31CR60J476ME19L Series= X5R	Cap= 47.0 uF ESR= 3.0 mOhm VDC= 6.3 V IRMS= 0.0 A	1	\$0.12	1206 11 mm <sup>2</sup>
4.	L1	Coilcraft	XFL4020-152MEB	L= 1.5 uH DCR= 14.4 mOhm	1	\$0.55	XFL4020 25 mm <sup>2</sup>
5.	Rfbb	Vishay-Dale	CRCW040210K0FKED Series= CRCW..e3	Res= 10.0 kOhm Power= 63.0 mW Tolerance= 1.0%	1	\$0.01	0402 3 mm <sup>2</sup>
6.	Rfbt	Vishay-Dale	CRCW04029K76FKED Series= CRCW..e3	Res= 9.76 kOhm Power= 63.0 mW Tolerance= 1.0%	1	\$0.01	0402 3 mm <sup>2</sup>
7.	U1	Texas Instruments	TPS563200DDCR	Switcher	1	\$0.52	DDC0006A 10 mm <sup>2</sup>

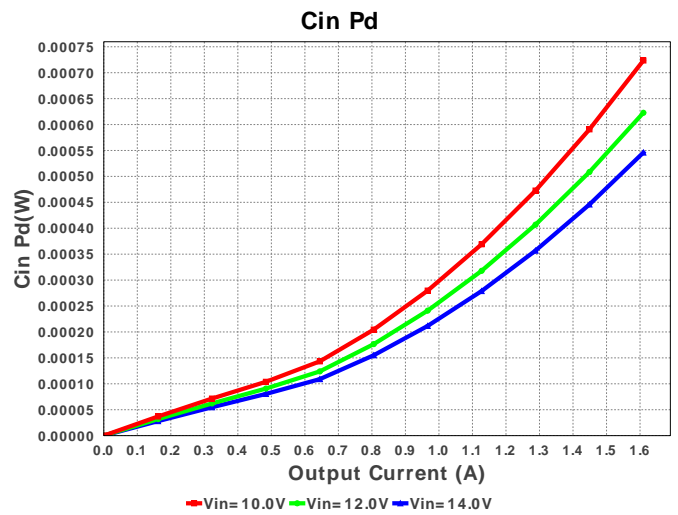
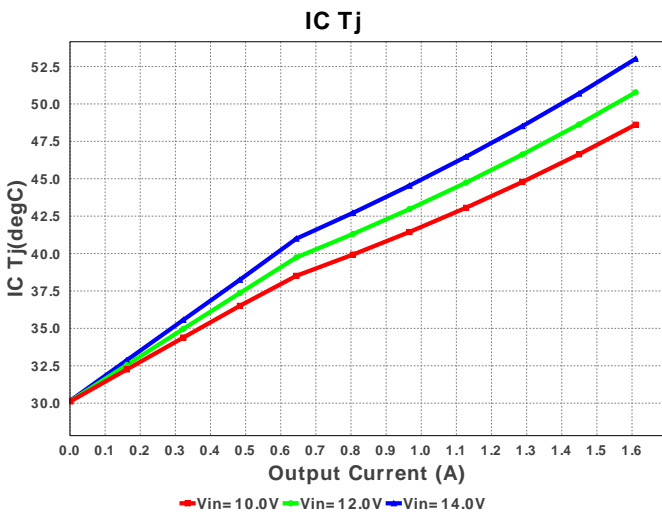
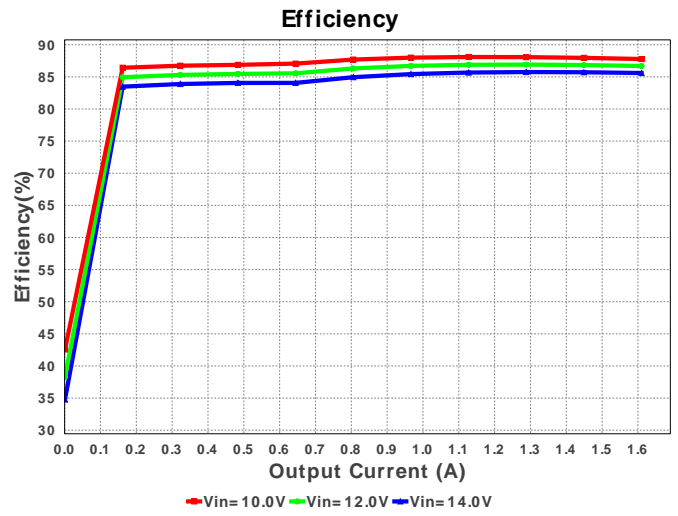
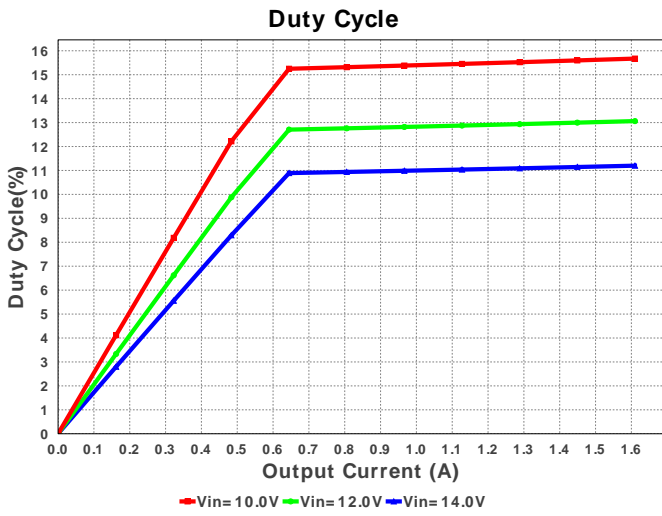
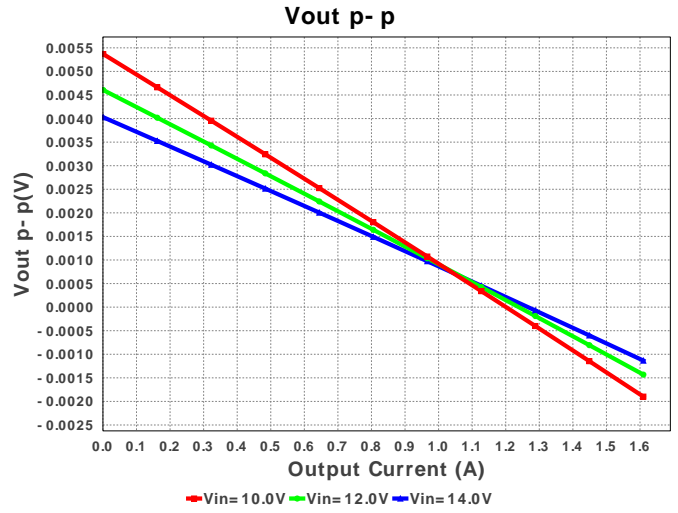
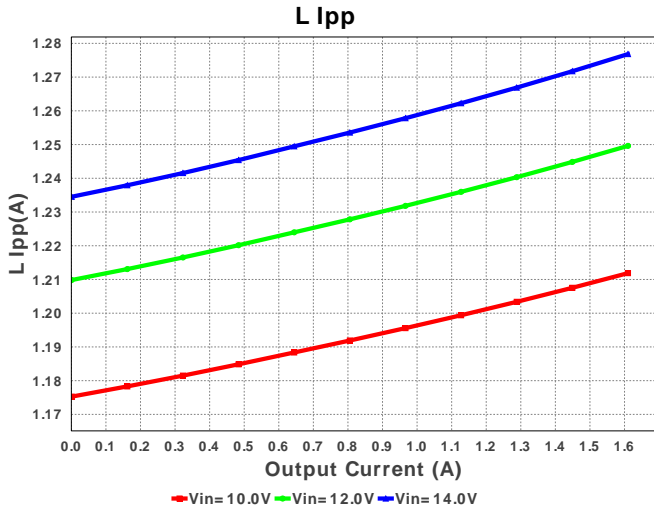

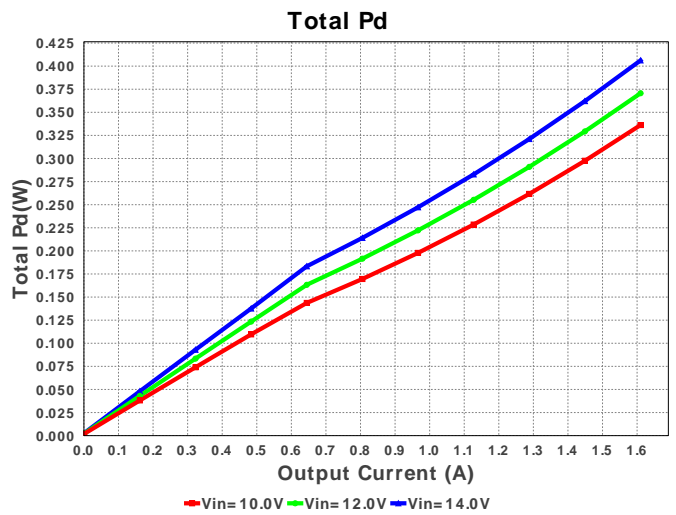
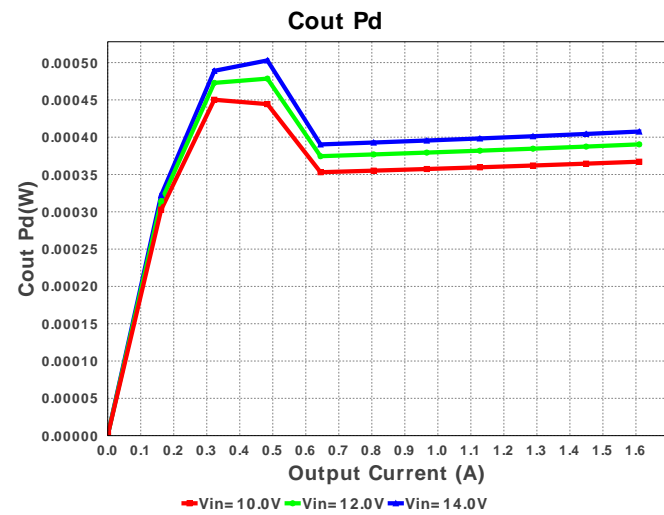
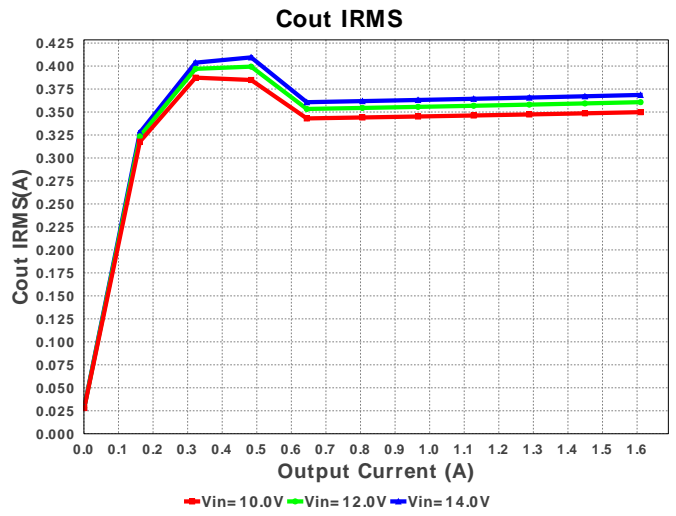
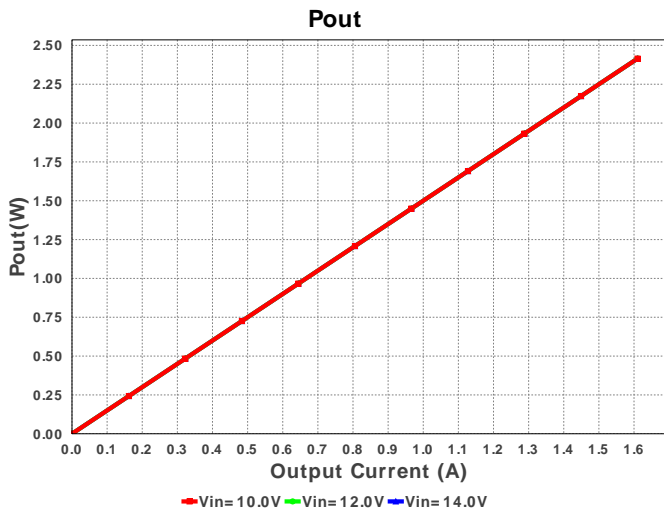
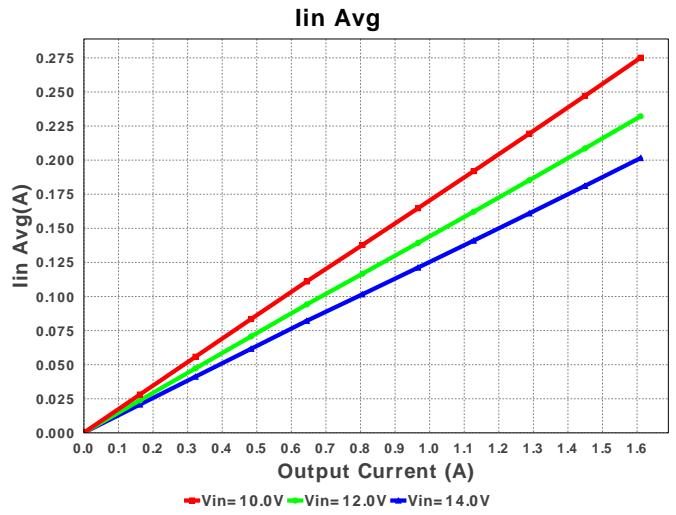
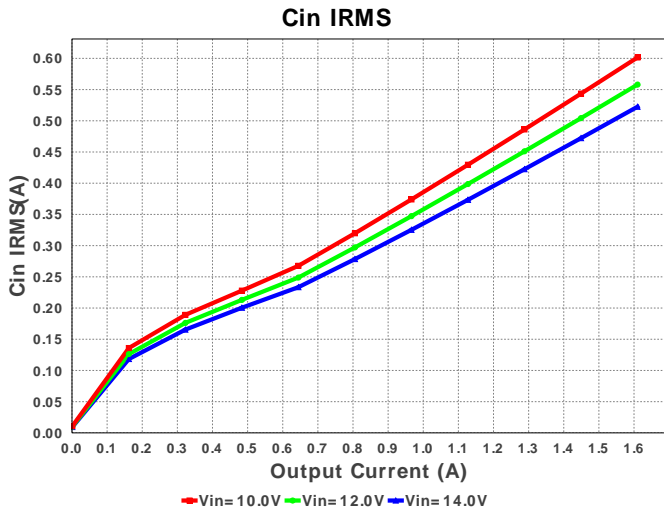

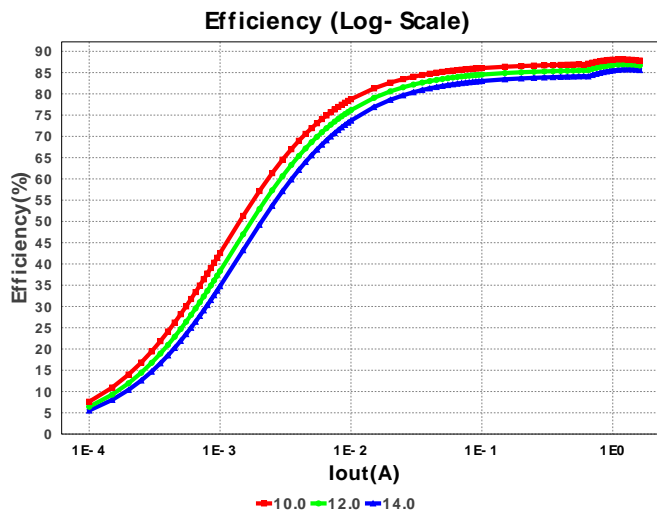
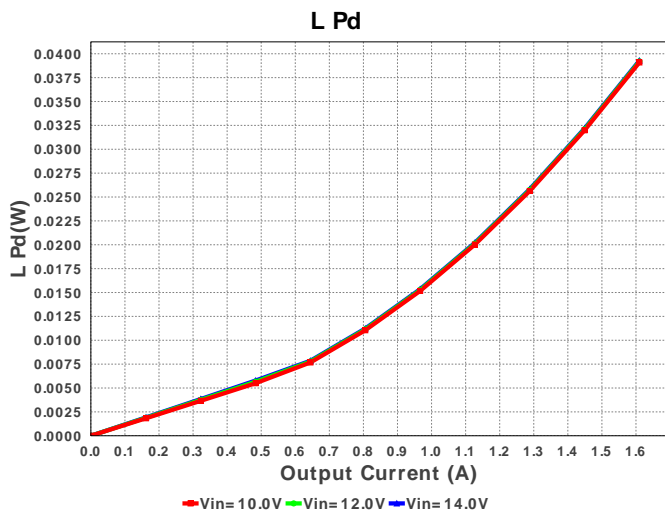
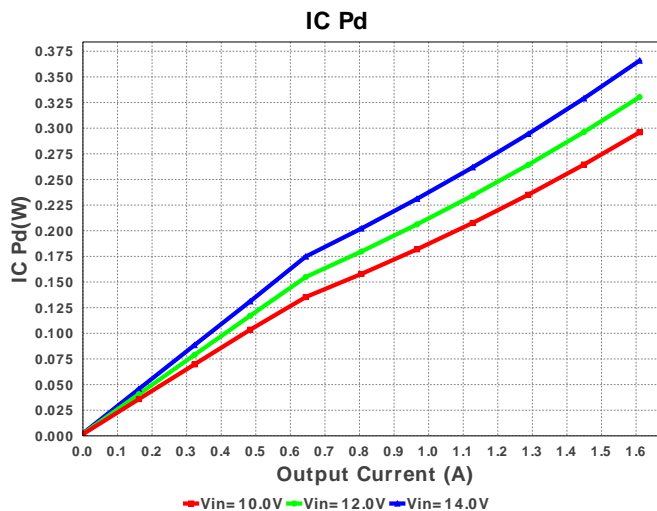
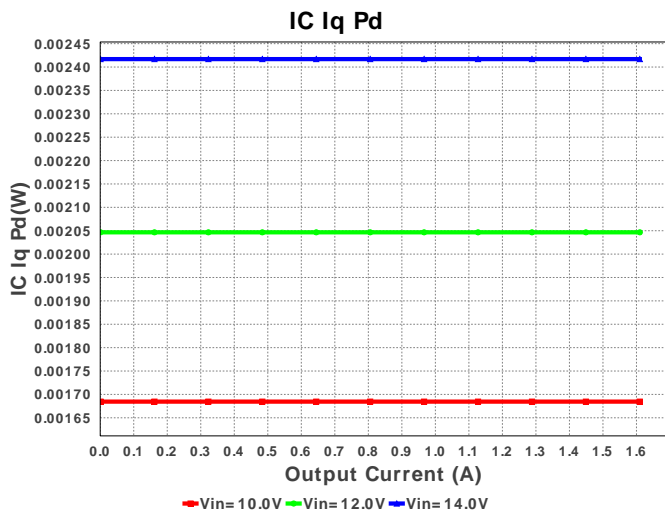

Operating Values

#	Name	Value	Category	Description
1.	Cin IRMS	522.507 mA	Current	Input capacitor RMS ripple current
2.	Cout IRMS	368.585 mA	Current	Output capacitor RMS ripple current
3.	Iin Avg	201.51 mA	Current	Average input current
4.	L Ipp	1.277 A	Current	Peak-to-peak inductor ripple current
5.	BOM Count	7	General	Total Design BOM count
6.	FootPrint	74.0 mm <sup>2</sup>	General	Total Foot Print Area of BOM components
7.	Frequency	725.245 kHz	General	Switching frequency
8.	Pout	2.415 W	General	Total output power
9.	Total BOM	\$1.38	General	Total BOM Cost
10.	Vout OP	1.5 V	Op_Point	Operational Output Voltage
11.	Duty Cycle	11.2 %	Op_point	Duty cycle
12.	Efficiency	85.602 %	Op_point	Steady state efficiency
13.	IC Tj	53.012 degC	Op_point	IC junction temperature
14.	ICThetaJA	62.9 degC/W	Op_point	IC junction-to-ambient thermal resistance
15.	IOUT_OP	1.61 A	Op_point	Iout operating point
16.	VIN_OP	14.0 V	Op_point	Vin operating point
17.	Vout p-p	6.435 mV	Op_point	Peak-to-peak output ripple voltage
18.	Cin Pd	546.027 μW	Power	Input capacitor power dissipation
19.	Cout Pd	407.566 μW	Power	Output capacitor power dissipation
20.	IC Iq Pd	2.417 mW	Power	IC Iq Pd
21.	IC Pd	365.847 mW	Power	IC power dissipation
22.	L Pd	39.283 mW	Power	Inductor power dissipation
23.	Total Pd	406.188 mW	Power	Total Power Dissipation

Design Inputs

#	Name	Value	Description
1.	Iout	1.61	Maximum Output Current
2.	Iout1	1.61	Output Current #1
3.	SoftStart	1.0 ms	Soft Start Time (ms)
4.	VinMax	14.0	Maximum input voltage

---

#	Name	Value	Description
5.	VinMin	10.0	Minimum input voltage
6.	Vout	1.5	Output Voltage
7.	Vout1	1.5	Output Voltage #1
8.	base_pn	TPS563200	Texas Instruments Base Part Number
9.	source	DC	Input Source Type
10.	ta	30.0	Ambient temperature

## Design Assistance

1. TPS563200 Product Folder : <http://www.ti.com/product/TPS563200> : contains the data sheet and other resources.





VinMin = 10.0V  
 VinMax = 14.0V  
 Vout = 3.3V  
 Iout = 0.3A

Device = TPS563200DDCR  
 Topology = Buck  
 Created = 6/9/15 6:25:17 PM  
 BOM Cost = \$1.38  
 Footprint = 74.0 mm<sup>2</sup>  
 BOM Count = 7  
 Total Pd = 0.1W

## WEBENCH® Design Report

Design : 4387412/7 TPS563200DDCR  
 TPS563200DDCR 10.0V-14.0V to 3.30V @ 0.3A

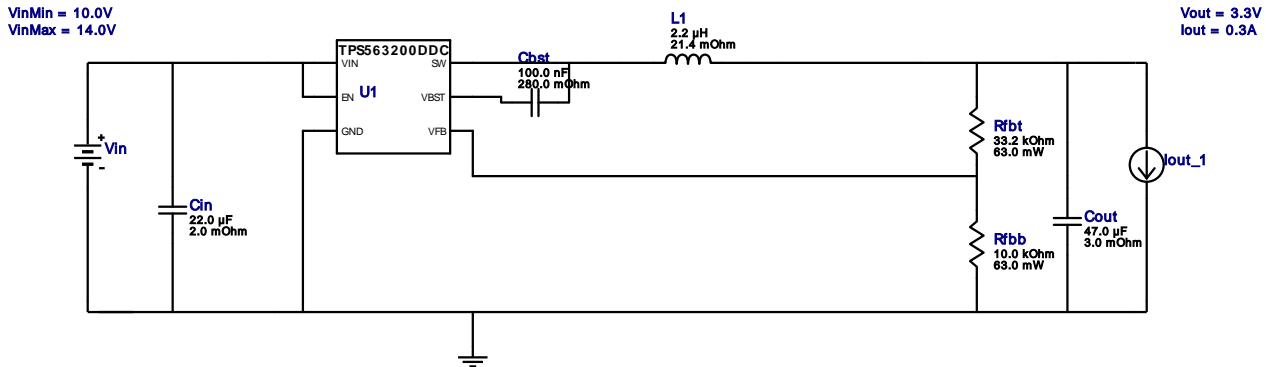

## Electrical BOM

#	Name	Manufacturer	Part Number	Properties	Qty	Price	Footprint
1.	Cbst	AVX	08053C104KAT2A Series= X7R	Cap= 100.0 nF ESR= 280.0 mOhm VDC= 25.0 V IRMS= 0.0 A	1	\$0.01	0805 7 mm <sup>2</sup>
2.	Cin	MuRata	GRM32ER61E226KE15L Series= X5R	Cap= 22.0 uF ESR= 2.0 mOhm VDC= 25.0 V IRMS= 3.67 A	1	\$0.16	1210 15 mm <sup>2</sup>
3.	Cout	MuRata	GRM31CR60J476ME19L Series= X5R	Cap= 47.0 uF ESR= 3.0 mOhm VDC= 6.3 V IRMS= 0.0 A	1	\$0.12	1206 11 mm <sup>2</sup>
4.	L1	Coilcraft	XFL4020-222MEB	L= 2.2 uH DCR= 21.4 mOhm	1	\$0.55	XFL4020 25 mm <sup>2</sup>
5.	Rfbb	Vishay-Dale	CRCW040210K0FKED Series= CRCW..e3	Res= 10.0 kOhm Power= 63.0 mW Tolerance= 1.0%	1	\$0.01	0402 3 mm <sup>2</sup>
6.	Rfbt	Vishay-Dale	CRCW040233K2FKED Series= CRCW..e3	Res= 33.2 kOhm Power= 63.0 mW Tolerance= 1.0%	1	\$0.01	0402 3 mm <sup>2</sup>
7.	U1	Texas Instruments	TPS563200DDCR	Switcher	1	\$0.52	DDC0006A 10 mm <sup>2</sup>

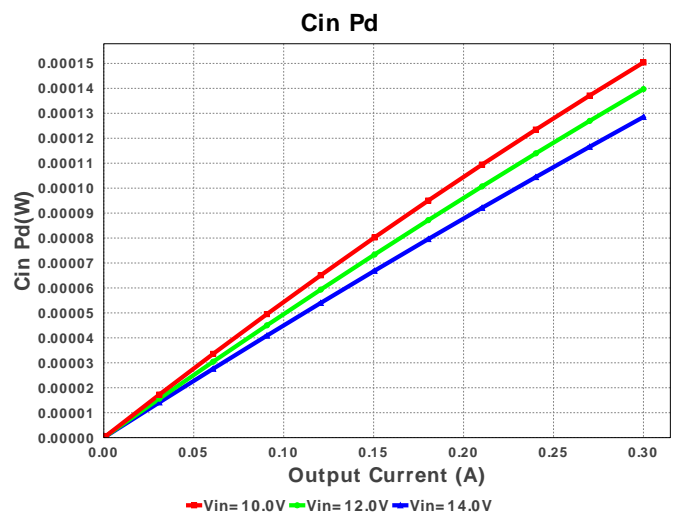
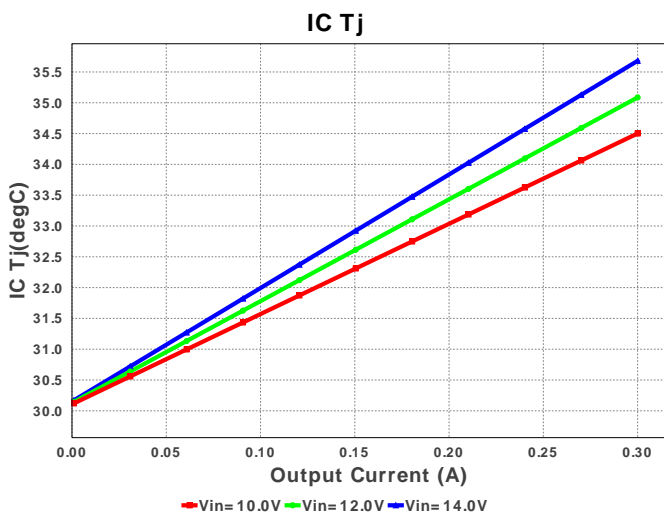
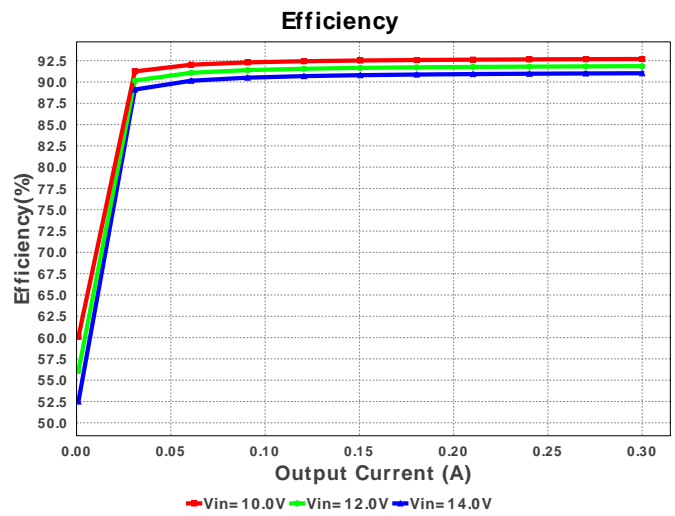
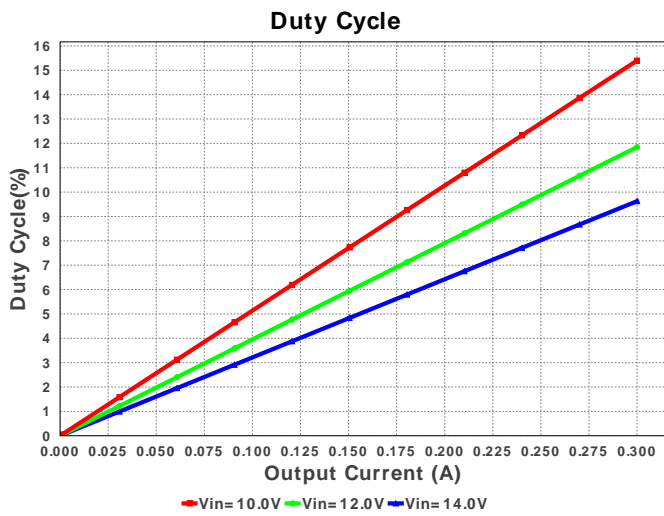
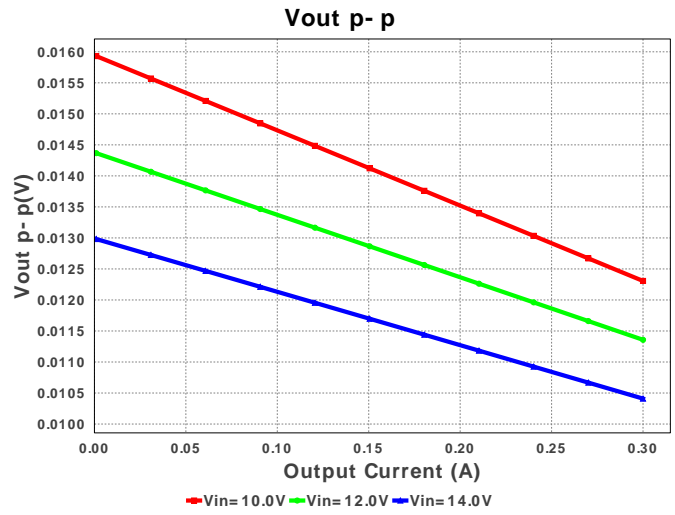
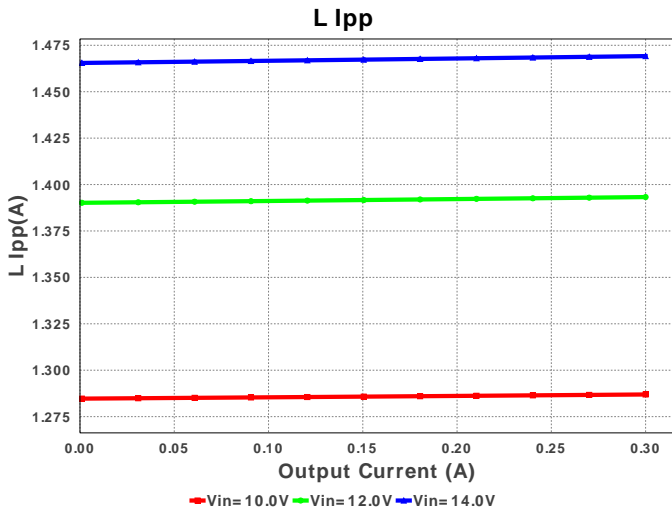

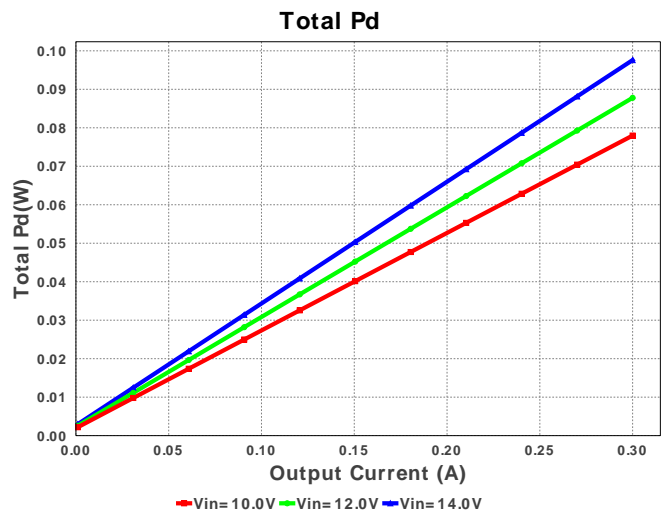
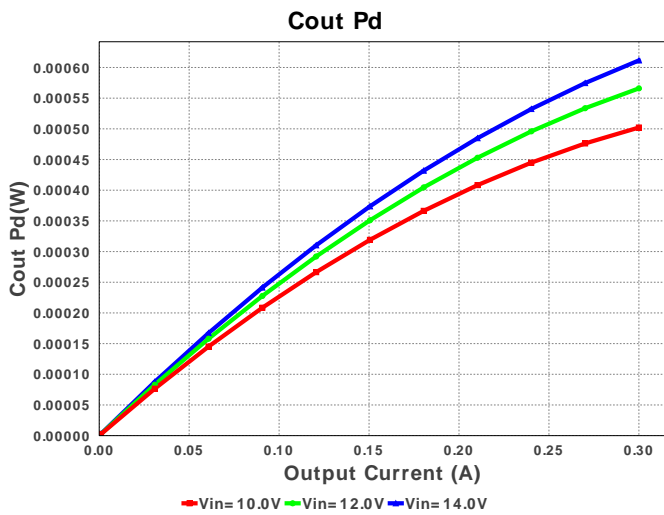
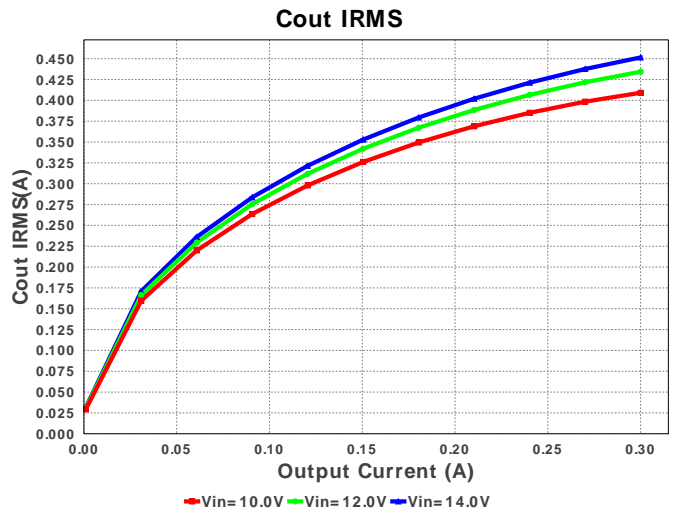
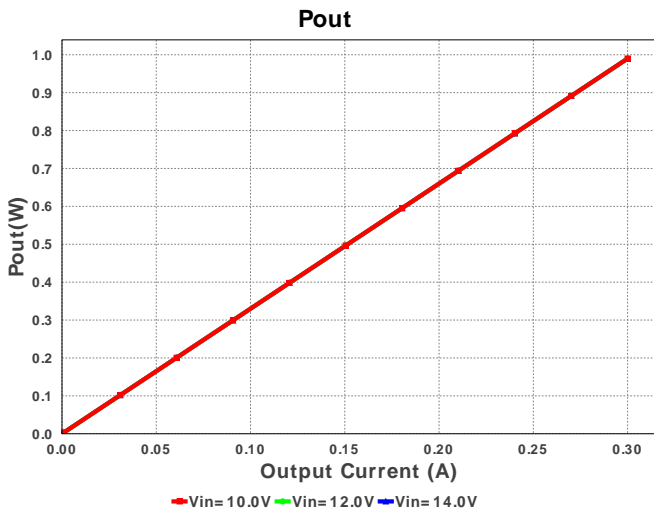
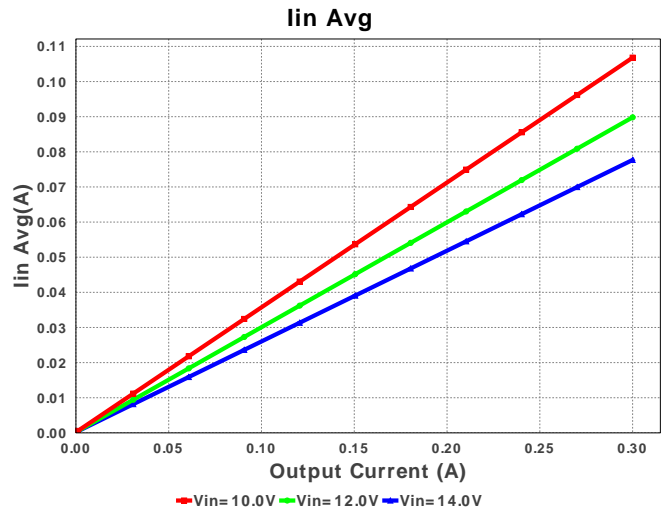
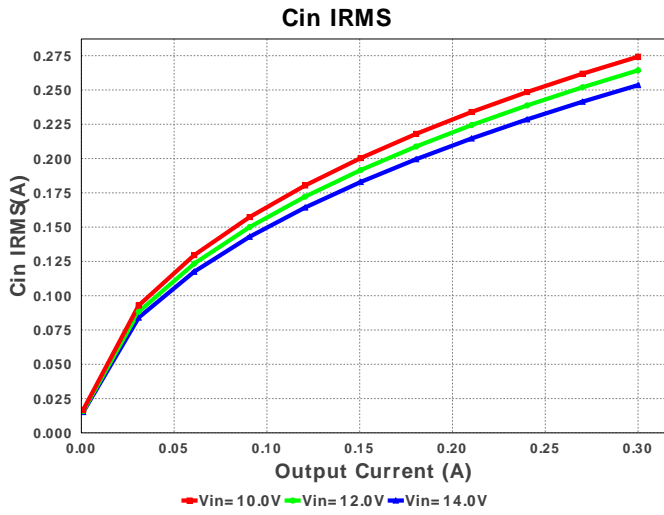

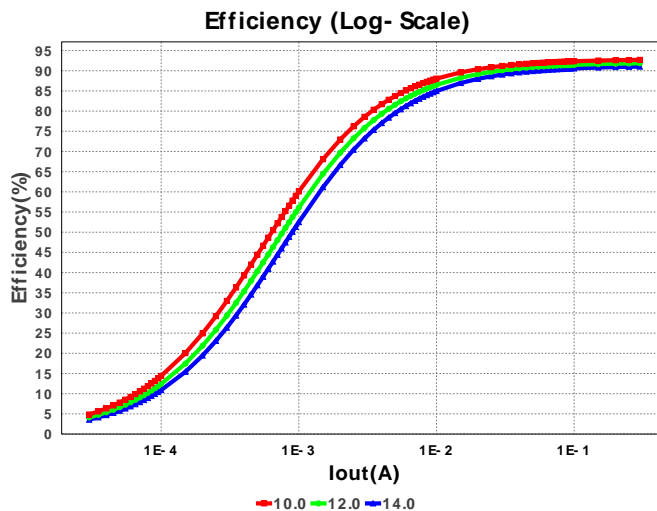
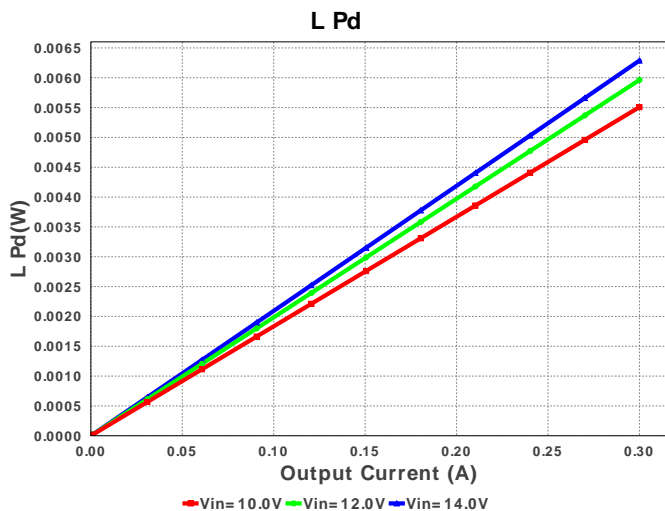
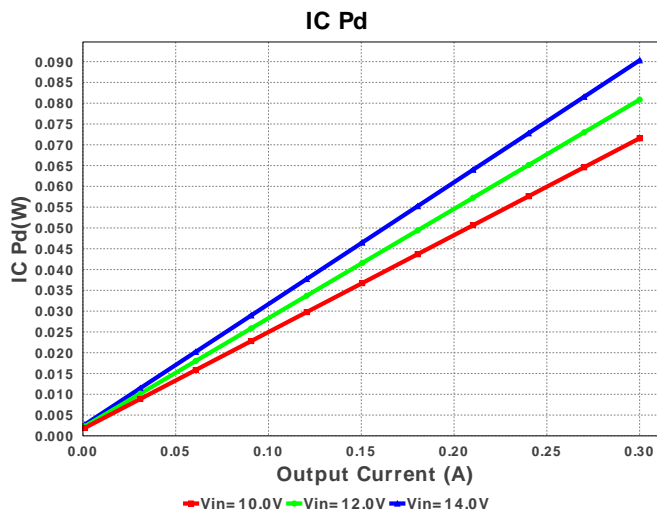
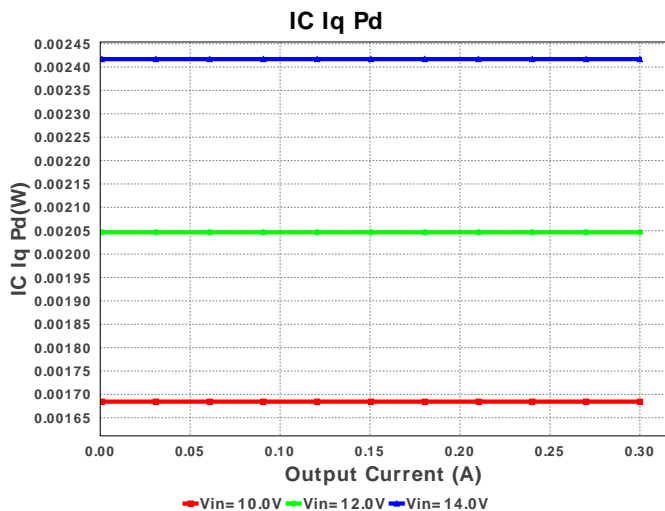

Operating Values

#	Name	Value	Category	Description
1.	Cin IRMS	253.512 mA	Current	Input capacitor RMS ripple current
2.	Cout IRMS	451.482 mA	Current	Output capacitor RMS ripple current
3.	Iin Avg	77.685 mA	Current	Average input current
4.	L Ipp	1.469 A	Current	Peak-to-peak inductor ripple current
5.	BOM Count	7	General	Total Design BOM count
6.	FootPrint	74.0 mm <sup>2</sup>	General	Total Foot Print Area of BOM components
7.	Frequency	318.109 kHz	General	Switching frequency
8.	Pout	990.0 mW	General	Total output power
9.	Total BOM	\$1.38	General	Total BOM Cost
10.	Vout OP	3.3 V	Op_Point	Operational Output Voltage
11.	Duty Cycle	9.628 %	Op_point	Duty cycle
12.	Efficiency	91.027 %	Op_point	Steady state efficiency
13.	IC Tj	35.68 degC	Op_point	IC junction temperature
14.	ICThetaJA	62.9 degC/W	Op_point	IC junction-to-ambient thermal resistance
15.	IOUT_OP	300.0 mA	Op_point	Iout operating point
16.	VIN_OP	14.0 V	Op_point	Vin operating point
17.	Vout p-p	13.081 mV	Op_point	Peak-to-peak output ripple voltage
18.	Cin Pd	128.536 μW	Power	Input capacitor power dissipation
19.	Cout Pd	611.507 μW	Power	Output capacitor power dissipation
20.	IC Iq Pd	2.417 mW	Power	IC Iq Pd
21.	IC Pd	90.304 mW	Power	IC power dissipation
22.	L Pd	6.288 mW	Power	Inductor power dissipation
23.	Total Pd	97.589 mW	Power	Total Power Dissipation

Design Inputs

#	Name	Value	Description
1.	Iout	300.0 m	Maximum Output Current
2.	Iout1	300.0 m	Output Current #1
3.	SoftStart	1.0 ms	Soft Start Time (ms)
4.	VinMax	14.0	Maximum input voltage

#	Name	Value	Description
5.	VinMin	10.0	Minimum input voltage
6.	Vout	3.3	Output Voltage
7.	Vout1	3.3	Output Voltage #1
8.	base_pn	TPS563200	Texas Instruments Base Part Number
9.	source	DC	Input Source Type
10.	ta	30.0	Ambient temperature

## Design Assistance

1. TPS563200 Product Folder : <http://www.ti.com/product/TPS563200> : contains the data sheet and other resources.

Texas Instruments' WEBENCH simulation tools attempt to recreate the performance of a substantially equivalent physical implementation of the design. Simulations are created using Texas Instruments' published specifications as well as the published specifications of other device manufacturers. While Texas Instruments does update this information periodically, this information may not be current at the time the simulation is built. Texas Instruments does not warrant the accuracy or completeness of the specifications or any information contained therein. Texas Instruments does not warrant that any designs or recommended parts will meet the specifications you entered, will be suitable for your application or fit for any particular purpose, or will operate as shown in the simulation in a physical implementation. Texas Instruments does not warrant that the designs are production worthy.

**You should completely validate and test your design implementation to confirm the system functionality for your application prior to production.**

Use of Texas Instruments' WEBENCH simulation tools is subject to [Texas Instruments' Site Terms and Conditions of Use](#). Prototype boards based on WEBENCH created designs are provided AS IS without warranty of any kind for evaluation and testing purposes and are subject to the terms of the [Evaluation License Agreement](#).