

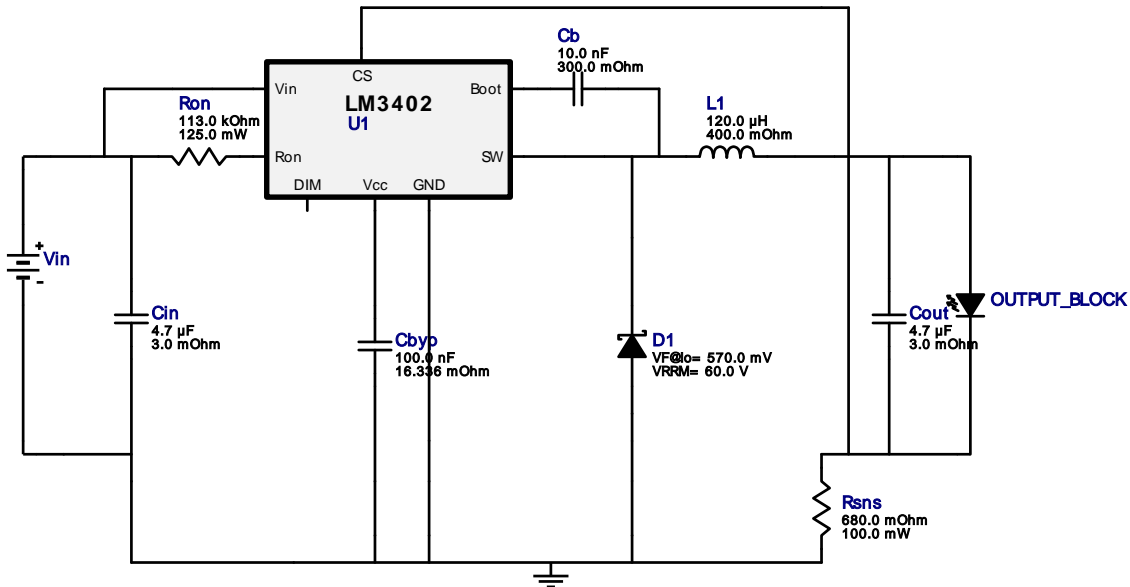







WEBENCH® Design Report

 Design : 4391610/2 LM3402MR/NOPB
 LM3402MR/NOPB 24.0V-32.0V to 3.20V @ 0.35A

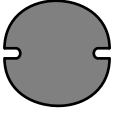
 VinMin = 24.0V
 VinMax = 32.0V

 Vout = 3.0V
 Iout = 0.35A

Electrical BOM

#	Name	Manufacturer	Part Number	Properties	Qty	Price	Footprint
1.	Cb	MuRata	GRM188R71E103KA01D Series= X7R	Cap= 10.0 nF ESR= 300.0 mOhm VDC= 25.0 V IRMS= 0.0 A	1	\$0.01	 0603 5 mm ²
2.	Cbyp	TDK	C1608X7R1E104K Series= X7R	Cap= 100.0 nF ESR= 16.336 mOhm VDC= 25.0 V IRMS= 0.0 A	1	\$0.01	 0603 5 mm ²
3.	Cin	MuRata	GRM31CR71H475KA12L Series= X7R	Cap= 4.7 uF ESR= 3.0 mOhm VDC= 50.0 V IRMS= 4.98 A	1	\$0.07	 1206 11 mm ²
4.	Cout	MuRata	GRM31CR71H475KA12L Series= X7R	Cap= 4.7 uF ESR= 3.0 mOhm VDC= 50.0 V IRMS= 4.98 A	1	\$0.07	 1206 11 mm ²
5.	D1	NXP Semiconductor	PMEG6010CEH,115	VF@Io= 570.0 mV VRRM= 60.0 V	1	\$0.11	 SOD-123F 12 mm ²
6.	D_LED	Cree	XPGWHT-L1-0000-00G51	LED	1	\$1.72	 xlampxpg 20 mm ²
7.	L1	Bourns	SDR1006-121KL	L= 120.0 uH DCR= 400.0 mOhm	1	\$0.27	 SDR1006 139 mm ²

#	Name	Manufacturer	Part Number	Properties	Qty	Price	Footprint
8.	Ron	Panasonic	ERJ-6ENF1133V Series= 225	Res= 113.0 kOhm Power= 125.0 mW Tolerance= 1.0%	1	\$0.01	 0805 7 mm ²
9.	Rsns	Panasonic	ERJ-3RQFR68V Series= 227	Res= 680.0 mOhm Power= 100.0 mW Tolerance= 1.0%	1	\$0.02	 0603 5 mm ²
10.	U1	Texas Instruments	LM3402MR/NOPB	Switcher	1	\$0.96	 MRA08B 56 mm ²

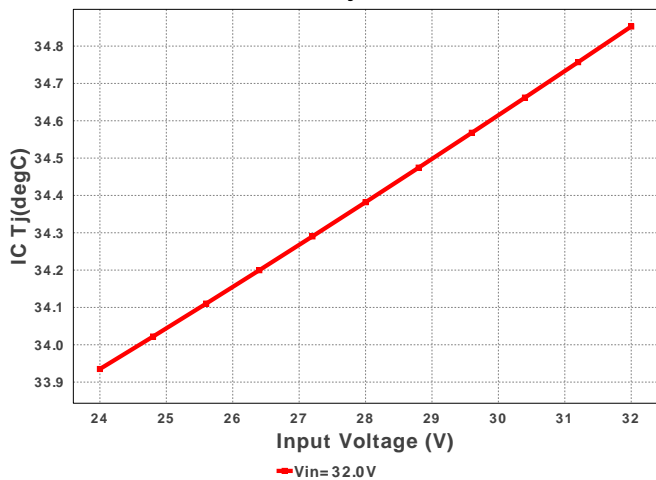
IC Tj



Duty Cycle

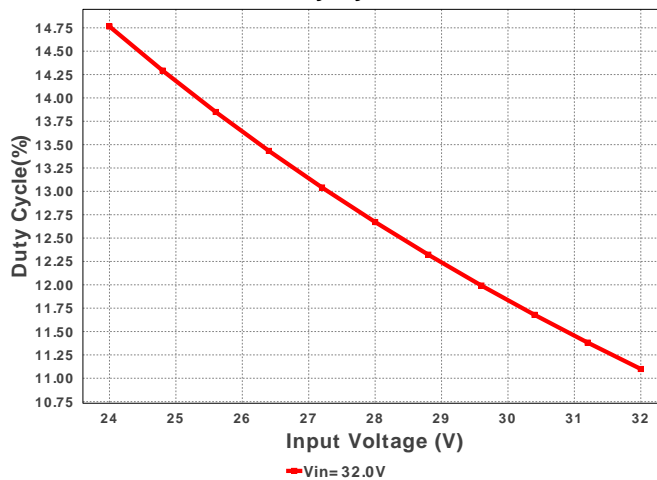

Cin IRMS

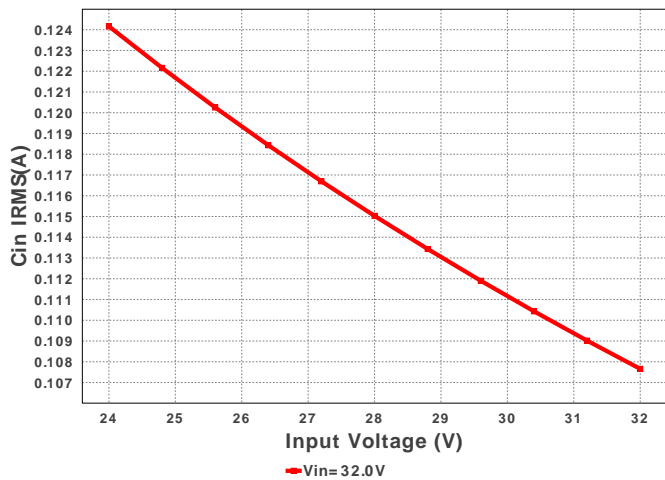

IC Ipk

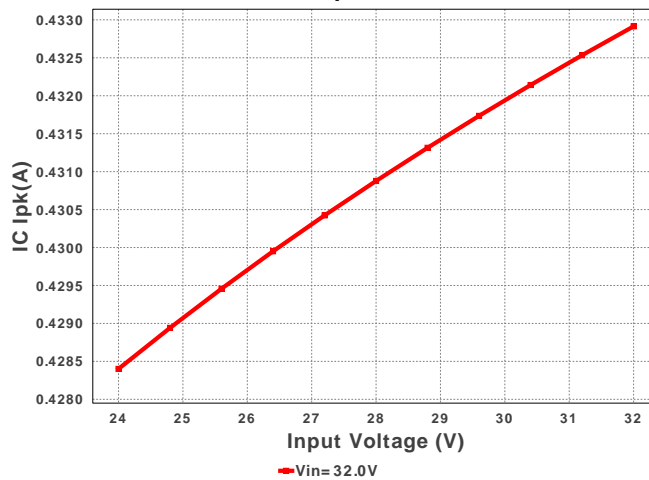

L Pd

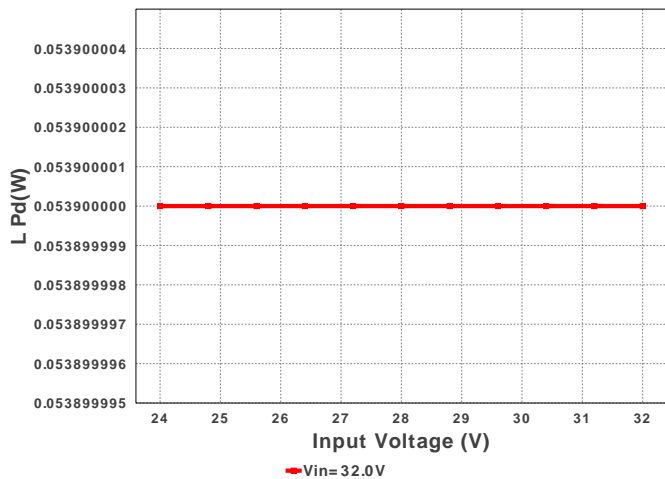

Rsense Pd

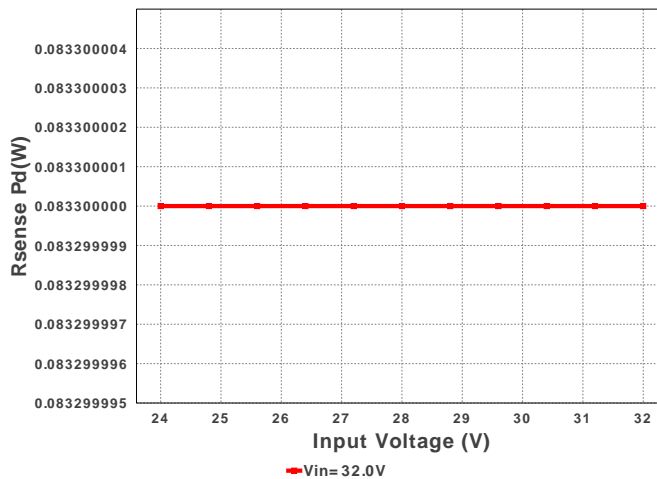

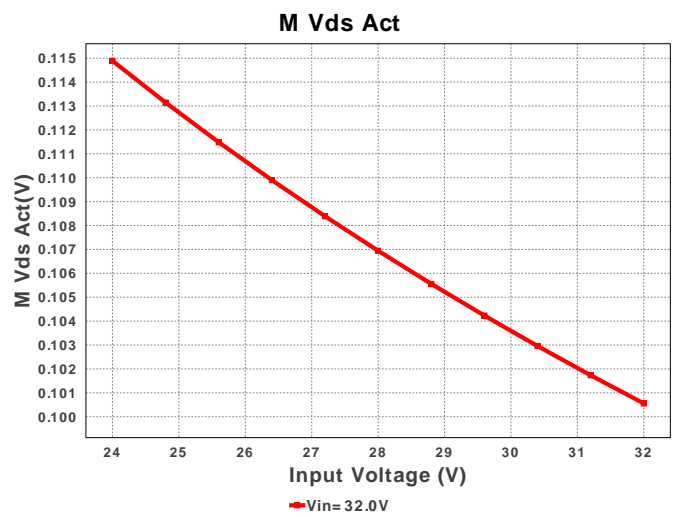
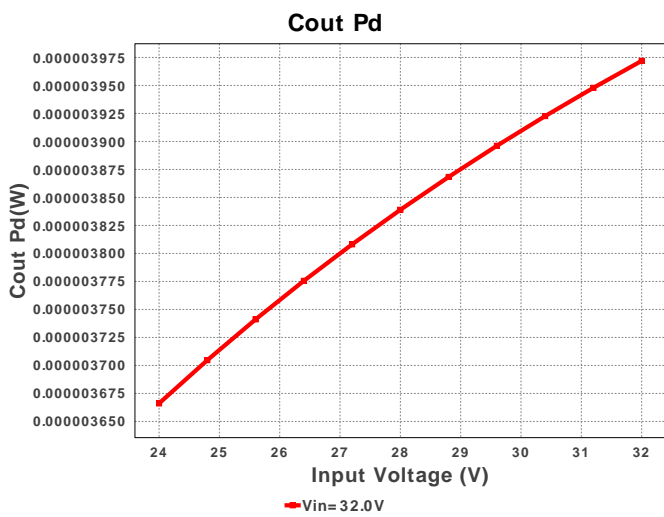
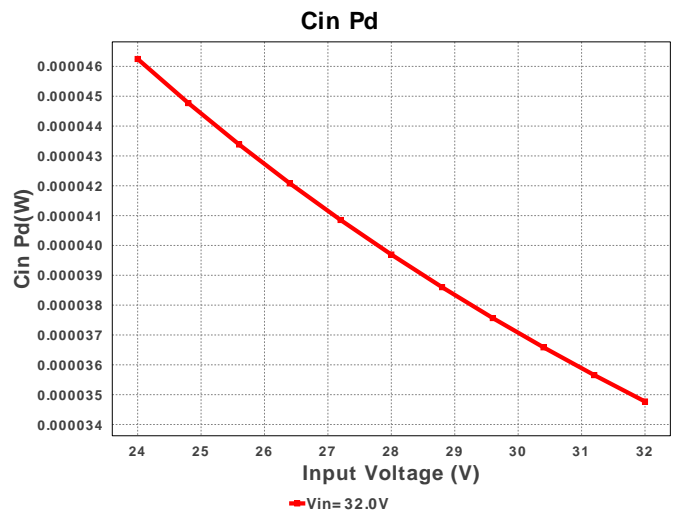
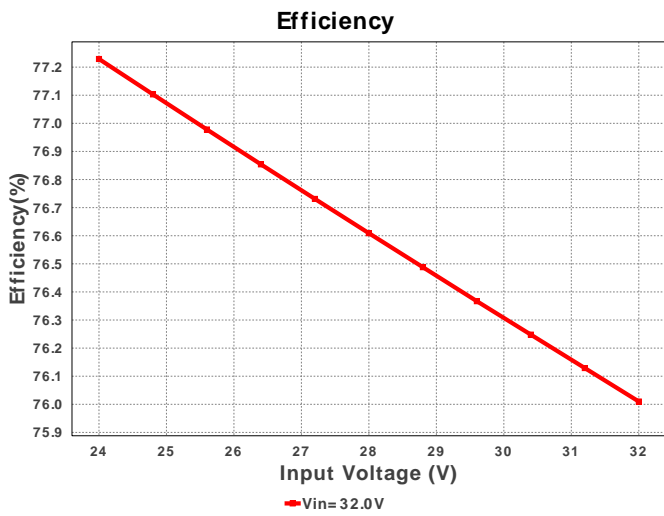
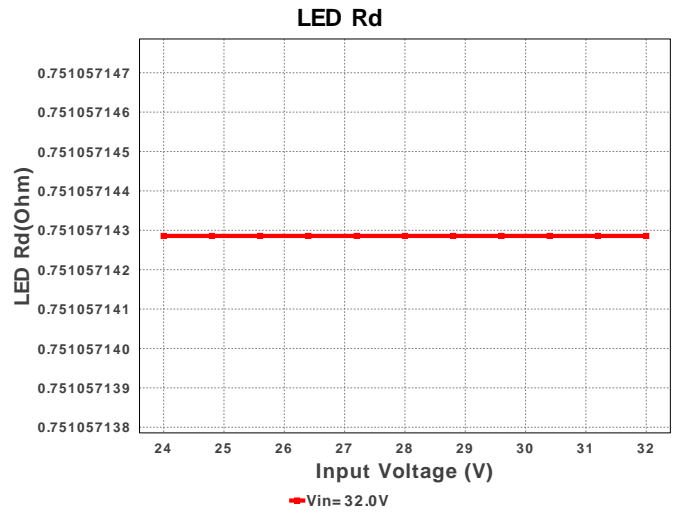
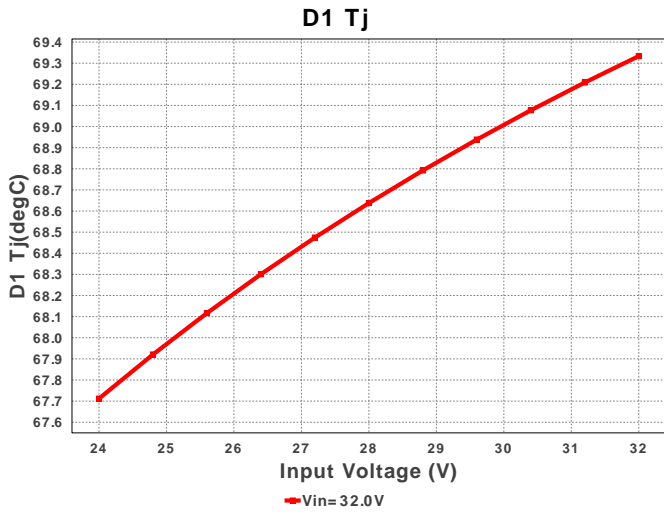

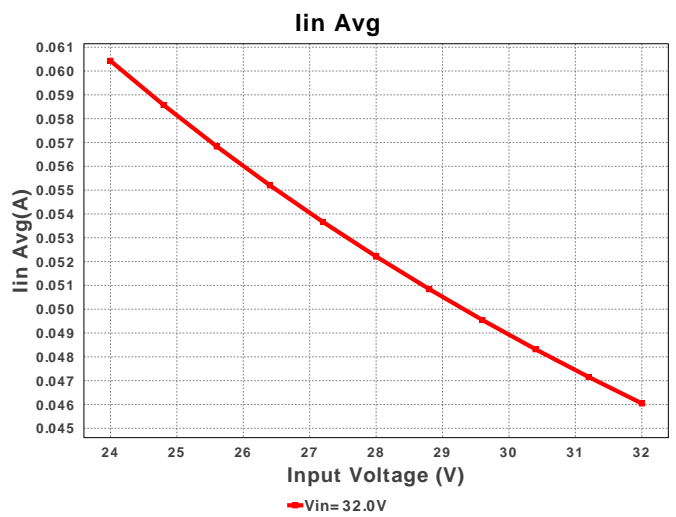
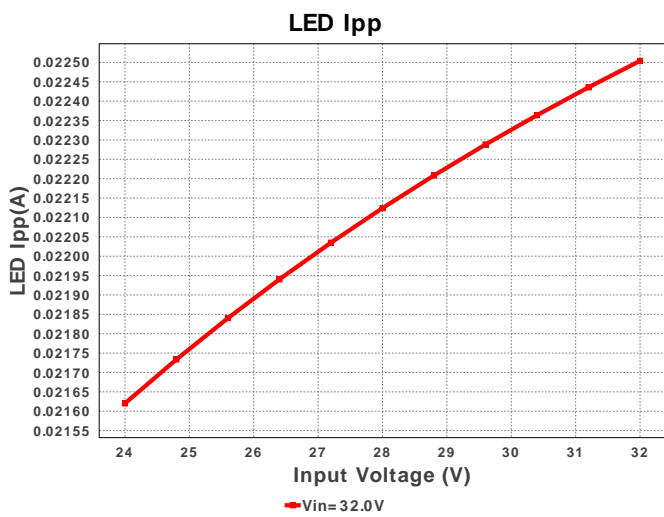
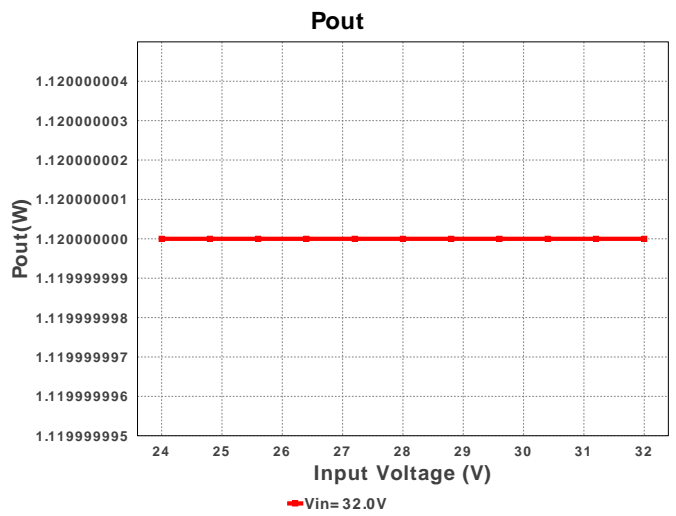
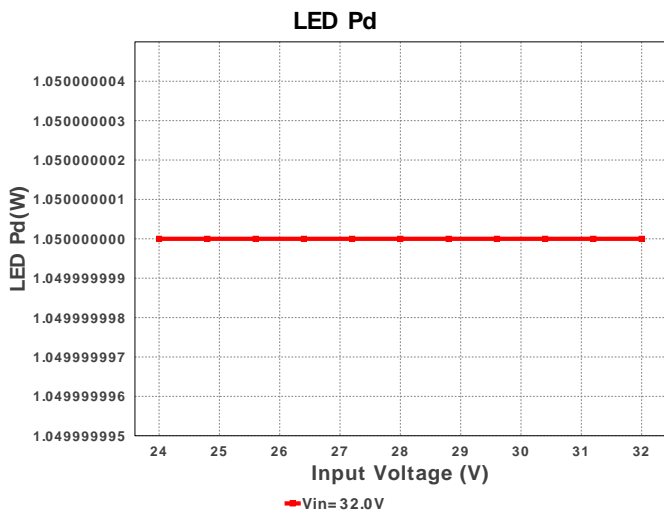
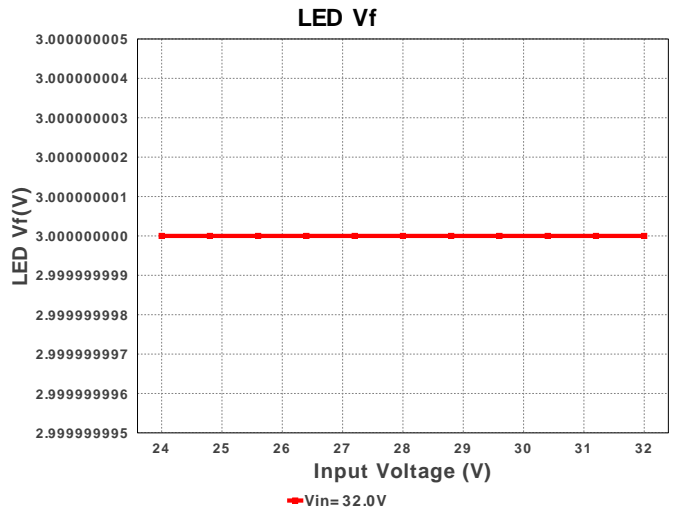
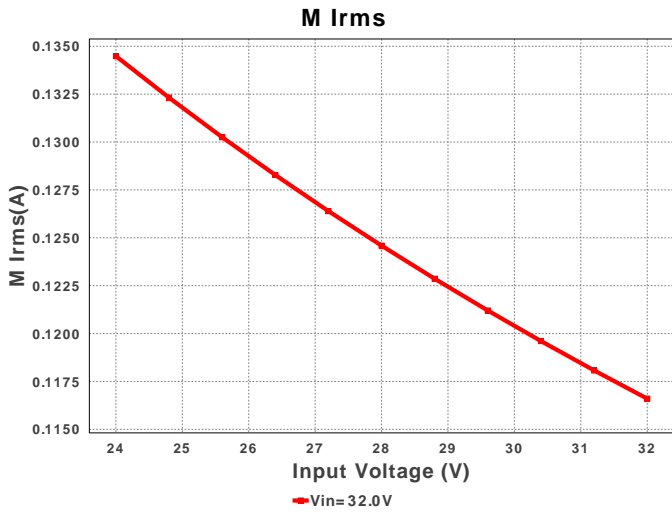

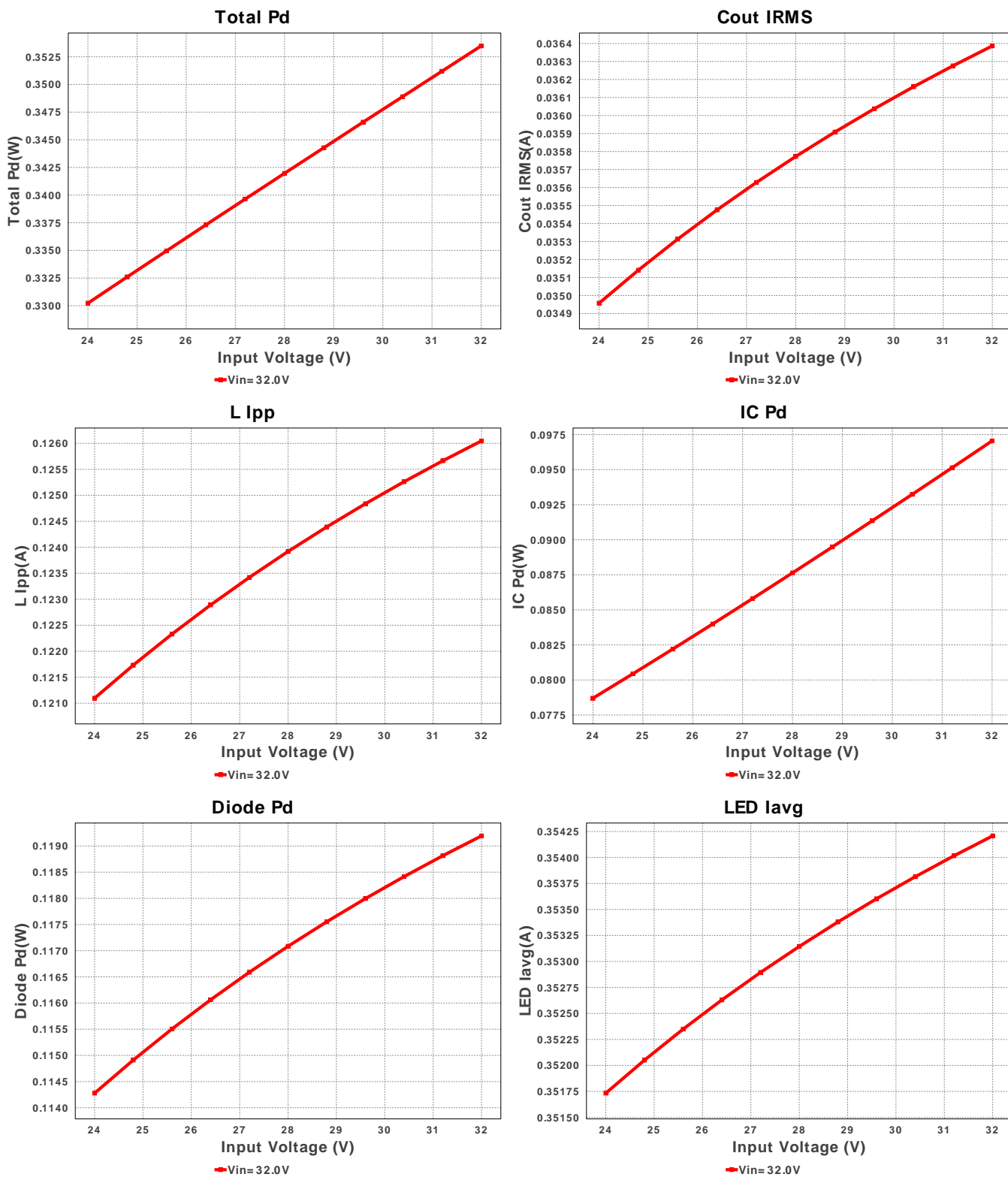

Operating Values

#	Name	Value	Category	Description
1.	Cin IRMS	107.799 mA	Current	Input capacitor RMS ripple current
2.	Cout IRMS	36.501 mA	Current	Output capacitor RMS ripple current
3.	IC Ipk	433.398 mA	Current	Peak switch current in IC
4.	Iin Avg	46.169 mA	Current	Average input current
5.	L Ipp	126.44 mA	Current	Peak-to-peak inductor ripple current
6.	LED Iavg	354.407 mA	Current	LED Average Current
7.	LED Ipp	22.575 mA	Current	LED Ripple Current
8.	M Irms	116.787 mA	Current	MOSFET RMS current
9.	BOM Count	10	General	Total Design BOM count
10.	FootPrint	269.0 mm ²	General	Total Foot Print Area of BOM components
11.	Frequency	211.333 kHz	General	Switching frequency

#	Name	Value	Category	Description
12.	IC Tolerance	6.0 mV	General	IC Feedback Tolerance
13.	M Vds Act	100.851 mV	General	Voltage drop across the MosFET
14.	Pout	1.12 W	General	Total output power
15.	Total BOM	\$3.25	General	Total BOM Cost
16.	D1 Tj	70.62 degC	Op_Point	D1 junction temperature
17.	Vout OP	3.2 V	Op_Point	Operational Output Voltage
18.	Duty Cycle	11.134 %	Op_point	Duty cycle
19.	Efficiency	75.808 %	Op_point	Steady state efficiency
20.	IC Tj	34.854 degC	Op_point	IC junction temperature
21.	ICThetaJA	50.0 degC/W	Op_point	IC junction-to-ambient thermal resistance
22.	IOUT_OP	350.0 mA	Op_point	Iout operating point
23.	LED Rd	751.057 mOhm	Op_point	LED DynamicResistance
24.	LED Vf	3.0 V	Op_point	Total LED Forward Calculated Voltage
25.	VIN_OP	32.0 V	Op_point	Vin operating point
26.	Cin Pd	34.862 µW	Power	Input capacitor power dissipation
27.	Cout Pd	3.997 µW	Power	Output capacitor power dissipation
28.	Diode Pd	123.092 mW	Power	Diode power dissipation
29.	IC Pd	97.084 mW	Power	IC power dissipation
30.	L Pd	53.9 mW	Power	Inductor power dissipation
31.	LED Pd	1.05 W	Power	LED Power Dissipation
32.	Rsense Pd	83.3 mW	Power	LED Power Dissipation
33.	Total Pd	357.415 mW	Power	Total Power Dissipation

Design Inputs

#	Name	Value	Description
1.	Iout	350.0 m	Maximum Output Current
2.	Iout1	350.0 m	Output Current #1
3.	VinMax	32.0	Maximum input voltage
4.	VinMin	24.0	Minimum input voltage
5.	Vout	3.0	Output Voltage
6.	Vout1	3.0	Output Voltage #1
7.	application	LED_DRIVER	LED Application
8.	base_pn	LM3402	Texas Instruments Base Part Number
9.	isLEDArchitect	N	LED Architect Project
10.	ledparallel	1.0	Number of LED in parallel
11.	ledpartnumber	XPGWHT- L1-0000-00G51	LED Part number
12.	ledseries	1.0	Number of LED in series
13.	line_fsw	60.0	AC Line Frequency
14.	source	DC	Input Source Type
15.	ta	30.0	Ambient temperature

Design Assistance

1. LM3402 Product Folder : <http://www.ti.com/product/LM3402> : contains the data sheet and other resources.

Texas Instruments' WEBENCH simulation tools attempt to recreate the performance of a substantially equivalent physical implementation of the design. Simulations are created using Texas Instruments' published specifications as well as the published specifications of other device manufacturers. While Texas Instruments does update this information periodically, this information may not be current at the time the simulation is built. Texas Instruments does not warrant the accuracy or completeness of the specifications or any information contained therein. Texas Instruments does not warrant that any designs or recommended parts will meet the specifications you entered, will be suitable for your application or fit for any particular purpose, or will operate as shown in the simulation in a physical implementation. Texas Instruments does not warrant that the designs are production worthy.

You should completely validate and test your design implementation to confirm the system functionality for your application prior to production.

Use of Texas Instruments' WEBENCH simulation tools is subject to [Texas Instruments' Site Terms and Conditions of Use](#). Prototype boards based on WEBENCH created designs are provided AS IS without warranty of any kind for evaluation and testing purposes and are subject to the terms of the [Evaluation License Agreement](#).