

# PVCC\_4.5V TO 26V

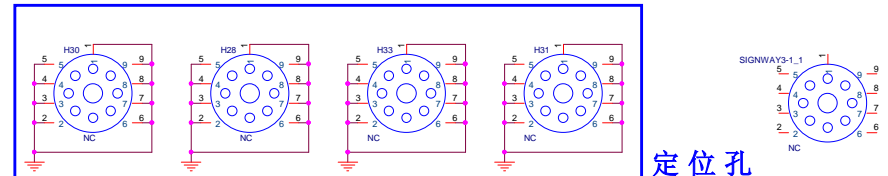
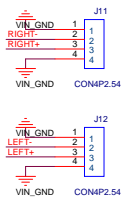
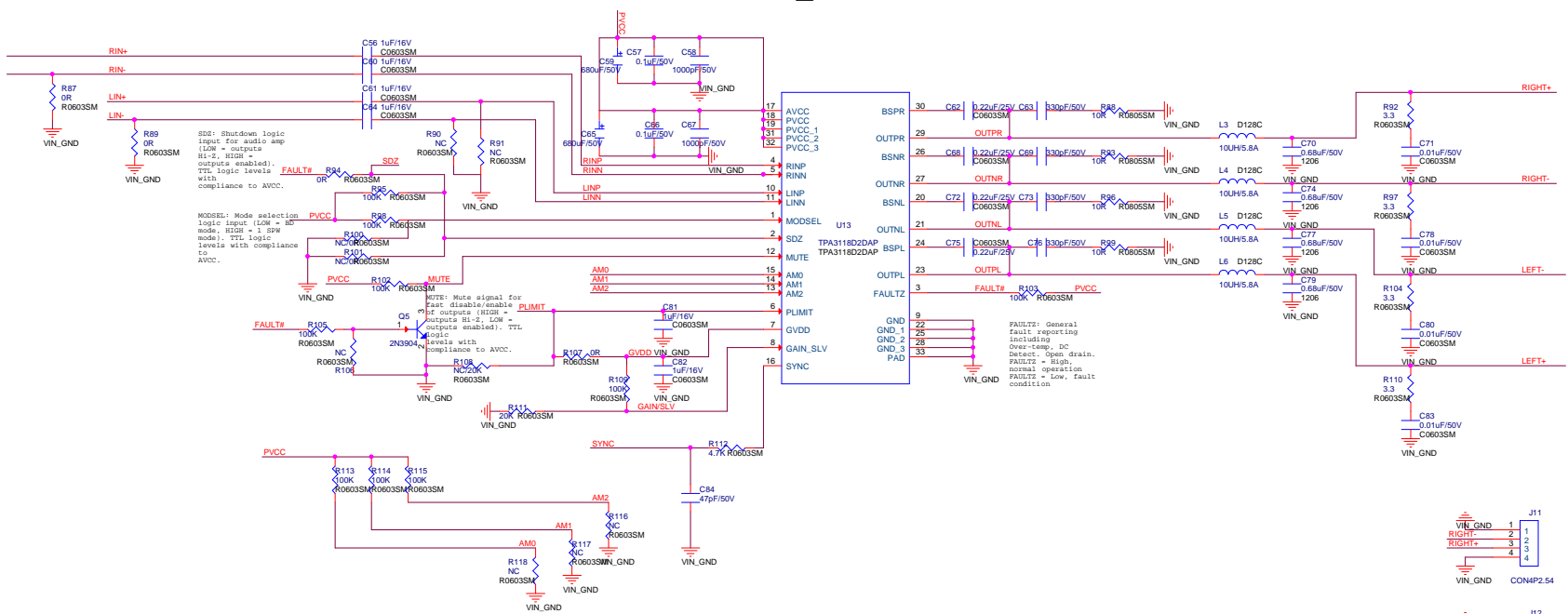
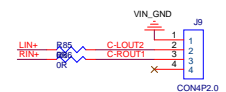

Title	<Title>		
Size	C	Document Number	<Doc>
Date:	Friday, May 20, 2016	Sheet	4 of 4