

UCD3138

用于隔离式电源的高度集成数字控制器

Data Manual



PRODUCTION DATA information is current as of publication date.
Products conform to specifications per the terms of the Texas
Instruments standard warranty. Production processing does not
necessarily include testing of all parameters.

Literature Number: ZHCS429B
March 2012–Revised July 2012

内容

1	介绍	6
	1.1 特性	6
	1.2 应用范围	7
2	概览	7
	2.1 说明	7
	2.2 订购信息	8
	2.3 产品选择矩阵	8
	2.4 功能方框图	9
	2.5 UCD3138 64 QFN – 引脚分配	10
	2.6 引脚功能	11
	2.7 UCD3138 40 QFN – 引脚分配	13
	2.8 引脚功能	14
3	Electrical Specifications	15
	3.1 ABSOLUTE MAXIMUM RATINGS	15
	3.2 THERMAL INFORMATION	15
	3.3 RECOMMENDED OPERATING CONDITIONS	15
	3.4 ELECTRICAL CHARACTERISTICS	16
	3.5 PMBus/SMBus/I ² C Timing	19
	3.6 Power On Reset (POR) / Brown Out Reset (BOR)	20
	3.7 Typical Clock Gating Power Savings	21
	3.8 Typical Temperature Characteristics	22
4	Functional Overview	23
	4.1 ARM Processor	23
	4.2 Memory	23
	4.2.1 CPU Memory Map and Interrupts	23
	4.2.1.1 Memory Map (After Reset Operation)	23
	4.2.1.2 Memory Map (Normal Operation)	24
	4.2.1.3 Memory Map (System and Peripherals Blocks)	24
	4.2.2 Boot ROM	24
	4.2.3 Customer Boot Program	25
	4.2.4 Flash Management	25
	4.3 System Module	25
	4.3.1 Address Decoder (DEC)	25
	4.3.2 Memory Management Controller (MMC)	25
	4.3.3 System Management (SYS)	25
	4.3.4 Central Interrupt Module (CIM)	26
	4.4 Peripherals	27
	4.4.1 Digital Power Peripherals	27
	4.4.1.1 Front End	27
	4.4.1.2 DPWM Module	28
	4.4.1.3 DPWM Events	29
	4.4.1.4 High Resolution DPWM	31
	4.4.1.5 Over Sampling	31
	4.4.1.6 DPWM Interrupt Generation	31
	4.4.1.7 DPWM Interrupt Scaling/Range	31
	4.5 DPWM Modes of Operation	32
	4.5.1 Normal Mode	32
	4.6 Phase Shifting	34
	4.7 DPWM Multiple Output Mode	35
	4.8 DPWM Resonant Mode	36
	4.9 Triangular Mode	38

4.10	Leading Edge Mode	39
4.11	Sync FET Ramp and IDE Calculation	41
4.12	Automatic Mode Switching	41
4.12.1	Phase Shifted Full Bridge Example	41
4.12.2	LLC Example	42
4.12.3	Mechanism for Automatic Mode Switching	44
4.13	DPWMC, Edge Generation, IntraMux	45
4.14	Filter	46
4.14.1	Loop Multiplexer	48
4.14.2	Fault Multiplexer	49
4.15	Communication Ports	51
4.15.1	SCI (UART) Serial Communication Interface	51
4.15.2	PMBUS	51
4.15.3	General Purpose ADC12	52
4.15.4	Timers	53
4.15.4.1	24-bit PWM Timer	53
4.15.4.2	16-Bit PWM Timers	54
4.15.4.3	Watchdog Timer	54
4.16	Miscellaneous Analog	54
4.17	Package ID Information	54
4.18	Brownout	54
4.19	Global I/O	55
4.20	Temperature Sensor Control	56
4.21	I/O Mux Control	56
4.21.1	JTAG Use for I/O and JTAG Security	57
4.22	Current Sharing Control	57
4.23	Temperature Reference	58
5	IC Grounding and Layout Recommendations	59
6	Tools and Documentation	60
7	References	62
	Revision History	63

图片列表

3-1	I ² C/SMBus/PMBus Timing Diagram	20
3-2	Bus Timing in Extended Mode.....	20
3-3	Power On Reset (POR) / Brown Out Reset (BOR)	20
3-4	EADC LSB Size with 4X Gain (mV) vs. Temperature	22
3-5	ADC12 Measurement Temperature Sensor Voltage vs. Temperature.....	22
3-6	ADC12 2.5-V Reference vs. Temperature	22
3-7	ADC12 Temperature Sensor Measurement Error vs. Temperature	22
3-8	UCD3138 Oscillator Frequency (2MHz Reference, Divided Down from 250MHz) vs. Temperature.....	22
4-1	Input Stage of EADC Module	28
4-2	Front End Module	28
4-3	Secondary-Referenced Phase-Shifted Full Bridge Control With Synchronous Rectification	42
4-4	Secondary-Referenced Half-Bridge Resonant LLC Control With Synchronous Rectification	43
4-5	Fault Mux Block Diagram	51
4-6	PMBus Address Detection Method	52
4-7	ADC12 Control Block Diagram	53
4-8	Internal Temp Sensor.....	56
4-9	Simplified Current Sharing Circuitry	57

图表列表

2-1	引脚功能	11
2-2	引脚功能	14
3-1	I ² C/SMBus/PMBus Timing Characteristics	19
4-1	Interrupt Priority Table	26
4-2	DPWM Interrupt Divide Ratio	31

用于隔离式电源的高度集成数字控制器

查询样品: [UCD3138](#)

1 介绍

1.1 特性

- 可对多达 **3** 个独立式反馈环路的数字控制
 - 专用的基于 **PID** 的硬件
 - 可配置 **2 极 / 2 零**
 - 非线性控制
- 高达 **16MHz** 的误差模数转换器 (**EADC**)
 - 可配置低至 **1mV/LSB** 的分辨率
 - 自动分辨率选择
 - 高达 **8 倍** 过度采样
 - 基于硬件的取平均值操作 (高达 **8x**)
 - **14 位** 高效数模转换器 (**DAC**)
 - 自适应采样触发器定位
- 高达 **8** 个高分辨率数字脉宽已调制 (**DPWM**) 输出
 - 脉宽分辨率为 **250ps**
 - 频率分辨率为 **4ns**
 - 相位分辨率为 **4ns**
 - 输出间的可调相移
 - 配对间的可调死区
 - 逐周期占空比匹配
 - 高达 **2MHz** 开关频率
- 可配置的 **PWM** 边沿运动
 - 后缘调制
 - 前缘调制
 - 三角调制
- 可配置的反馈控制
 - 电压模式
 - 平均电流模式
 - 峰值电流模式控制
 - 恒定电流
 - 恒定电源
- 可配置调制方法
 - 频率调制
 - 相移调制
 - 脉宽调制
- 快速、自动和平滑模式开关
 - 频率调制和 **PWM**
 - 相移调制和 **PWM**
- 高效和轻负载管理
 - 突发模式
 - 理想的二极管仿真
 - 同步镇流器软打开/关闭
 - 低集成电路 (**IC**) 待机功率
- 具有和不具有预偏置的软启动/停止
- 快速输入电压前馈硬件
- 初级侧电压感应
- 铜走线电流感应
- 针对非峰值电流模式控制应用的磁通和相位电流均衡
- 电流共享总线支持
 - 模拟平均
 - 主/从
- 特有丰富的故障保护选项
 - **7** 个高速模拟比较器
 - 逐周期电流限制
 - 可编程故障计数
 - 外部故障输入
 - **10** 数字位比较器
 - 可编程消隐时间
- 多重 **UCD3138** 器件间的 **DPWM** 波形同步
- **14** 通道, **12** 位, **267kbps** 通用模数转换器 (**ADC**), 此转换器带有集成的
 - 可编程平均滤波器
 - 双采样保持
- 内部温度传感器
- 完全可编程高性能 **31.25MHz**, **32** 位 **ARM7TDMI-S** 处理器
 - **32k** 字节 (**kB**) 编程闪存
 - 具有纠错码 (**ECC**) 的 **2kB** 数据闪存
 - **4kB** 数据 **RAM**
 - **4kB** 启动 **ROM** 通过 **I²C** 或者 **UART** 在场中启用固件引导-载入
- 通信外设
 - **I²C** / 电源管理总线 (**PMBus**)
 - 在 **UCD3138RGC** (**40** 引脚四方扁平无引线 (**QFN**)) 上有 **2** 个 **UART**
 - 在 **UCD3138RHA** (**40** 引脚 **QFN**) 上有 **1** 个 **UART**
- **JTAG** 调试端口
- 具有可选输入引脚的定时器捕捉
- 多达 **5** 个附加的通用定时器
- 内置安全装置: **BOD** 和 **POR**
- **64** 引脚 **QFN** 和 **40** 引脚 **QFN** 封装
- 运行温度: **-40°C** 至 **125°C**



Please be aware that an important notice concerning availability, standard warranty, and use in critical applications of Texas Instruments semiconductor products and disclaimers thereto appears at the end of this data sheet.

- 支持整合数字电源设计图形用户界面 (GUI)

1.2 应用范围

- 电源和电信整流器
- 功率因数校正
- 隔离的 **dc-dc** 模块

2 概览

2.1 说明

UCD3138 是一款德州仪器 (TI) 数字电源控制器，此控制器在一个单一芯片解决方案内提供高集成度和出色性能。UCD3138 灵活的特性使得此器件适合于品种繁多的电源转换应用。此外，器件内的多重外设已进行了专门优化以提升 ac/dc 和隔离的 dc/dc 应用性能并减少 IT 和网络基础设施空间内的解决方案组件数量。

UCD3138 是一款完全可编程解决方案，此方案可以使用户对他们的应用进行完全控制，以及很多的区分他们的解决问题的能力。与此同时，TI 致力于通过提供同类产品最佳的开发工具来简化我们用户的开发工作，这些开发工具包括应用固件、Code Composer Studio™ 软件开发环境、和 TI 的电源开发 GUI，这使得用户能够配置和监控关键系统参数。

在 UCD3138 控制器的内核上是数字控制环路外设，也被称为数字电源外设 (DPP)。每个 DPP 执行一个高速数字控制环路，此环路由一个专用误差模数转换器 (EADC)、一个基于 2 极 - 2 零数字补偿器的 PID 和具有 250ps 脉宽分辨率的 DPWM 输出组成。此器件还包含一个 12 位，267ksps 通用 ADC，此 ADC 具有多达 14 个通道、定时器、中断控制、JTAG 调试和 PMBus 以及 UART 通信端口。此器件基于一个执行实时监控、配置外设且管理通信的 ARM7TDMI-S 精简指令集微控制器。ARM 微控制器从可编程闪存存储器以及片载 RAM 和 ROM 里执行它的程序。

除了 FDPP，特定电源管理外设已被添加以便在全部运行范围内启用高效、针对增加的功率密度的高集成度、可靠性、和最低总体系统成本以及支持最广泛控制体系和拓扑数量的高灵活性。此类外设包括：轻负载突发模式、同步整流、LLC 和移相全桥模式开关、输入电压前馈、铜走线电流感应、理想的二极管仿真、恒定电流恒定功率控制、同步整流软打开和关闭、峰值电流控制模式、磁通均衡、二次侧输入电压感应、高分辨率电流共享、具有预偏置电压的硬件可配置软启动、以及几个其它特性。已经针对电压模式和峰值电流模式、受控相位迁移全桥、单双相位功率因数校正 (PFC)、无桥 PFC、硬开关全桥和半桥、以及 LLC 半桥和全桥进行了拓扑支持优化。

2.2 订购信息

器件型号	引脚总数	封装	电源	顶端标记	运行温度范围, T _A
UCD3138RGCT	64	QFN	250 (小卷带)	UCD3138	-40°C 至 125°C
UCD3138RGCR	64	QFN	2000 (大卷带)	UCD3138	-40°C 至 125°C
UCD3138RHAT	40	QFN	250 (小卷带)	UCD3138	-40°C 至 125°C
UCD3138RHAR	40	QFN	2500 (大卷带)	UCD3138	-40°C 至 125°C

2.3 产品选择矩阵

功能 :	UCD3138 64 引脚	UCD3138 40 引脚
ARM7TDMI-S 内核处理器	31.25MHz	31.25MHz
高分辨率数字脉宽调制 (DPWM) 输出 (250ps 分辨率)	8	8
高速独立反馈环路数量 (# 经调节的输出电压)	3	3
12 位, 267ksps, 通用 ADC 通道	14	7
ADC 输出上的数字比较器	4	4
闪存存储器 (程序)	32KB	32KB
闪存存储器 (数据)	2KB	2KB
闪存安全	√	√
RAM	4KB	4KB
DPWM 开关频率	高达 2MHz	高达 2MHz
可编程故障输出	4	1 + 2 ⁽¹⁾
具有逐周期电流限制的高速模拟比较器	7 ⁽²⁾	6 ⁽²⁾
UART (SCI)	2	1 ⁽¹⁾
电源管理总线 (PMBus)	√	√
定时器	4 (16 位) 和 1 (24 位)	4 (16 位) 和 1 (24 位)
定时器 PWM 输出	2	1
定时器捕捉输入	1	1 ⁽¹⁾
安全装置	√	√
片载振荡器	√	√
加电复位和欠压复位	√	√
JTAG	√	√
提供的封装	64 引脚 QFN 封装 (9mm x 9mm)	40 引脚 QFN 封装 (6mm x 6mm)
同步输入和同步输出功能	√	√
全部 GPIO (包括所有具有复用功能的引脚, 例如 DPWM, 故障输入, SCI 等)	30	18
外部中断	1	0

(1) 这个数字代表一个可通过固件进行编程的替代引脚。细节请见《UCD3138 数字电源外设程序设计者手册》。

(2) 为了使简单过压保护 (OVP) 和欠压保护 (UVP) 连接更加便捷, 比较器 B 和 C 被连接至 AD03 引脚。

2.4 功能方框图

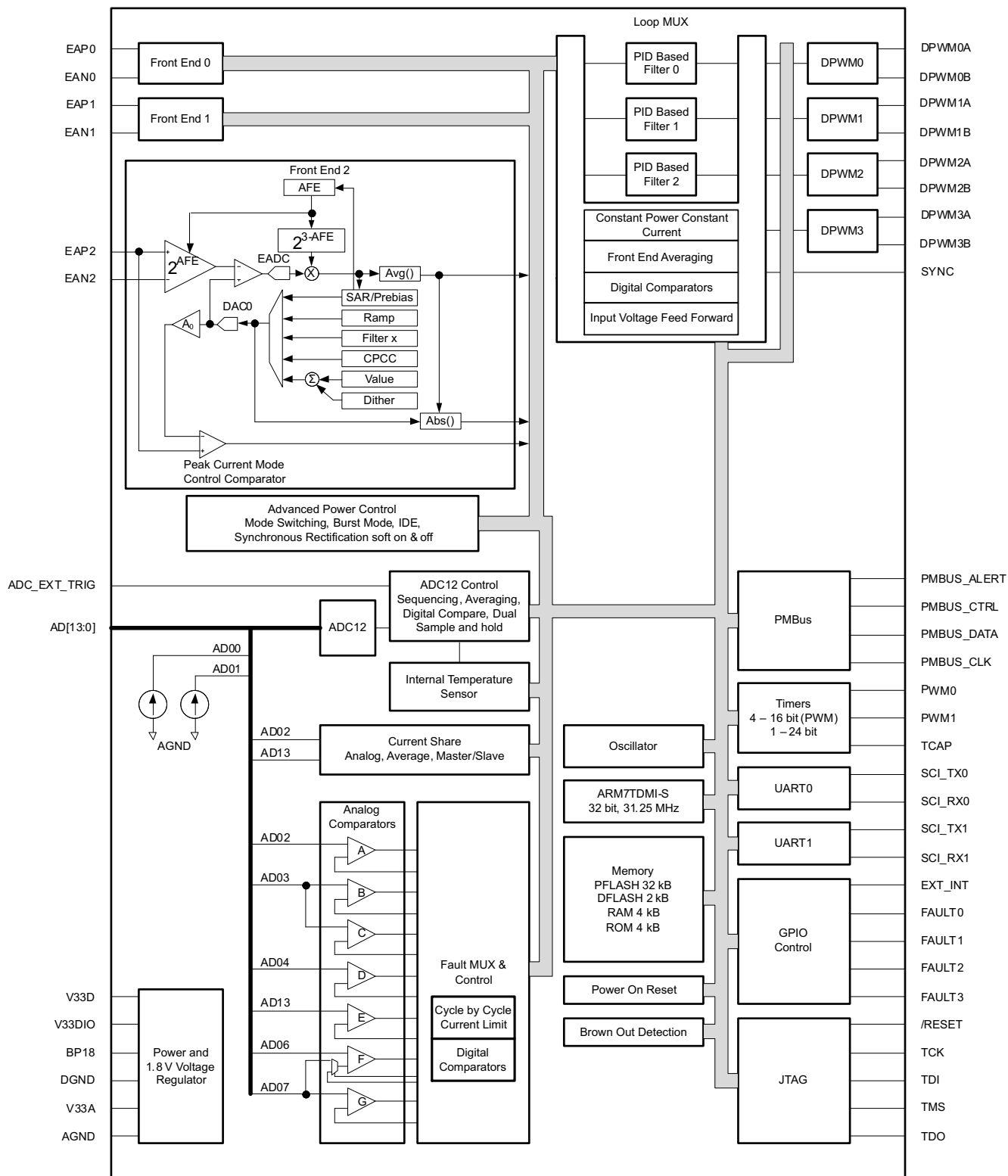

2.5 UCD3138 64 QFN – 引脚分配

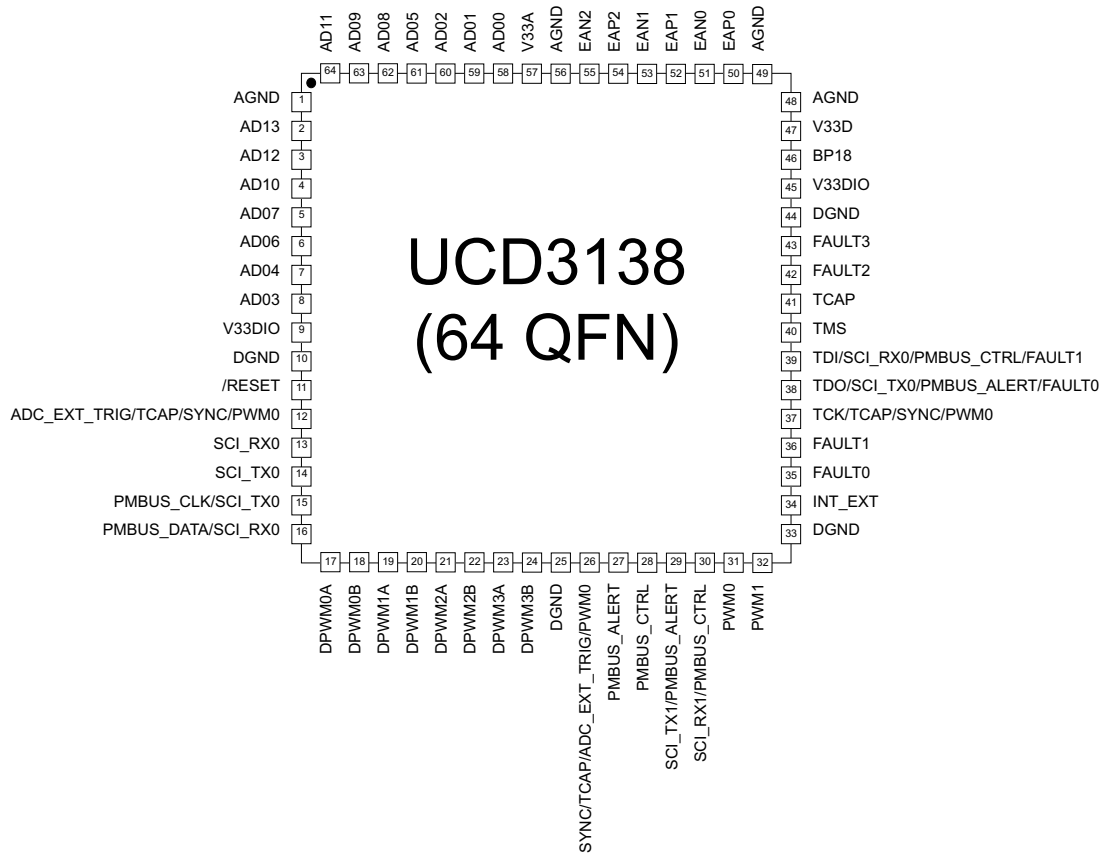

2.6 引脚功能

下面的表格中说明了附件引脚的功能性。

表 2-1. 引脚功能

引脚	名称	主分配	替代分配			可配置 为一个 GPIO 吗?
			编号1	编号2	编号3	
1	AGND	模拟接地				
2	AD13	12 位 ADC, 通道 13, 比较器 E, I-共享	数模转换器 (DAC) 输出			
3	AD12	12 位 ADC、通道 12				
4	AD10	12 位 ADC, 通道 10				
5	AD07	12 位 ADC, 通道 7, 连接至比较器 F 并且以比较器 G 为基准	DAC 输出			
6	AD06	12 位 ADC, 通道 6, 连接至比较器 F	DAC 输出			
7	AD04	12 位 ADC, 通道 4, 连接至比较器 D	DAC 输出			
8	AD03	12 位 ADC, 通道 3, 连接至比较器 B 和 C				
9	V33DIO	数字 I/O 3.3V 内核电源				
10	数字接地 (DGND)	数字接地				
11	复位	器件复位输入、低电平有效				
12	ADC_EXT_TRIG	ADC 转换外部触发器输入	TCAP	SYNC	PWM0	支持
13	SCI_RX0	SCI RX 0				支持
14	SCI_TX0	SCI TX 0				支持
15	PMBUS_CLK	PMBUS 时钟 (开漏)	SCI TX 0			支持
16	PMBUS_DATA	PMBus 数据 (开漏)	SCI RX 0			支持
17	DPWM0A	DPWM 0A 输出				支持
18	DPWM0B	DPWM 0B 输出				支持
19	DPWM1A	DPWM 1A 输出				支持
20	DPWM1B	DPWM 1B 输出				支持
21	DPWM2A	DPWM 2A 输出				支持
22	DPWM2B	DPWM 2B 输出				支持
23	DPWM3A	DPWM 3A 输出				支持
24	DPWM3B	DPWM 3B 输出				支持
25	数字接地 (DGND)	数字接地				
26	SYNC	DPWM 同步引脚	TCAP	ADC_EXT_TRIG	PWM0	支持
27	PMBUS_ALERT	PMBus 警报 (开漏)				支持
28	PMBUS_CTRL	PMBUS 控制 (开漏)				支持
29	SCI_TX1	SCI_TX1	PMBUS_ALERT			支持
30	SCI_RX1	SCI RX 1	PMBUS_CTRL			支持
31	PWM0	通用 PWM 0				支持
32	PWM1	通用 PWM 1				支持
33	数字接地 (DGND)	数字接地				
34	INT_EXT	外部中断				支持
35	FAULT0	外部故障输入 0				支持
36	FAULT1	外部故障输入 1				支持
37	TCK	JTAG TCK	TCAP	SYNC	PWM0	支持
38	TDO	JTAG TDO	SCI_TX0	电源管理总线_警报 (PMBUS_ALERT)	FAULT0	支持
39	TDI	JTAG TDI	SCI_RX0	电源管理总线_控制 (PMBUS_CTRL)	FAULT1	支持
40	TMS	JTAG TMS				支持

表 2-1. 引脚功能 (continued)

引脚	名称	主分配	替代分配			可配置 为一个 GPIO 吗?
			编号1	编号2	编号3	
41	TCAP	定时器捕捉输入				支持
42	FAULT2	外部故障输入 2				支持
43	FAULT3	外部故障输入 3				支持
44	DGND	数字接地				
45	V33DIO	数字 I/O 3.3V 内核电源				
46	BP 18	1.8V 旁通				
47	V33D	数字 3.3V 内核电源				
48	AGND	基板模拟接地				
49	AGND	模拟接地				
50	EAP0	通道 #0, 差分模拟电压, 正输入				
51	EAN0	通道 #0, 差分模拟电压, 负输入				
52	EAP1	通道 #1, 差分模拟电压, 正输入				
53	EAN1	通道 #1, 差分模拟电压, 负输入				
54	EAP2	通道 #2, 差分模拟电压, 正输入				
55	EAN2	通道 #2, 差分模拟电压, 负输入				
56	AGND	模拟接地				
57	V33A	模拟 3.3V 电源				
58	AD00	12 位 ADC, 通道 0, 被连接至电流源				
59	AD01	12 位 ADC, 通道 1, 被连接至电流源				
60	AD02	12 位 ADC, 通道 2, 被连接至电流源				
61	AD05	12 位 ADC, 通道 5				
62	AD08	12 位 ADC, 通道 8				
63	AD09	12 位 ADC, 通道 9				
64	AD11	12 位 ADC, 通道 11				

2.7 UCD3138 40 QFN – 引脚分配

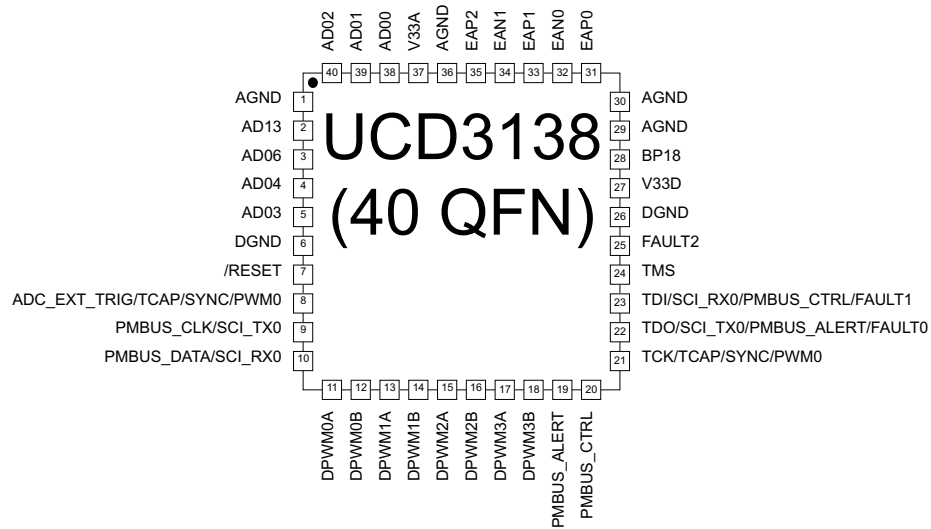

2.8 引脚功能

下面的表格中说明了附件引脚的功能性。

表 2-2. 引脚功能

引脚	名称	主分配	替代分配			可配置 为一个 GPIO 吗?
			编号1	编号2	编号3	
1	AGND	模拟接地				
2	AD13	12 位 ADC, 被连接至比较器 E, I-共享				
3	AD06	12 位 ADC, 通道 6, 被连接至比较器 F				
4	AD04	12 位 ADC, 通道 4, 被连接至比较器 D				
5	AD03	12 位 ADC, 通道 3, 被连接至比较器 B 和 C				
6	DGND	数字接地				
7	复位	器件复位输入、低电平有效				
8	ADC_EXT_TRIG	ADC 转换外部触发器输入	TCAP	SYNC	PWM0	支持
9	PMBUS_CLK	PMBus 时钟 (开漏)	SCI_TX0			支持
10	PMBUS_DATA	PMBus 数据 (开漏)	SCI_RX0			支持
11	DPWM0A	DPWM 0A 输出				支持
12	DPWM0B	DPWM 0B 输出				支持
13	DPWM1A	DPWM 1A 输出				支持
14	DPWM1B	DPWM 1B 输出				支持
15	DPWM2A	DPWM 2A 输出				支持
16	DPWM2B	DPWM 2B 输出				支持
17	DWPM3A	DPWM 3A 输出				支持
18	DPWM3B	DPWM 3B 输出				支持
19	PMBUS_ALERT	PMBus 警报 (开漏)				支持
20	PMBUS_CTRL	PMBUS 控制 (开漏)				支持
21	TCK	JTAG TCK	TCAP	SYNC	PWM0	支持
22	TDO	JTAG TDO	SCI_TX0	PMBUS_A LERT	FAULT0	支持
23	TDI	JTAG TDI	SCI_RX0	PMBUS_C TRL	FAULT1	支持
24	TMS	JTAG TMS				支持
25	FAULT2	外部故障输入 2				支持
26	DGND	数字接地				
27	V33D	数字 3.3V 内核电源				
28	BP 18	1.8V 旁通				
29	AGND	基板模拟接地				
30	AGND	模拟接地				
31	EAP0	通道 #0, 差分模拟电压, 正输入				
32	EAN0	通道 #0, 差分模拟电压, 负输入				
33	EAP1	通道 #1, 差分模拟电压, 正输入				
34	EAN1	通道 #1, 差分模拟电压, 负输入				
35	EAP2	通道 #2, 差分模拟电压, 正输入				
36	AGND	模拟接地				
37	V33A	模拟 3.3V 电源				
38	AD00	12 位 ADC, 通道 0, 被连接至电流源				
39	AD01	12 位 ADC, 通道 1, 被连接至电流源				
40	AD02	12 位 ADC, 通道 2, 被连接至比较器 A, I-共享				

3 Electrical Specifications

3.1 ABSOLUTE MAXIMUM RATINGS ⁽¹⁾

over operating free-air temperature range (unless otherwise noted)

		VALUE		UNIT
		MIN	MAX	
V33D	V33D to DGND	-0.3	3.8	V
V33DIO	V33DIO to DGND	-0.3	3.8	V
V33A	V33A to AGND	-0.3	3.8	V
DGND – AGND	Ground difference	0.3		V
All Pins, excluding AGND ⁽²⁾	Voltage applied to any pin	-0.3	3.8	V
T _{OPT}	Junction Temperature	-40	125	°C
T _{STG}	Storage temperature	-55	150	°C

- (1) Stresses beyond those listed under absolute maximum ratings may cause permanent damage to the device. These are stress ratings only, and functional operation of the device at these or any other conditions beyond those indicated under recommended operating conditions is not implied. Exposure to absolute-maximum-rated conditions for extended periods may affect device reliability.
- (2) Referenced to DGND

3.2 THERMAL INFORMATION

THERMAL METRIC ⁽¹⁾		UCD3138	UCD3138	UNITS
		64 PIN QFN	40 PIN QFN	
θ_{JA}	Junction-to-ambient thermal resistance ⁽²⁾	25.1	31.8	°C/W
θ_{JCTop}	Junction-to-case (top) thermal resistance ⁽³⁾	10.5	18.5	
θ_{JB}	Junction-to-board thermal resistance ⁽⁴⁾	4.6	6.8	
ψ_{JT}	Junction-to-top characterization parameter ⁽⁵⁾	0.2	0.2	
ψ_{JB}	Junction-to-board characterization parameter ⁽⁶⁾	4.6	6.7	
θ_{JCbott}	Junction-to-case (bottom) thermal resistance ⁽⁷⁾	1.2	1.8	

- (1) For more information about traditional and new thermal metrics, see the *IC Package Thermal Metrics* application report, [SPRA953](#)
- (2) 在 JESD51-2a 描述的环境中，按照 JESD51-7 的规定，在一个 JEDEC 标准高 K 电路板上进行仿真，从而获得自然对流条件下的结至环境热阻抗。
- (3) 通过在封装顶部模拟一个冷板测试来获得结至芯片外壳（顶部）的热阻。不存在特定的 JEDEC 标准测试，但可在 ANSI SEMI 标准 G30-88 中找到内容接近的说明。
- (4) 按照 JESD51-8 中的说明，通过在配有用于控制 PCB 温度的环形冷板夹具的环境中进行仿真，以获得结至电路板的热阻。
- (5) 结至顶部的特征参数，(ψ_{JT})，估算真实系统中器件的结温，并使用 JESD51-2a（第 6 章和第 7 章）中描述的程序从仿真数据中提取出该参数以便获得 θ_{JA} 。
- (6) 结至电路板的特征参数，(ψ_{JB})，估算真实系统中器件的结温，并使用 JESD51-2a（第 6 章和第 7 章）中描述的程序从仿真数据中提取出该参数以便获得 θ_{JA} 。
- (7) 通过在外露（电源）焊盘上进行冷板测试仿真来获得结至芯片外壳（底部）热阻。不存在特定的 JEDEC 标准测试，但可在 ANSI SEMI 标准 G30-88 中找到了内容接近的说明。

3.3 RECOMMENDED OPERATING CONDITIONS

over operating free-air temperature range (unless otherwise noted)

		MIN	TYP	MAX	UNIT
V33D	Digital power	3.0	3.3	3.6	V
V33DIO	Digital I/O power	3.0	3.3	3.6	
V33A	Analog power	3.0	3.3	3.6	V
T _J	Junction temperature	-40	-	125	°C

3.4 ELECTRICAL CHARACTERISTICS

V33A = V33D = V33DIO = 3.3V; 1 μ F from BP18 to DGND, T_J = –40°C to 125°C (unless otherwise noted)

PARAMETER		TEST CONDITION	MIN	TYP	MAX	UNIT
SUPPLY CURRENT						
I33A		Measured on V33A. The device is powered up but all ADC12 and EADC sampling is disabled		6.3		mA
I33DIO		All GPIO and communication pins are open		0.35		mA
I33D		ROM program execution		60		mA
I33D		Flash programming in ROM mode			70	mA
I33		The device is in ROM mode with all DPWMs enabled and switching at 2 MHz. The DPWMs are all unloaded.			100	mA
ERROR ADC INPUTS EAP, EAN						
EAP – AGND			–0.15		1.998	V
EAP – EAN			–0.256		1.848	V
Typical error range		AFE = 0	–256		248	mV
EAP – EAN Error voltage digital resolution		AFE = 3	0.8	1	1.20	mV
		AFE = 2	1.7	2	2.30	mV
		AFE = 1	3.55	4	4.45	mV
		AFE = 0	6.90	8	9.10	mV
R _{EA}	Input impedance (See Figure 4-1)	AGND reference	0.5			M Ω
I _{OFFSET}	Input offset current (See Figure 4-1)		–5		5	μ A
EADC Offset		Input voltage = 0 V at AFE = 0	–2		2	LSB
		Input voltage = 0 V at AFE = 1	–2.5		2.5	LSB
		Input voltage = 0 V at AFE = 2	–3		–3	LSB
		Input voltage = 0 V at AFE = 3	–4		4	LSB
Sample Rate					16	MHz
Analog Front End Amplifier Bandwidth				100		MHz
A ₀	Gain	See Figure 4-2		1		V/V
	Minimum output voltage				100	mV
EADC DAC						
DAC range			0		1.6	V
VREF DAC reference resolution		10 bit, No dithering enabled		1.56		mV
VREF DAC reference resolution		With 4 bit dithering enabled		97.6		μ V
INL			–3.0		3.0	LSB
DNL		Does not include MSB transition	–2.1		1.6	LSB
DNL at MSB transition				–1.4		LSB
DAC reference voltage			1.58		1.61	V
τ	Settling Time	From 10% to 90%		250		ns
ADC12						
I _{BIAS}	Bias current for PMBus address pins		9.5		10.5	μ A
Measurement range for voltage monitoring			0		2.5	V
Internal ADC reference voltage		–40°C to 125°C	2.475	2.500	2.525	V
Change in Internal ADC reference from 25°C reference voltage ⁽¹⁾		–40°C to 25°C		–0.4		mV
		25°C to 85°C		–1.8		
		25°C to 125°C		–4.2		

(1) As designed and characterized. Not 100% tested in production.

ELECTRICAL CHARACTERISTICS (continued)

V33A = V33D = V33DIO = 3.3V; 1µF from BP18 to DGND, T_J = –40°C to 125°C (unless otherwise noted)

PARAMETER		TEST CONDITION	MIN	TYP	MAX	UNIT
ADC12 INL integral nonlinearity ⁽¹⁾		ADC_SAMPLINGSEL = 6 for all ADC12 data, 25 °C to 125 °C	+/-2.5			LSB
ADC12 DNL differential nonlinearity ⁽¹⁾			–0.7/+2.5			LSB
ADC Zero Scale Error			–7		7	mV
ADC Full Scale Error			–35		35	mV
Input bias		2.5 V applied to pin			400	nA
Input leakage resistance ⁽¹⁾		ADC_SAMPLINGSEL= 6 or 0		1		MΩ
Input Capacitance ⁽¹⁾				10		pF
ADC single sample conversion time ⁽¹⁾		ADC_SAMPLINGSEL= 6 or 0		3.9		µs
DIGITAL INPUTS/OUTPUTS⁽²⁾⁽³⁾						
V _{OL}	Low-level output voltage ⁽⁴⁾	I _{OH} = 4 mA, V33DIO = 3 V			DGND + 0.25	V
V _{OH}	High-level output voltage ⁽⁴⁾	I _{OH} = –4 mA, V33DIO = 3 V	V33DIO – 0.6			V
V _{IH}	High-level input voltage	V33DIO = 3 V	2.1			V
V _{IL}	Low-level input voltage	V33DIO = 3 V			1.1	V
I _{OH}	Output sinking current				4	mA
I _{OL}	Output sourcing current		–4			mA
SYSTEM PERFORMANCE						
TWD	Watchdog time out range	Total time is: TWD x (WDCTRL.PERIOD+1)	14.6	17	20.5	ms
	Time to disable DPWM output based on active FAULT pin signal	High level on FAULT pin		70		ns
	Processor master clock (MCLK)			31.25		MHz
t _{Delay}	Digital compensator delay ⁽⁵⁾	(1 clock = 32ns)			6	clocks
V _{DD}	Slew minimum VDD slew rate ⁽⁶⁾	VDD slew rate between 2.3 V and 2.9 V	0.25			V/ms
t _(reset)	Pulse width needed at reset ⁽⁶⁾		10			µs
	Retention period of flash content (data retention and program)	T _J = 25°C	100			years
	Program time to erase one page or block in data flash or program flash			20		ms
	Program time to write one word in data flash or program flash			20		µs
f _(PCLK)	Internal oscillator frequency		240	250	260	MHz
	Sync-in/sync-out pulse width	Sync pin		256		ns
	Flash Read			1		MCLKs
	Flash Write			20		µs
I _{SHARE}	Current share current source (See Figure 4-9)		238		259	µA
R _{SHARE}	Current share resistor (See Figure 4-9)		9.75		10.3	kΩ
POWER ON RESET AND BROWN OUT (V33D pin, See Figure 3-3)						
V _{GH}		Voltage good High		2.7		V
V _{GL}		Voltage good Low		2.5		V
V _{res}		Voltage at which IReset signal is valid		0.8		V

(2) DPWM outputs are low after reset. Other GPIO pins are configured as inputs after reset.

(3) On the 40 pin package V33DIO is connected to V33D internally.

(4) The maximum total current, I_{OHmax} and I_{OLmax} for all outputs combined, should not exceed 12 mA to hold the maximum voltage drop specified. Maximum sink current per pin = –6 mA at V_{OL}; maximum source current per pin = 6 mA at V_{OH}.

(5) Time from close of error ADC sample window to time when digitally calculated control effort (duty cycle) is available. This delay, which has no variation associated with it, must be accounted for when calculating the system dynamic response.

(6) As designed and characterized. Not 100% tested in production.

ELECTRICAL CHARACTERISTICS (continued)V33A = V33D = V33DIO = 3.3V; 1 μ F from BP18 to DGND, T_J = –40°C to 125°C (unless otherwise noted)

PARAMETER		TEST CONDITION	MIN	TYP	MAX	UNIT
T _{POR}		Time delay after Power is good or RESET* relinquished		1		ms
	Brownout	Internal signal warning of brownout conditions		2.9		V
TEMPERATURE SENSOR⁽⁷⁾						
V _{TEMP}		Voltage range of sensor	1.46		2.44	V
	Voltage resolution	Volts/°C		5.9		mV/°C
	Temperature resolution	Degree C per bit		0.1034		°C/LSB
	Accuracy ⁽⁷⁾⁽⁸⁾	–40°C to 125°C	–10	±5	10	°C
	Temperature range	–40°C to 125°C	–40		125	°C
I _{TEMP}		Current draw of sensor when active		30		μ A
T _{ON}		Turn on time / settling time of sensor		100		μ s
V _{AMB}	Ambient temperature	Trimmed 25°C reading		1.85		V
ANALOG COMPARATOR						
DAC	Reference DAC Range		0		2.5	V
	Reference Voltage		2.478	2.5	2.513	V
	Bits			7		bits
	INL ⁽⁷⁾		–0.42		0.21	LSB
	DNL ⁽⁷⁾		0.06		0.12	LSB
	Offset		–5.5		19.5	mV
	Time to disable DPWM output based on 0 V to 2.5 V step input on the analog comparator. ⁽⁹⁾				150	ns
	Reference DAC buffered output load ⁽¹⁰⁾		0.5		1	mA
	Buffer offset (–0.5 mA)		4.6		8.3	mV
	Buffer offset (1.0 mA)		–0.05		17	mV

(7) Characterized by design and not production tested.

(8) Ambient temperature offset value should be used from the TEMPSENCTRL register to meet accuracy.

(9) As designed and characterized. Not 100% tested in production.

(10) Available from reference DACs for comparators D, E, F and G.

3.5 PMBus/SMBus/I²C Timing

The timing characteristics and timing diagram for the communications interface that supports I²C, SMBus, and PMBus in Slave or Master mode are shown in Table 3-1, Figure 3-1, and Figure 3-2. The numbers in Table 3-1 are for 400 kHz operating frequency. However, the device supports all three speeds, standard (100 kHz), fast (400 kHz), and fast mode plus (1 MHz).

Table 3-1. I²C/SMBus/PMBus Timing Characteristics

PARAMETER	TEST CONDITIONS	MIN	TYP	MAX	UNIT
Typical values at T _A = 25°C and VCC = 3.3 V (unless otherwise noted)					
f _{SMB}	SMBus/PMBus operating frequency	Slave mode, SMBC 50% duty cycle	100	1000	kHz
f _{I2C}	I ² C operating frequency	Slave mode, SCL 50% duty cycle	100	1000	kHz
t _(BUF)	Bus free time between start and stop		1.3		ms
t _(HD:STA)	Hold time after (repeated) start		0.6		ms
t _(SU:STA)	Repeated start setup time		0.6		ms
t _(SU:STO)	Stop setup time		0.6		ms
t _(HD:DAT)	Data hold time	Receive mode	0		ns
t _(SU:DAT)	Data setup time		100		ns
t _(TIMEOUT)	Error signal/detect ⁽¹⁾			35	ms
t _(LOW)	Clock low period		1.3		ms
t _(HIGH)	Clock high period ⁽²⁾		0.6		ms
t _(LOW:SEXT)	Cumulative clock low slave extend time ⁽³⁾			25	ms
t _f	Clock/data fall time	Rise time t _r = (V _{ILmax} - 0.15) to (V _{IHmin} + 0.15)	20 + 0.1 Cb ⁽⁴⁾	300	ns
t _r	Clock/data rise time	Fall time t _f = 0.9 VDD to (V _{ILmax} - 0.15)	20 + 0.1 Cb ⁽⁴⁾	300	ns
C _b	Total capacitance of one bus line			400	pF

- (1) The device times out when any clock low exceeds t_(TIMEOUT).
- (2) t_(HIGH), Max, is the minimum bus idle time. SMBC = SMBD = 1 for t > 50 ms causes reset of any transaction that is in progress. This specification is valid when the NC_SMB control bit remains in the default cleared state (CLK[0] = 0).
- (3) t_(LOW:SEXT) is the cumulative time a slave device is allowed to extend the clock cycles in one message from initial start to the stop.
- (4) C_b (pF)

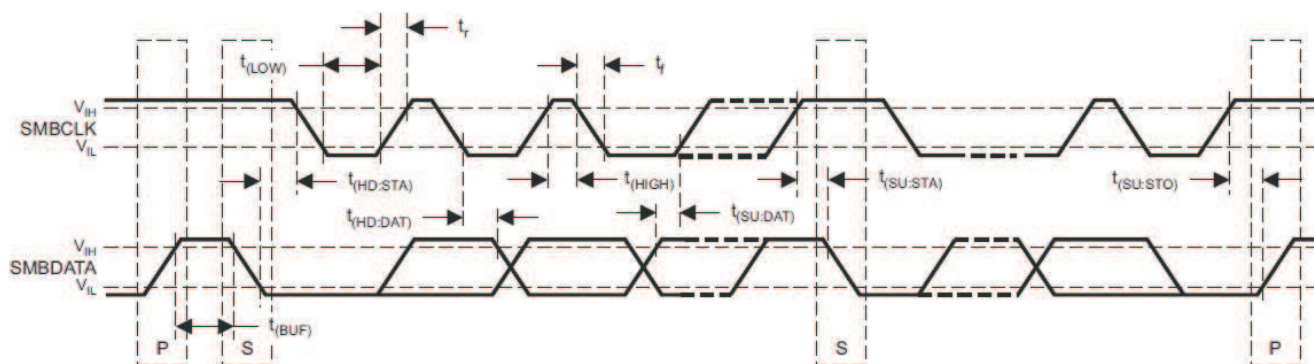

Figure 3-1. I²C/SMBus/PMBus Timing Diagram

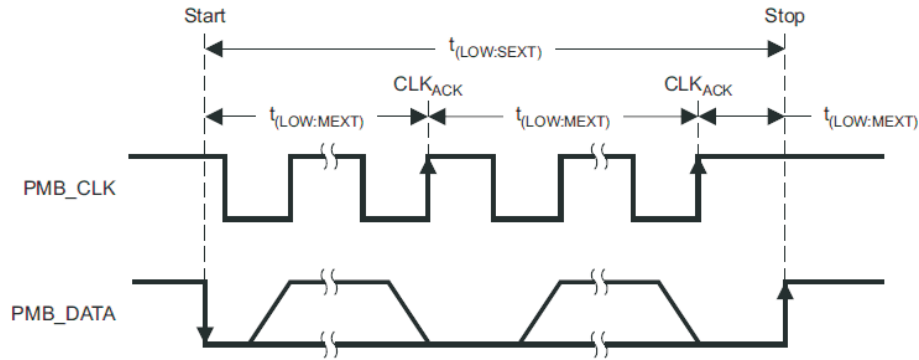

Figure 3-2. Bus Timing in Extended Mode

3.6 Power On Reset (POR) / Brown Out Reset (BOR)

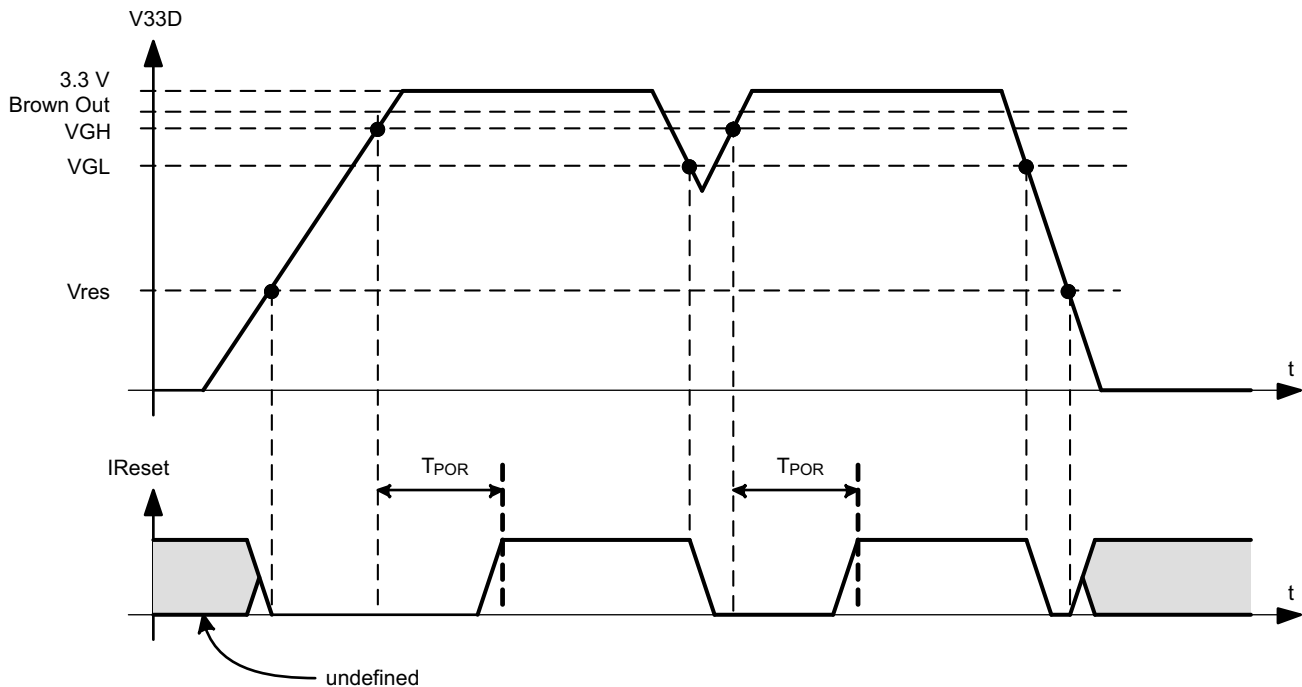
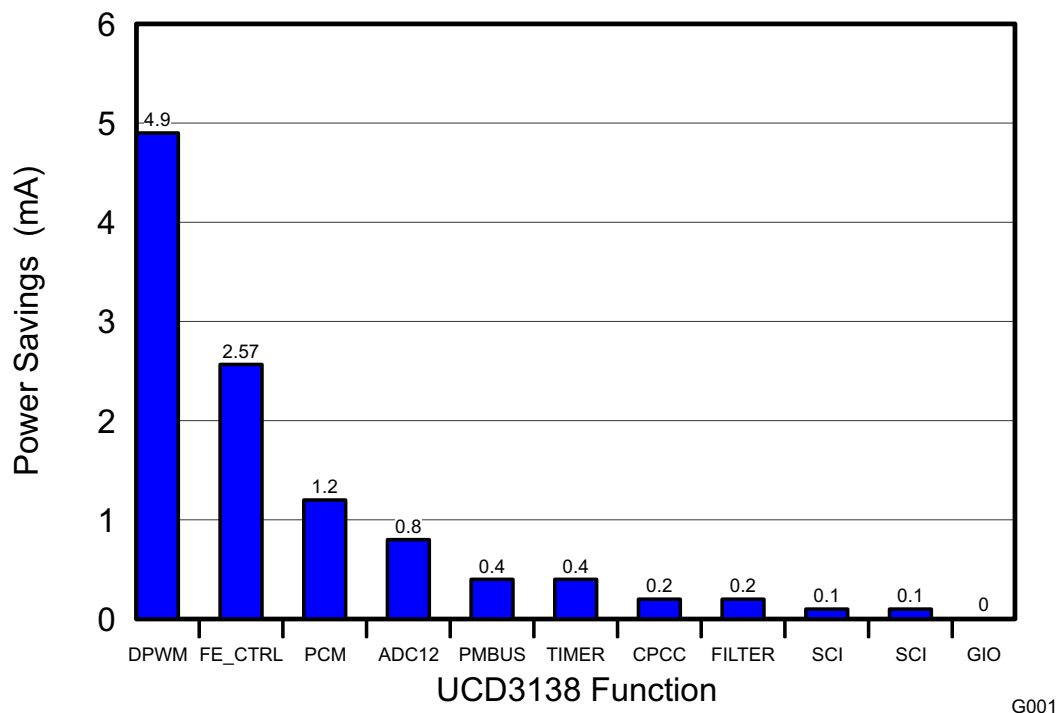

Figure 3-3. Power On Reset (POR) / Brown Out Reset (BOR)

- V_{GH}** – This is the V_{33D} threshold where the internal power is declared good. The UCD3138 comes out of reset when above this threshold.
- V_{GL}** – This is the V_{33D} threshold where the internal power is declared bad. The device goes into reset when below this threshold.
- V_{res}** – This is the V_{33D} threshold where the internal reset signal is no longer valid. Below this threshold the device is in an indeterminate state.
- I_{Reset}** – This is the internal reset signal. When low, the device is held in reset. This is equivalent to holding the reset pin on the IC high.
- T_{POR}** – The time delay from when V_{GH} is exceeded to when the device comes out of reset.
- Brown Out** – This is the V_{33D} voltage threshold at which the device sets the brown out status bit. In addition an interrupt can be triggered if enabled.

3.7 Typical Clock Gating Power Savings



Power disable control register provides control bits that can enable or disable arrival of clock to several peripherals such as, PCM, CPCC, digital filters, front ends, DPWMs, UARTs, ADC-12 and more.

All these controls are enabled as default. If a specific peripheral is not used in a specific application the clock gate can be disabled in order to block the propagation of clock signal to that peripheral and therefore reduce the overall current consumption of the device.

3.8 Typical Temperature Characteristics

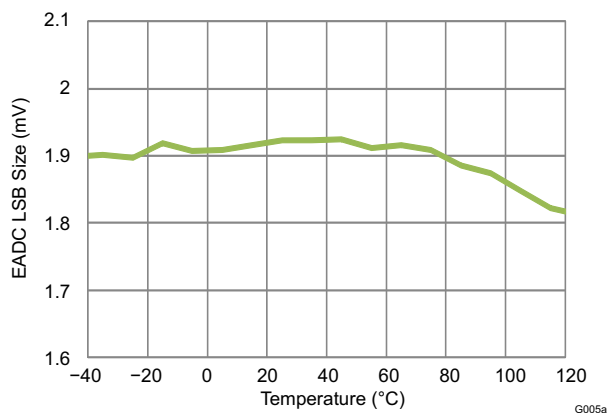

Figure 3-4. EADC LSB Size with 4X Gain (mV) vs. Temperature

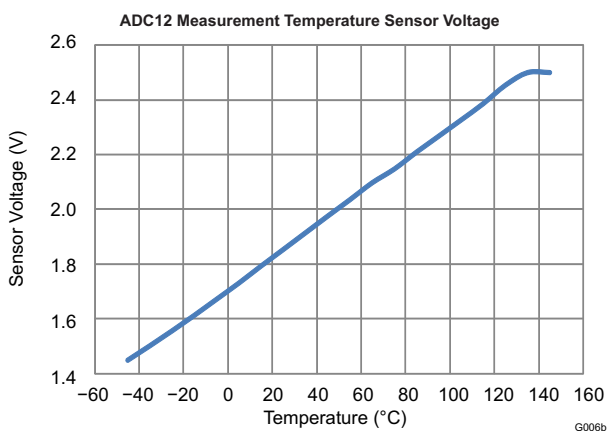

Figure 3-5. ADC12 Measurement Temperature Sensor Voltage vs. Temperature

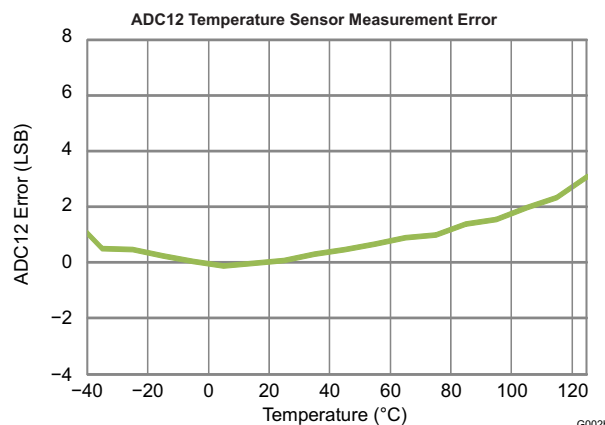

Figure 3-7. ADC12 Temperature Sensor Measurement Error vs. Temperature

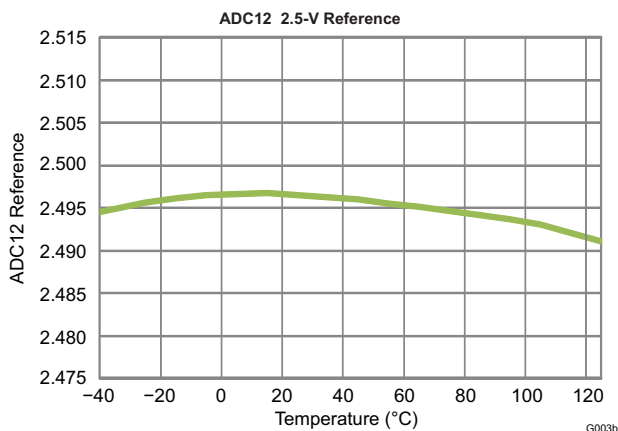

Figure 3-6. ADC12 2.5-V Reference vs. Temperature

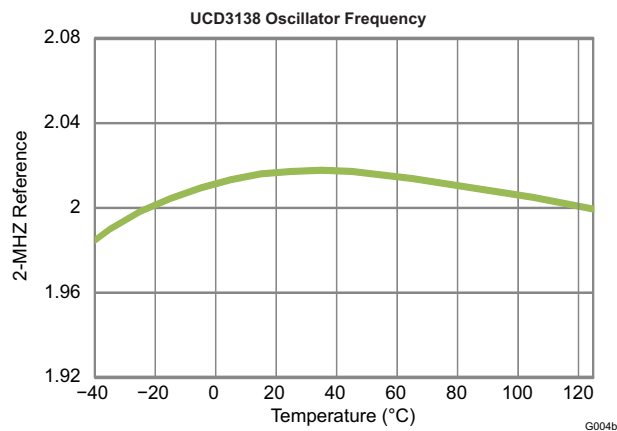

Figure 3-8. UCD3138 Oscillator Frequency (2MHz Reference, Divided Down from 250MHz) vs. Temperature

4 Functional Overview

4.1 ARM Processor

The ARM7TDMI-S processor is a synthesizable member of the ARM family of general purpose 32-bit microprocessors. The ARM architecture is based on RISC (Reduced Instruction Set Computer) principles where two instruction sets are available. The 32-bit ARM instruction set and the 16-bit Thumb instruction set. The Thumb instruction allows for higher code density equivalent to a 16-bit microprocessor, with the performance of the 32-bit microprocessor.

The three-staged pipelined ARM processor has fetch, decode and execute stage architecture. Major blocks in the ARM processor include a 32-bit ALU, 32 x 8 multiplier, and a barrel shifter. A JTAG port is also available for firmware debugging.

4.2 Memory

The UCD3138 (ARM7TDMI-S) is a Von-Neumann architecture, where a single bus provides access to all of the memory modules. All of the memory module addresses are sequentially aligned along the same address range. This applies to program flash, data flash, ROM and all other peripherals.

Within the UCD3138 architecture, there is a 1024x32-bit Boot ROM that contains the initial firmware startup routines for PMBUS communication and non-volatile (FLASH) memory download. This boot ROM is executed after power-up-reset checks if there is a valid FLASH program written. If a valid program is present, the ROM code branches to the main FLASH-program execution.

UCD3138 also supports customization of the boot program by allowing an alternative boot routine to be executed from program FLASH. This feature enables assignment of a unique address to each device; therefore, enabling firmware reprogramming even when several devices are connected on the same communication bus.

Two separate FLASH memory areas are present inside the device. The 32 kB Program FLASH is organized as an 8 k x 32 bit memory block and is intended to be for the firmware program. The block is configured with page erase capability for erasing blocks as small as 1kB per page, or with a mass erase for erasing the entire program FLASH array. The FLASH endurance is specified at 1000 erase/write cycles and the data retention is good for 100 years. The 2 kB data FLASH array is organized as a 512 x 32 bit memory (32 byte page size). The Data FLASH is intended for firmware data value storage and data logging. Thus, the Data FLASH is specified as a high endurance memory of 20 k cycles with embedded error correction code (ECC).

For run time data storage and scratchpad memory, a 4 kB RAM is available. The RAM is organized as a 1 k x 32 bit array.

4.2.1 CPU Memory Map and Interrupts

When the device comes out of power-on-reset, the data memories are mapped to the processor as follows:

4.2.1.1 Memory Map (After Reset Operation)

Address	Size	Module
0x0000_0000 – 0x0000_FFFF In 16 repeated blocks of 4K each	16 X 4K	Boot ROM
0x0001_0000 – 0x0001_7FFF	32K	Program Flash
0x0001_8800 – 0x0001_8FFF	2K	Data Flash
0x0001_9000 – 0x0001_9FFF	4K	Data RAM

4.2.1.2 Memory Map (Normal Operation)

Just before the boot ROM program gives control to FLASH program, the ROM configures the memory as follows:

Address	Size	Module
0x0000_0000 – 0x0000_7FFF	32K	Program Flash
0x0001_0000 – 0x0001_AFFF	4K	Boot ROM
0x0001_8800 – 0x0001_8FFF	2K	Data Flash
0x0001_9000 – 0x0001_9FFF	4K	Data RAM

4.2.1.3 Memory Map (System and Peripherals Blocks)

Address	Size	Module
0x0002_0000 - 0x0002_00FF	256	Loop Mux
0x0003_0000 - 0x0003_00FF	256	Fault Mux
0x0004_0000 - 0x0004_00FF	256	ADC
0x0005_0000 - 0x0005_00FF	256	DPWM 3
0x0006_0000 - 0x0006_00FF	256	Filter 2
0x0007_0000 - 0x0007_00FF	256	DPWM 2
0x0008_0000 - 0x0008_00FF	256	Front End/Ramp I/F 2
0x0009_0000 - 0x0009_00FF	256	Filter 1
0x000A_0000 - 0x000A_00FF	256	DPWM 1
0x000B_0000 – 0x000B_00FF	256	Front End/Ramp I/F 1
0x000C_0000 - 0x000C_00FF	256	Filter 0
0x000D_0000 - 0x000D_00FF	256	DPWM 0
0x000E_0000 - 0x000E_00FF	256	Front End/Ramp I/F 0
0xFFFF7_EC00 - 0xFFFF7_ECFF	256	UART 0
0xFFFF7_ED00 - 0xFFFF7_EDFF	256	UART 1
0xFFFF7_F000 - 0xFFFF7_F0FF	256	Miscellaneous Analog Control
0xFFFF7_F600 - 0xFFFF7_F6FF	256	PMBus Interface
0xFFFF7_FA00 - 0xFFFF7_FAFF	256	GIO
0xFFFF7_FD00 - 0xFFFF7_FDFF	256	Timer
0xFFFF_FD00 - 0xFFFF_FDFF	256	MMC
0xFFFF_FE00 - 0xFFFF_FEFF	256	DEC
0xFFFF_FF20 - 0xFFFF_FF37	23	CIM
0xFFFF_FF40 - 0xFFFF_FF50	16	PSA
0xFFFF_FFD0 - 0xFFFF_FFEC	28	SYS

The registers and bit definitions inside the System and Peripheral blocks are detailed in the programmer's guide for each peripheral.

4.2.2 Boot ROM

The UCD3138 incorporates a 4k boot ROM. This boot ROM includes support for:

- Program download through the PMBus
- Device initialization
- Examining and modifying registers and memory
- Verifying and executing program FLASH automatically
- Jumping to a customer defined boot program

The Boot ROM is entered automatically on device reset. It initializes the device and then performs checksums on the Program FLASH. If the first 2 kB of program FLASH has a valid checksum, the program jumps to location 0 in the Program FLASH. This permits the use of a customer boot program. If the first checksum fails, it performs a checksum on the complete 32 kB of program flash. If this is valid, it also jumps to location 0 in the program flash. This permits full automated program memory checking, when there is no need for a custom boot program.

If neither checksum is valid, the Boot ROM stays in control, and accepts commands via the PMBus interface

These functions can be used to read and write to all memory locations in the UCD3138. Typically they are used to download a program to Program Flash, and to command its execution

4.2.3 Customer Boot Program

As described above, it is possible to generate a user boot program using 2 kB or more of the Program Flash. This can support things which the Boot ROM does not support, including:

- Program download via UART – useful especially for applications where the UCD3138 is isolated from the host (e.g., PFC)
- Encrypted download – useful for code security in field updates.

4.2.4 Flash Management

The UCD3138 offers a variety of features providing for easy prototyping and easy flash programming. At the same time, high levels of security are possible for production code, even with field updates. Standard firmware will be provided for storing multiple copies of system parameters in data flash. This minimizes the risk of losing information if programming is interrupted.

4.3 System Module

The System Module contains the interface logic and configuration registers to control and configure all the memory, peripherals and interrupt mechanisms. The blocks inside the system module are the address decoder, memory management controller, system management unit, central interrupt unit, and clock control unit.

4.3.1 Address Decoder (DEC)

The Address Decoder generates the memory selects for the FLASH, ROM and RAM arrays. The memory map addresses are selectable through configurable register settings. These memory selects can be configured from 1 kB to 16 MB. Power on reset uses the default addresses in the memory map for ROM execution, which is then configured by the ROM code to the application setup. During access to the DEC registers, a wait state is asserted to the CPU. DEC registers are only writable in the ARM privilege mode for user mode protection.

4.3.2 Memory Management Controller (MMC)

The MMC manages the interface to the peripherals by controlling the interface bus for extending the read and write accesses to each peripheral. The unit generates eight peripheral select lines with 1 kB of address space decoding.

4.3.3 System Management (SYS)

The SYS unit contains the software access protection by configuring user privilege levels to memory or peripherals modules. It contains the ability to generate fault or reset conditions on decoding of illegal address or access conditions. A clock control setup for the processor clock (MCLK) speed, is also available.

4.3.4 Central Interrupt Module (CIM)

The CIM accepts 32 interrupt requests for meeting firmware timing requirements. The ARM processor supports two interrupt levels: FIQ and IRQ. FIQ is the highest priority interrupt. The CIM provides hardware expansion of interrupts by use of FIQ/IRQ vector registers for providing the offset index in a vector table. This numerical index value indicates the highest precedence channel with a pending interrupt and is used to locate the interrupt vector address from the interrupt vector table. Interrupt channel 0 has the lowest precedence and interrupt channel 31 has the highest precedence. To remove the interrupt request, the firmware should clear the request as the first action in the interrupt service routine. The request channels are maskable, allowing individual channels to be selectively disabled or enabled.

Table 4-1. Interrupt Priority Table

NAME	MODULE COMPONENT OR REGISTER	DESCRIPTION	PRIORITY
BRN_OUT_INT	Brownout	Brownout interrupt	0 (Lowest)
EXT_INT	External Interrupts	Interrupt on external input pin	1
WDRST_INT	Watchdog Control	Interrupt from watchdog exceeded (reset)	2
WDWAKE_INT	Watchdog Control	Wakeup interrupt when watchdog equals half of set watch time	3
SCI_ERR_INT	UART or SCI Control	UART or SCI error Interrupt. Frame, parity or overrun	4
SCI_RX_0_INT	UART or SCI Control	UART0 RX buffer has a byte	5
SCI_TX_0_INT	UART or SCI Control	UART0 TX buffer empty	6
SCI_RX_1_INT	UART or SCI Control	UART1 RX buffer has a byte	7
SCI_TX_1_INT	UART or SCI Control	UART1 TX buffer empty	8
PMBUS_INT		PMBus related interrupt	9
DIG_COMP_INT	12-bit ADC Control	Digital comparator interrupt	10
FE0_INT	Front End 0	"Prebias complete", "Ramp Delay Complete", "Ramp Complete", "Load Step Detected", "Over-Voltage Detected", "EADC saturated"	11
FE1_INT	Front End 1	"Prebias complete", "Ramp Delay Complete", "Ramp Complete", "Load Step Detected", "Over-Voltage Detected", "EADC saturated"	12
FE2_INT	Front End 2	"Prebias complete", "Ramp Delay Complete", "Ramp Complete", "Load Step Detected", "Over-Voltage Detected", "EADC saturated"	13
PWM3_INT	16-bit Timer PWM 3	16-bit Timer PWM3 counter overflow or compare interrupt	14
PWM2_INT	16-bit Timer PWM 2	16-bit Timer PWM2 counter Overflow or compare interrupt	15
PWM1_INT	16-bit Timer PWM 1	16-bit Timer PWM1 counter overflow or compare interrupt	16
PWM0_INT	16-bit timer PWM 0	16-bit Timer PWM1 counter overflow or compare interrupt	17
OVF24_INT	24-bit Timer Control	24-bit Timer counter overflow interrupt	18
CAPTURE_1_INT	24-bit Timer Control	24-bit Timer capture 1 interrupt	19
COMP_1_INT	24-bit Timer Control	24-bit Timer compare 1 interrupt	20
CAPTURE_0_INT	24-bit Timer Control	24-bit Timer capture 0 interrupt	21
COMP_0_INT	24-bit Timer Control	24-bit Timer compare 0 interrupt	22
CPCC_INT	Constant Power Constant Current	Mode switched in CPCC module Flag needs to be read for details	23
ADC_CONV_INT	12-bit ADC Control	ADC end of conversion interrupt	24
FAULT_INT	Fault Mux Interrupt	Analog comparator interrupts, Over-Voltage detection, Under-Voltage detection, LLM load step detection	25

Table 4-1. Interrupt Priority Table (continued)

NAME	MODULE COMPONENT OR REGISTER	DESCRIPTION	PRIORITY
DPWM3	DPWM3	Same as DPWM1	26
DPWM2	DPWM2	Same as DPWM1	27
DPWM1	DPWM1	1) Every (1-256) switching cycles 2) Fault Detection 3) Mode switching	28
DPWM0	DPWM0	Same as DPWM1	29
EXT_FAULT_INT	External Faults	Fault pin interrupt	30
SYS_SSL_INT	System Software	System software interrupt	31 (highest)

4.4 Peripherals

4.4.1 Digital Power Peripherals

At the core of the UCD3138 controller are 3 Digital Power Peripherals (DPP). Each DPP can be configured to drive from one to eight DPWM outputs. Each DPP consists of:

- Differential input error ADC (EADC) with sophisticated controls
- Hardware accelerated digital 2-pole/2-zero PID based compensator
- Digital PWM module with support for a variety of topologies

These can be connected in many different combinations, with multiple filters and DPWMs. They are capable of supporting functions like input voltage feed forward, current mode control, and constant current/constant power, etc.. The simplest configuration is shown in the following figure:



4.4.1.1 Front End

Figure 4-1 shows the block diagram of the front end module. It consists of a differential amplifier, an adjustable gain error amplifier, a high speed flash analog to digital converter (EADC), digital averaging filters and a precision high resolution set point DAC reference. The programmable gain amplifier in concert with the EADC and the adjustable digital gain on the EADC output work together to provide 9 bits of range with 6 bits of resolution on the EADC output. The output of the Front End module is a 9 bit sign extended result with a gain of 1 LSB / mV. Depending on the value of AFE selected, the resolution of this output could be either 1, 2, 4 or 8 LSBs. In addition Front End 0 has the ability to automatically select the AFE value such that the minimum resolution is maintained that still allows the voltage to fit within the range of the measurement. The EADC control logic receives the sample request from the DPWM module for initiating an EADC conversion. EADC control circuitry captures the EADC-9-bit-code and strobcs the digital compensator for processing of the representative error. The set point DAC has 10 bits with an additional 4 bits of dithering resulting in an effective resolution of 14 bits. This DAC can be driven from a variety of sources to facilitate things like soft start, nested loops, etc. Some additional features include the ability to change the polarity of the error measurement and an absolute value mode which automatically adds the DAC value to the error.

It is possible to operate the controller in a peak current mode control configuration. In this mode topologies like the phase shifted full bridge converter can be controlled to maintain transformer flux balance. The internal DAC can be ramped at a synchronously controlled slew rate to achieve a programmable slope compensation. This eliminates the sub-harmonic oscillation as well as improves input voltage feed-forward performance. A0 is a unity gain buffer used to isolate the peak current mode comparator. The offset of this buffer is specified in the [Electrical Characteristics](#) table.

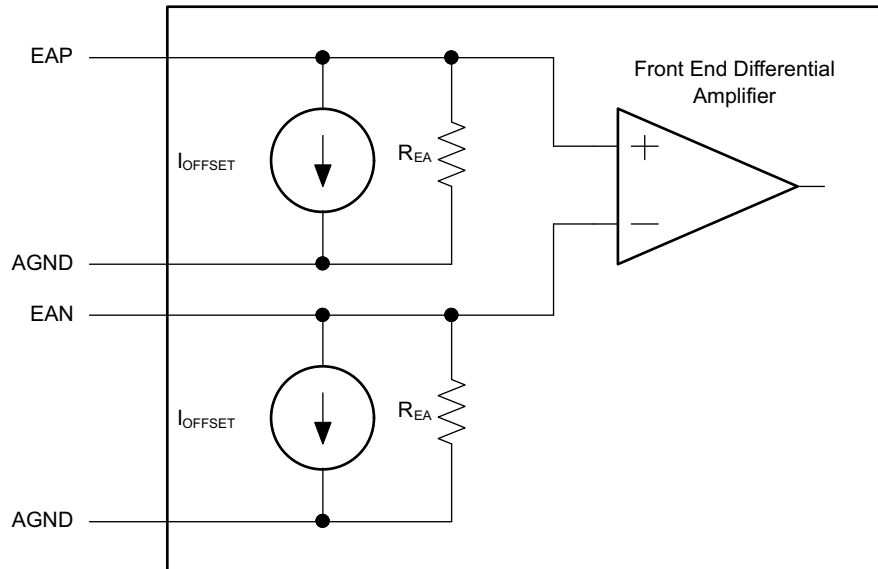

Figure 4-1. Input Stage of EADC Module

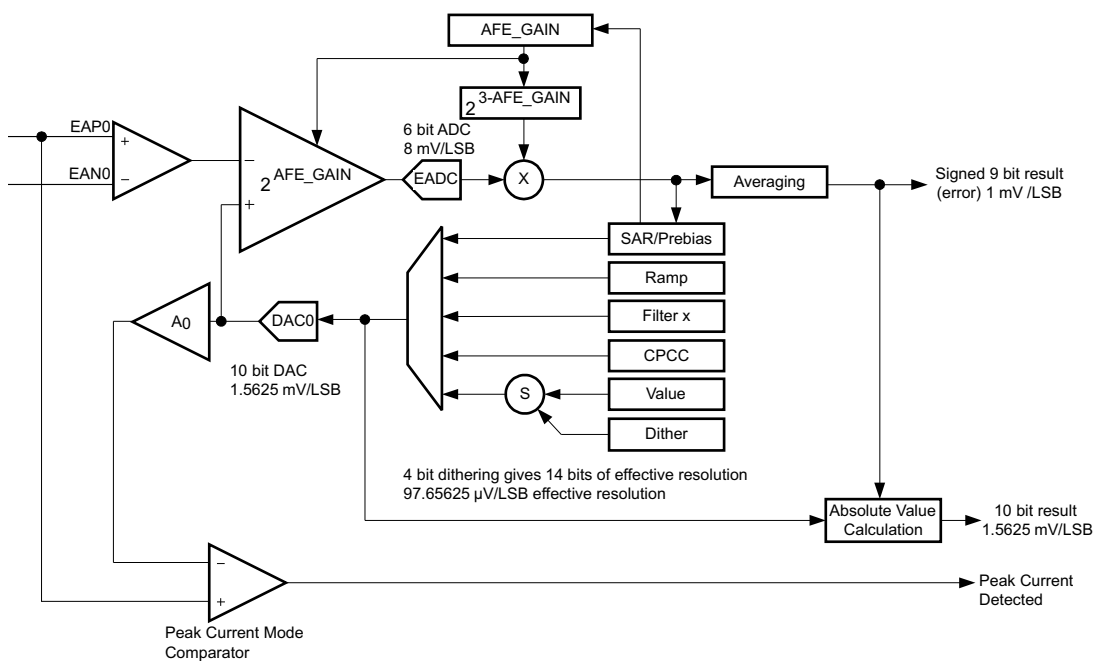

Figure 4-2. Front End Module

4.4.1.2 DPWM Module

The DPWM module represents one complete DPWM channel with 2 independent outputs, A and B. Multiple DPWM modules within the UCD3138 system can be configured to support all key power topologies. DPWM modules can be used as independent DPWM outputs, each controlling one power supply output voltage rail. It can also be used as a synchronized DPWM—with user selectable phase shift between the DPWM channels to control power supply outputs with multiphase or interleaved DPWM configurations.

The output of the filter feeds the high resolution DPWM module. The DPWM module produces the pulse width modulated outputs for the power stage switches. The compensator calculates the necessary duty ratio as a 24-bit number in Q23 fixed point format (23 bit integer with 1 sign bit). This represents a value within the range 0.0 to 1.0. This duty ratio value is used to generate the corresponding DPWM output ON time. The resolution of the DPWM ON time is 250 psec.

Each DPWM module can be synchronized to another module or to an external sync signal. An input SYNC signal causes a DPWM ramp timer to reset. The SYNC signal outputs—from each of the four DPWM modules—occur when the ramp timer crosses a programmed threshold. In this way the phase of the DPWM outputs for multiple power stages can be tightly controlled.

The DPWM logic is probably the most complex of the Digital Peripherals. It takes the output of the compensator and converts it into the correct DPWM output for several power supply topologies. It provides for programmable dead times and cycle adjustments for current balancing between phases. It controls the triggering of the EADC. It can synchronize to other DPWMs or to external sources. It can provide synchronization information to other DPWMs or to external recipients. In addition, it interfaces to several fault handling circuits. Some of the control for these fault handling circuits is in the DPWM registers. Fault handling is covered in the Fault Mux section.

Each DPWM module supports the following features:

- Dedicated 14 bit time-base with period and frequency control
- Shadow period register for end of period updates.
- Quad-event control registers (A and B, rising and falling) (Events 1-4)
 - Used for on/off DPWM duty ratio updates.
- Phase control relative to other DPWM modules
- Sample trigger placement for output voltage sensing at any point during the DPWM cycle.
- Support for 2 independent edge placement DPWM outputs (same frequency or period setting)
- Dead-time between DPWM A and B outputs
- High Resolution capabilities – 250 ps
- Pulse cycle adjustment of up to $\pm 8.192 \mu\text{s}$ ($32768 \times 250 \text{ ps}$)
- Active high/ active low output polarity selection
- Provides events to trigger both CPU interrupts and start of ADC12 conversions.

4.4.1.3 DPWM Events

Each DPWM can control the following timing events:

1. *Sample Trigger Count*—This register defines where the error voltage is sampled by the EADC in relationship to the DPWM period. The programmed value set in the register should be one fourth of the value calculated based on the DPWM clock. As the DCLK (DCLK = 62.5 MHz max) controlling the circuitry runs at one fourth of the DPWM clock (PCLK = 250MHz max). When this sample trigger count is equal to the DPWM Counter, it initiates a front end calculation by triggering the EADC, resulting in a CLA calculation, and a DPWM update. Over-sampling can be set for 2, 4 or 8 times the sampling rate.
2. *Phase Trigger Count*—count offset for slaving another DPWM (Multi-Phase/Interleaved operation).
3. *Period*—low resolution switching period count. (count of PCLK cycles)
4. *Event 1*—count offset for rising DPWM A event. (PCLK cycles)
5. *Event 2*—DPWM count for falling DPWM A event that sets the duty ratio. Last 4 bits of the register are for high resolution control. Upper 14 bits are the number of PCLK cycle counts.
6. *Event 3*—DPWM count for rising DPWM B event. Last 4 bits of the register are for high resolution control. Upper 14 bits are the number of PCLK cycle counts.
7. *Event 4*—DPWM count for falling DPWM B event. Last 4 bits of the register are for high resolution control. Upper 14 bits are the number of PCLK cycle counts.
8. *Cycle Adjust*—Constant offset for Event 2 and Event 4 adjustments.

Basic comparisons between the programmed registers and the DPWM counter can create the desired edge placements in the DPWM. High resolution edge capability is available on Events 2, 3 and 4.

Multi Mode Open Loop

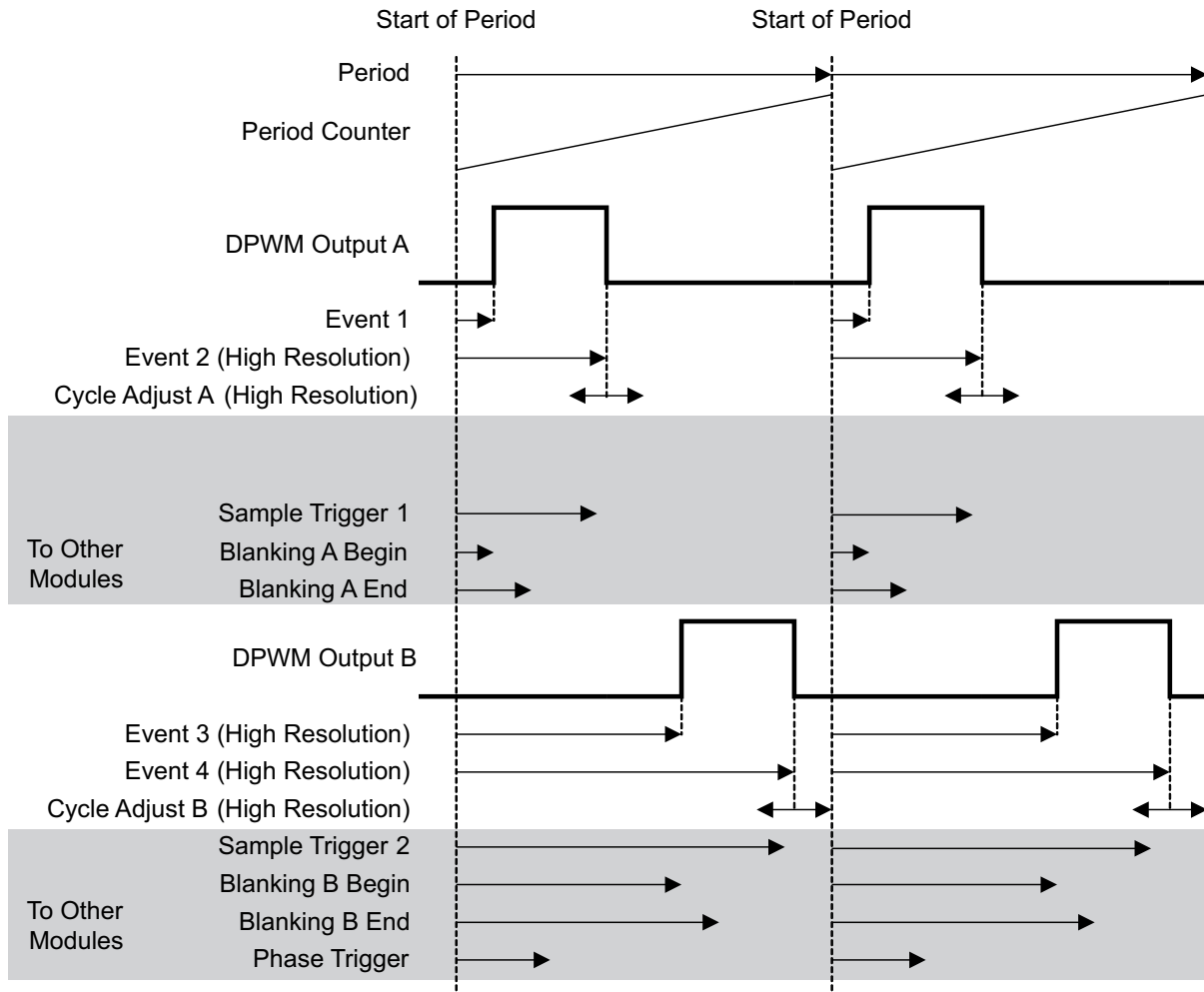

Events which change with DPWM mode:

DPWM A Rising Edge = Event 1
 DPWM A Falling Edge = Event 2 + Cycle Adjust A
 DPWM B Rising Edge = Event 3
 DPWM B Falling Edge = Event 4 + Cycle Adjust B
 Phase Trigger = Phase Trigger Register value

Events always set by their registers, regardless of mode:

Sample Trigger 1, Sample Trigger 2, Blanking A Begin, Blanking A End, Blanking B Begin, Blanking B End

The drawing above is for multi-mode, open loop. Open loop means that the DPWM is controlled entirely by its own registers, not by the filter output. In other words, the power supply control loop is not closed.

The Sample Trigger signals are used to trigger the Front End to sample input signals. The Blanking signals are used to blank fault measurements during noisy events, such as FET turn on and turn off. Additional DPWM modes are described below.

4.4.1.4 High Resolution DPWM

Unlike conventional PWM controllers where the frequency of the clock dictates the maximum resolution of PWM edges, the UCD3138 DPWM can generate waveforms with resolutions as small as 250 ps. This is 16 times the resolution of the clock driving the DPWM module.

This is achieved by providing the DPWM mechanism with 16 phase shifted clock signals of 250 MHz each. The high resolution section of DPWM can be enabled or disabled, also the resolution can be defined in several steps between 4ns to 250ps. This is done by setting the values of PWM_HR_MULTI_OUT_EN , HIRES_SCALE and ALL_PHASE_CLK_ENA inside the DPWM Control Register 1. See the Power Peripherals programmer's manual for details.

4.4.1.5 Over Sampling

The DPWM module has the capability to trigger an over sampling event by initiating the EADC to sample the error voltage. The default "00" configuration has the DPWM trigger the EADC once based on the sample trigger register value. The over sampling register has the ability to trigger the sampling 2, 4 or 8 times per PWM period. Thus the time the over sample happens is at the divide by 2, 4, or 8 time set in the sampling register. The "01" setting triggers 2X over sampling, the "10" setting triggers 4X over sampling, and the "11" triggers over sampling at 8X.

4.4.1.6 DPWM Interrupt Generation

The DPWM has the capability to generate a CPU interrupt based on the PWM frequency programmed in the period register. The interrupt can be scaled by a divider ratio of up to 255 for developing a slower interrupt service execution loop. This interrupt can be fed to the ADC circuitry for providing an ADC12 trigger for sequence synchronization. [Table 4-2](#) outlines the divide ratios that can be programmed.

4.4.1.7 DPWM Interrupt Scaling/Range

Table 4-2. DPWM Interrupt Divide Ratio

Interrupt Divide Setting	Interrupt Divide Count	Interrupt Divide Count (hex)	Switching Period Frames (assume 1MHz loop)	Number of 32 MHz Processor Cycles
1	0	00	1	32
2	1	01	2	64
3	3	03	4	128
4	7	07	8	256
5	15	0F	16	512
6	31	1F	32	1024
7	47	2F	48	1536
8	63	3F	64	2048
9	79	4F	80	2560
10	95	5F	96	3072
11	127	7F	128	4096
12	159	9F	160	5120
13	191	BF	192	6144
14	223	DF	224	7168
15	255	FF	256	8192

4.5 DPWM Modes of Operation

The DPWM is a complex logic system which is highly configurable to support several different power supply topologies. The discussion below will focus primarily on waveforms, timing and register settings, rather than on logic design.

The DPWM is centered on a period counter, which counts up from 0 to PRD, and then is reset and starts over again.

The DPWM logic causes transitions in many digital signals when the period counter hits the target value for that signal.

4.5.1 Normal Mode

In Normal mode, the Filter output determines the pulse width on DPWM A. DPWM B fits into the rest of the switching period, with a dead time separating it from the DPWM A on-time. It is useful for buck topologies, among others. Here is a drawing of the Normal Mode waveforms:

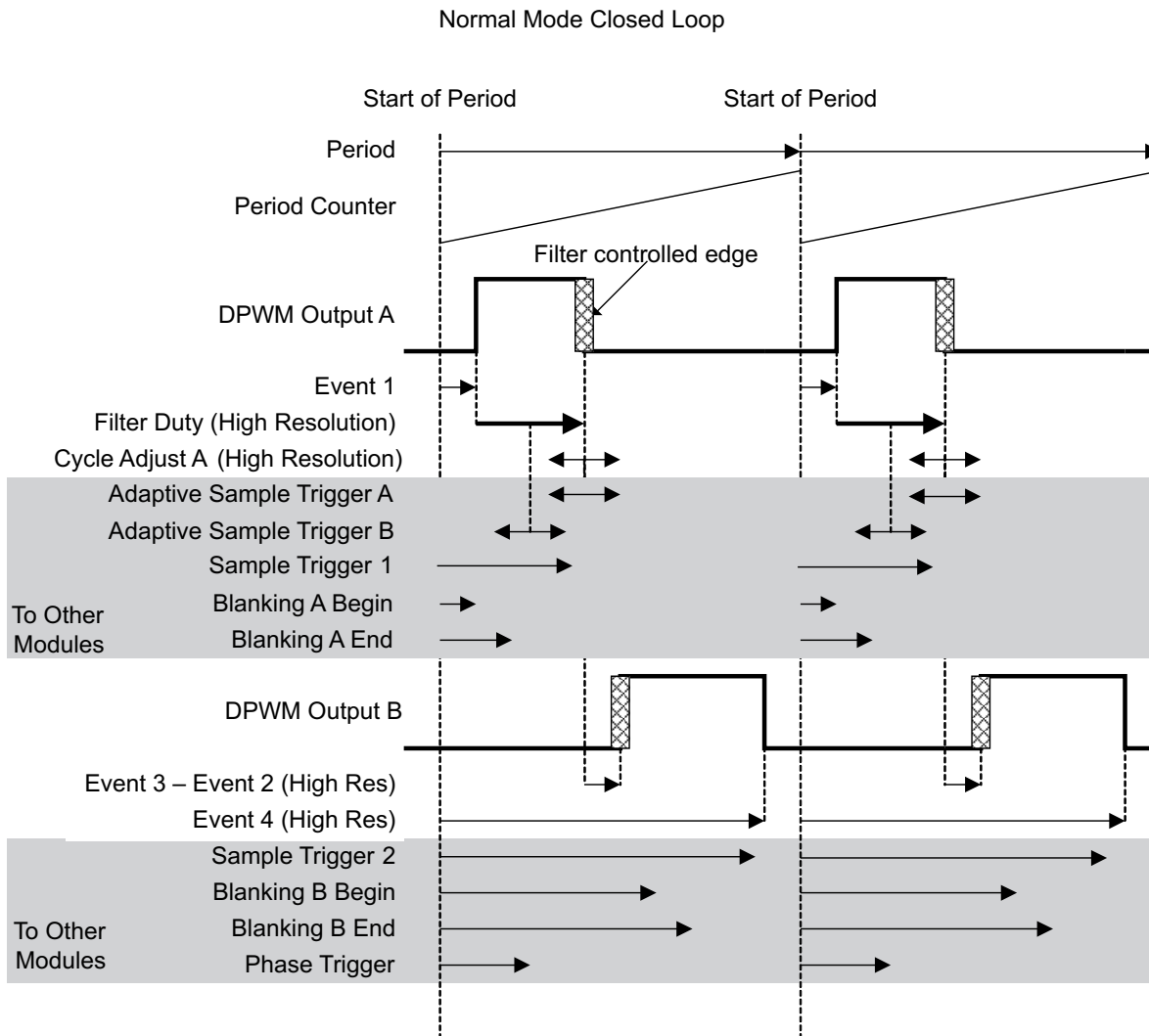

Events which change with DPWM mode:

- DPWM A Rising Edge = Event 1
- DPWM A Falling Edge = Event 1 + Filter Duty + Cycle Adjust A
- Adaptive Sample Trigger A = Event 1 + Filter Duty + Adaptive Sample Register or
- Adaptive Sample Trigger B = Event 1 + Filter Duty/2 + Adaptive Sample Register
- DPWM B Rising Edge = Event 1 + Filter Duty + Cycle Adjust A + (Event 3 – Event 2)
- DPWM B Falling Edge = Event 4
- Phase Trigger = Phase Trigger Register value or Filter Duty

Events always set by their registers, regardless of mode:

- Sample Trigger 1, Sample Trigger 2, Blanking A Begin, Blanking A End, Blanking B Begin, Blanking B End

Cycle adjust A can be used to adjust pulse widths on individual phases of a multi-phase system. This can be used for functions like current balancing. The Adaptive Sample Triggers can be used to sample in the middle of the on-time (for an average output), or at the end of the on-time (to minimize phase delay) The Adaptive Sample Register provides an offset from the center of the on-time. This can compensate for external delays, such as MOSFET and gate driver turn on times.

Blanking A-Begin and Blanking A-End can be used to blank out noise from the MOSFET turn on at the beginning of the period (DPWMA rising edge). Blanking B could be used at the turn off time of DPWMB. The other edges are dynamic, so blanking is more difficult.

Cycle Adjust B has no effect in Normal Mode.

4.6 Phase Shifting

In most modes, it is possible to synchronize multiple DPWM modules using the phase shift signal. The phase shift signal has two possible sources. It can come from the Phase Shift Register. This provides a fixed value, which is useful for an interleaved PFC, for example.

The phase shift value can also come from the filter output. In this case, the changes in the filter output causes changes in the phase relationship of two DPWM modules. This is useful for phase shifted full bridge topologies.

The following figure shows the mechanism of phase shift:

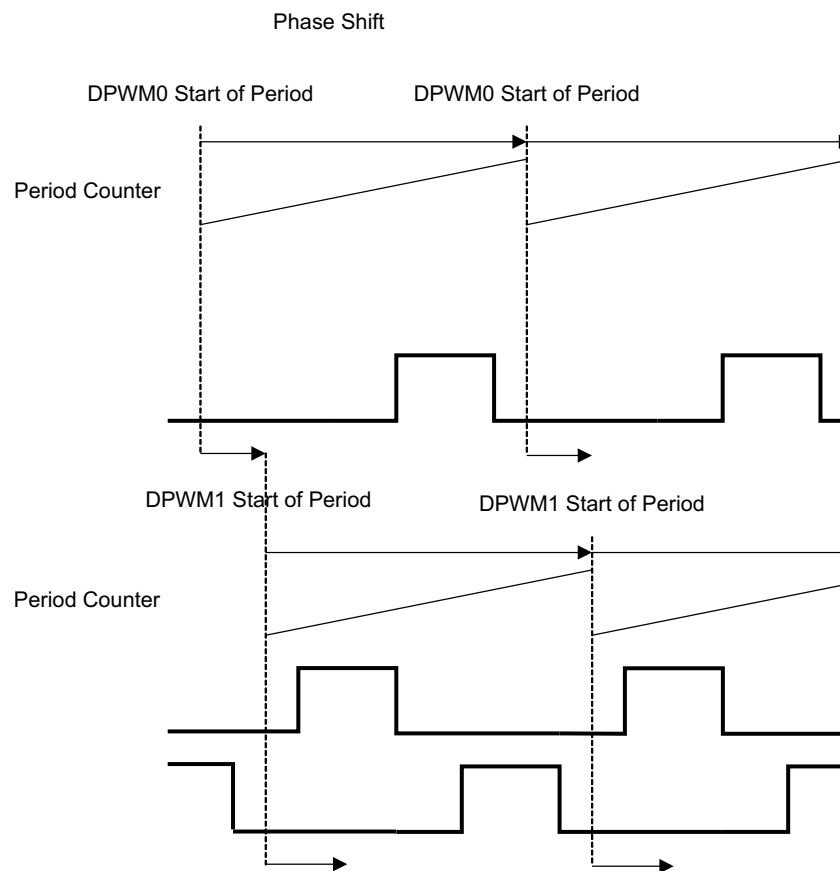

Phase Trigger = Phase Trigger Register value or Filter Duty

4.7 DPWM Multiple Output Mode

Multi mode is used for systems where each phase has only one driver signal. It enables each DPWM peripheral to drive two phases with the same pulse width, but with a time offset between the phases, and with different cycle adjusts for each phase.

Here is a diagram for Multi-Mode:

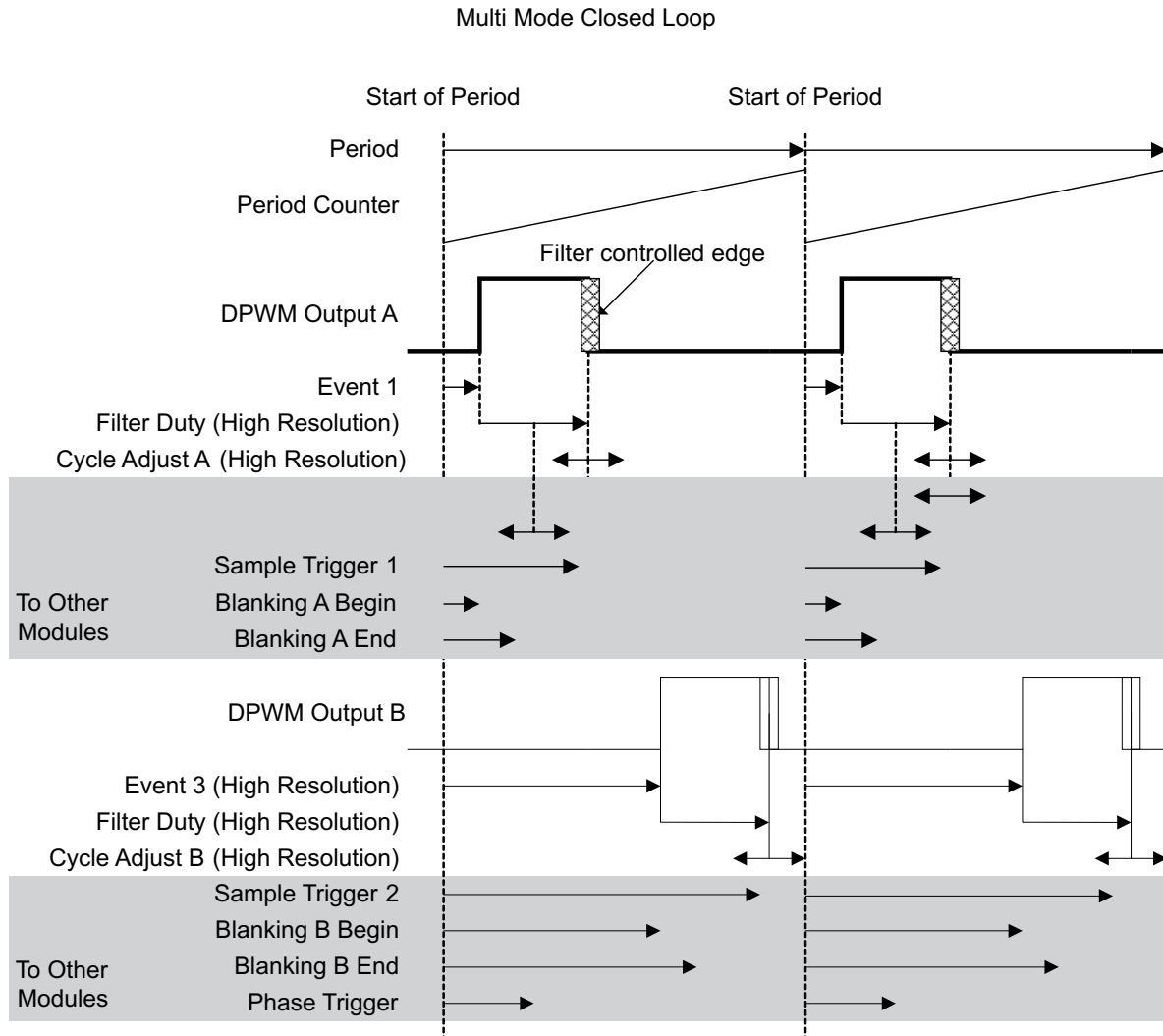

Events which change with DPWM mode:

DPWM A Rising Edge = Event 1
 DPWM A Falling Edge = Event 1 + Filter Duty + Cycle Adjust A
 Adaptive Sample Trigger A = Event 1 + Filter Duty + Adaptive Sample Register or
 Adaptive Sample Trigger B = Event 1 + Filter Duty/2 + Adaptive Sample Register
 DPWM B Rising Edge = Event 3
 DPWM B Falling Edge = Event 3 + Filter Duty + Cycle Adjust B
 Phase Trigger = Phase Trigger Register value or Filter Duty

Events always set by their registers, regardless of mode:

Sample Trigger 1, Sample Trigger 2, Blanking A Begin, Blanking A End, Blanking B Begin, Blanking B End

Event 2 and Event 4 are not relevant in Multi mode.

DPWMB can cross over the period boundary safely, and still have the proper pulse width, so full 100% pulse width operation is possible. DPWMA cannot cross over the period boundary.

Since the rising edge on DPWM B is also fixed, Blanking B-Begin and Blanking B-End can be used for blanking this rising edge.

And, of course, Cycle Adjust B is usable on DPWM B.

4.8 DPWM Resonant Mode

This mode provides a symmetrical waveform where DPWMA and DPWMB have the same pulse width. As the switching frequency changes, the dead times between the pulses remain the same.

The equations for this mode are designed for a smooth transition from PWM mode to resonant mode, as described in the [LLC Example](#) section. Here is a diagram of this mode:

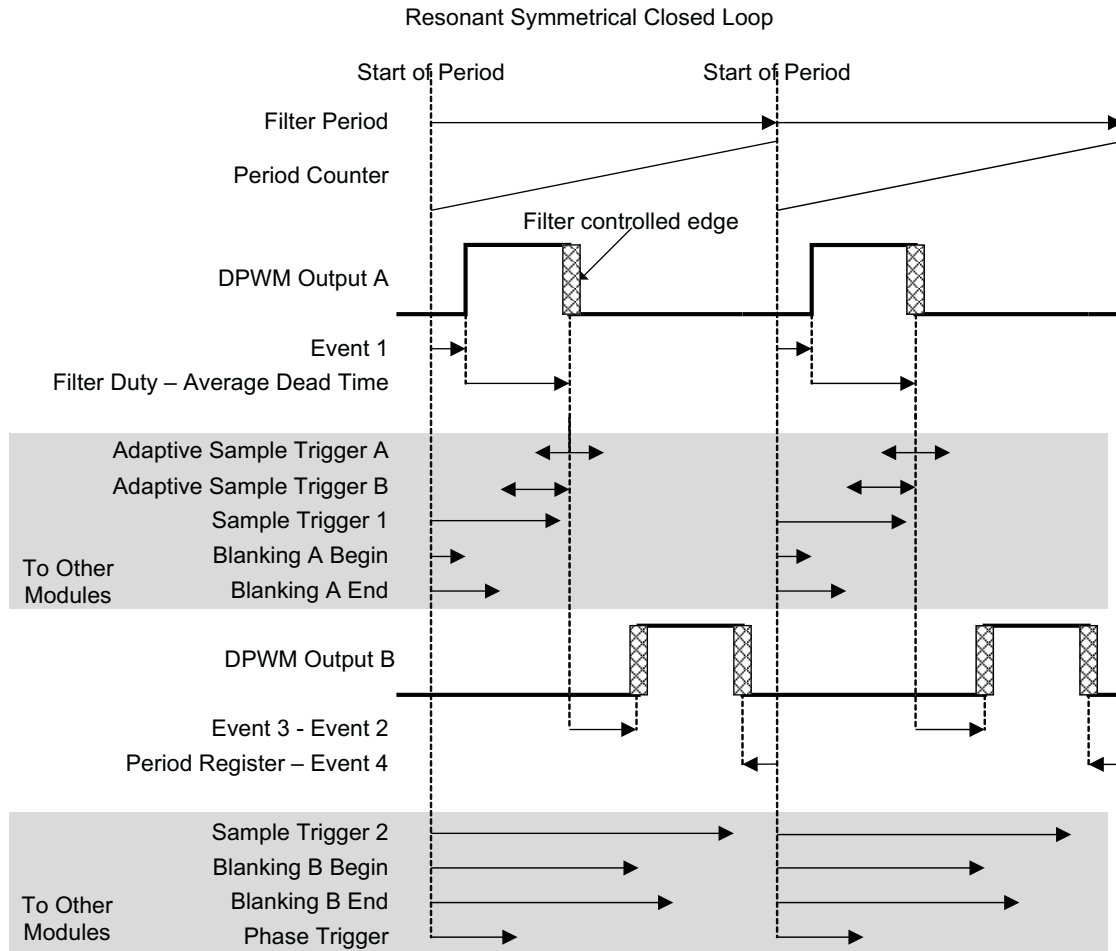

Events which change with DPWM mode:

$$\begin{aligned} \text{Dead Time 1} &= \text{Event 3} - \text{Event 2} \\ \text{Dead Time 2} &= \text{Event 1} + \text{Period Register} - \text{Event 4} \\ \text{Average Dead Time} &= (\text{Dead Time 1} + \text{Dead Time 2})/2 \end{aligned}$$

$$\begin{aligned} \text{DPWM A Rising Edge} &= \text{Event 1} \\ \text{DPWM A Falling Edge} &= \text{Event 1} + \text{Filter Duty} - \text{Average Dead Time} \\ \text{Adaptive Sample Trigger A} &= \text{Event 1} + \text{Filter Duty} + \text{Adaptive Sample Register} \\ \text{Adaptive Sample Trigger B} &= \text{Event 1} + \text{Filter Duty}/2 + \text{Adaptive Sample Register} \\ \text{DPWM B Rising Edge} &= \text{Event 1} + \text{Filter Duty} - \text{Average Dead Time} + (\text{Event 3} - \text{Event 2}) \\ \text{DPWM B Falling Edge} &= \text{Filter Period} - (\text{Period Register} - \text{Event 4}) \\ \text{Phase Trigger} &= \text{Phase Trigger Register value or Filter Duty} \end{aligned}$$

Events always set by their registers, regardless of mode:

Sample Trigger 1, Sample Trigger 2, Blanking A Begin, Blanking A End, Blanking B Begin, Blanking B End

The Filter has two outputs, Filter Duty and Filter Period. In this case, the Filter is configured so that the Filter Period is twice the Filter Duty. So if there were no dead times, each DPWM pin would be on for half of the period. For dead time handling, the average of the two dead times is subtracted from the Filter Duty for both DPWM pins. Therefore, both pins will have the same on-time, and the dead times will be fixed regardless of the period. The only edge which is fixed relative to the start of the period is the rising edge of DPWM A. This is the only edge for which the blanking signals can be used easily.

4.9 Triangular Mode

Triangular mode provides a stable phase shift in interleaved PFC and similar topologies. In this case, the PWM pulse is centered in the middle of the period, rather than starting at one end or the other. In Triangular Mode, only DPWM-B is available. Here is a diagram for Triangular Mode:

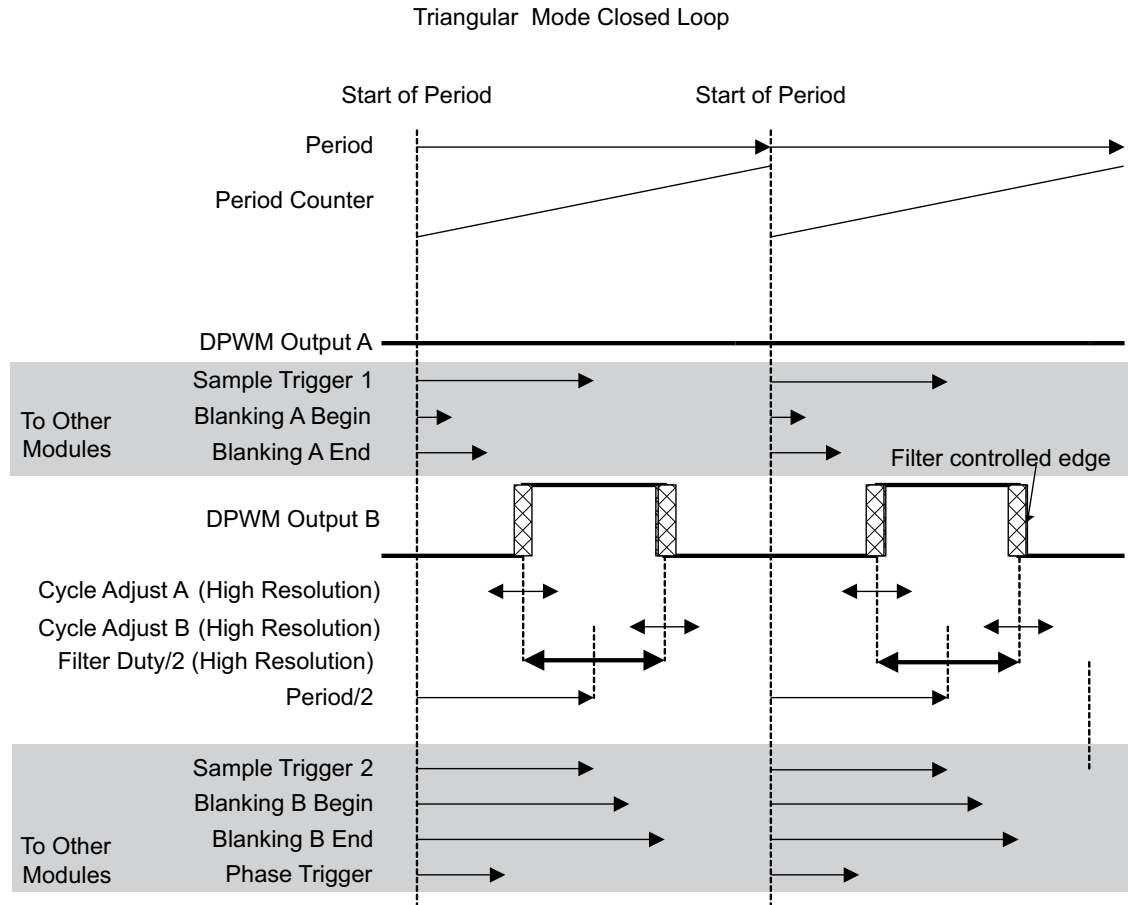

Events which change with DPWM mode:

DPWM A Rising Edge = None
 DPWM A Falling Edge = None
 Adaptive Sample Trigger = None
 DPWM B Rising Edge = $\text{Period}/2 - \text{Filter Duty}/2 + \text{Cycle Adjust A}$
 DPWM B Falling Edge = $\text{Period}/2 + \text{Filter Duty}/2 + \text{Cycle Adjust B}$
 Phase Trigger = Phase Trigger Register value or Filter Duty

Events always set by their registers, regardless of mode:

Sample Trigger 1, Sample Trigger 2, Blanking A Begin, Blanking A End, Blanking B Begin, Blanking B End

All edges are dynamic in triangular mode, so fixed blanking is not that useful. The adaptive sample trigger is not needed. It is very easy to put a fixed sample trigger exactly in the center of the FET on-time, because the center of the on-time does not move in this mode.

4.10 Leading Edge Mode

Leading edge mode is very similar to Normal mode, reversed in time. The DPWM A falling edge is fixed, and the rising edge moves to the left, or backwards in time, as the filter output increases. The DPWM B falling edge stays ahead of the DPWMA rising edge by a fixed dead time. Here is a diagram of the Leading Edge Mode:

Leading Edge Closed Loop

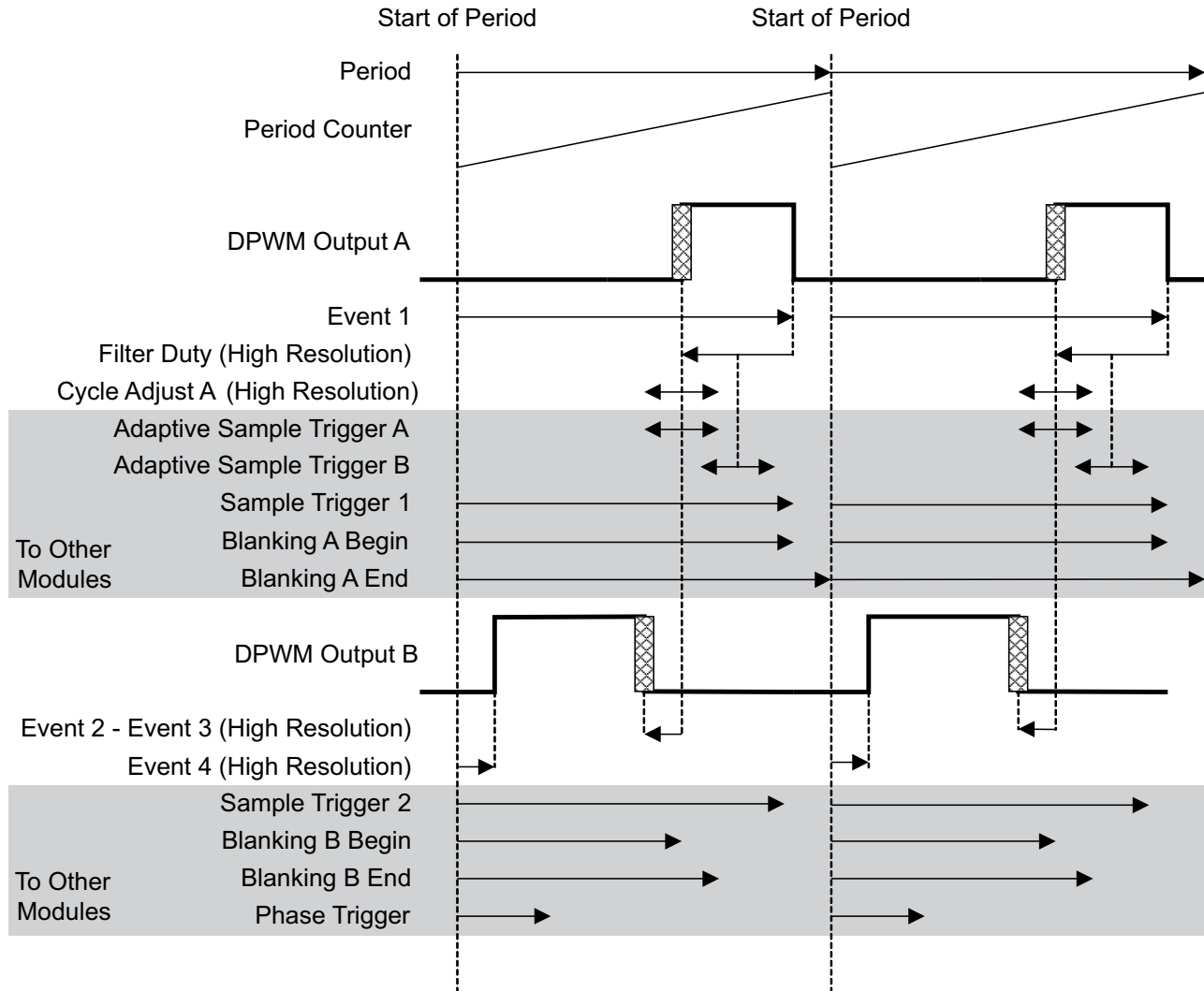

Events which change with DPWM mode:

DPWM A Falling Edge = Event 1
 DPWM A Rising Edge = Event 1 - Filter Duty + Cycle Adjust A
 Adaptive Sample Trigger A = Event 1 - Filter Duty + Adaptive Sample Register or
 Adaptive Sample Trigger B = Event 1 - Filter Duty/2 + Adaptive Sample Register
 DPWM B Rising Edge = Event 4
 DPWM B Falling Edge = Event 1 - Filter Duty + Cycle Adjust A -(Event 2 – Event 3)
 Phase Trigger = Phase Trigger Register value or Filter Duty

Events always set by their registers, regardless of mode:

Sample Trigger 1, Sample Trigger 2, Blanking A Begin, Blanking A End, Blanking B Begin, Blanking B End

As in the Normal mode, the two edges in the middle of the period are dynamic, so the fixed blanking intervals are mainly useful for the edges at the beginning and end of the period.

4.11 Sync FET Ramp and IDE Calculation

The UCD3138 has built in logic for controlling MOSFETs for synchronous rectification (Sync FETs). This comes in two forms:

- Sync FET ramp
- Ideal Diode Emulation (IDE) calculation

When starting up a power supply, sometimes there is already a voltage on the output – this is called prebias. It is very difficult to calculate the ideal Sync FET on-time for this case. If it is not calculated correctly, it may pull down the pre-bias voltage, causing the power supply to sink current.

To avoid this, Sync FETs are not turned on until after the power supply has ramped up to the nominal voltage. The Sync FETs are turned on gradually in order to avoid an output voltage glitch. The Sync FET Ramp logic can be used to turn them on at a rate below the bandwidth of the filter.

In discontinuous mode, the ideal on-time for the Sync FETs is a function of V_{in} , V_{out} , and the primary side duty cycle (D). The IDE logic in the UCD3138 takes V_{in} and V_{out} data from the firmware and combines it with D data from the filter hardware. It uses this information to calculate the ideal on-time for the Sync FETs.

4.12 Automatic Mode Switching

Automatic Mode switching enables the DPWM module to switch between modes automatically, with no firmware intervention. This is useful to increase efficiency and power range. The following paragraphs describe phase-shifted full bridge and LLC examples:

4.12.1 Phase Shifted Full Bridge Example

In phase shifted full bridge topologies, efficiency can be increased by using pulse width modulation, rather than phase shift, at light load. This is shown below:

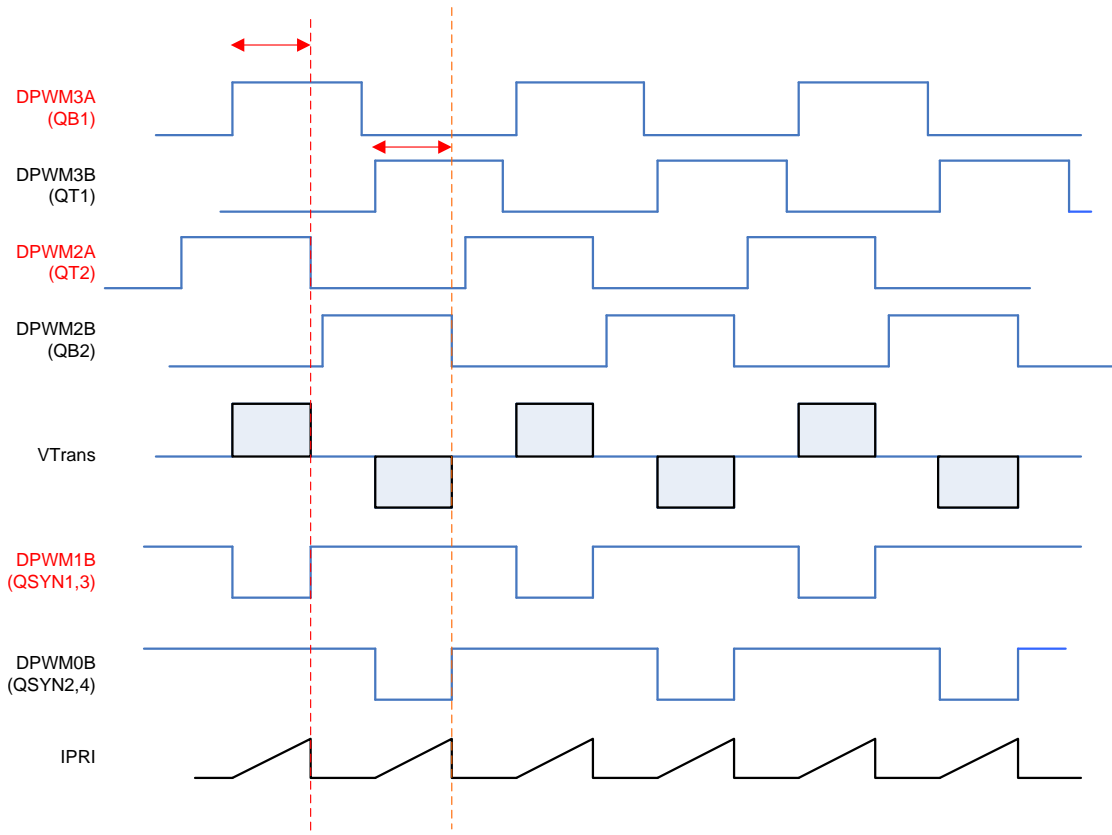

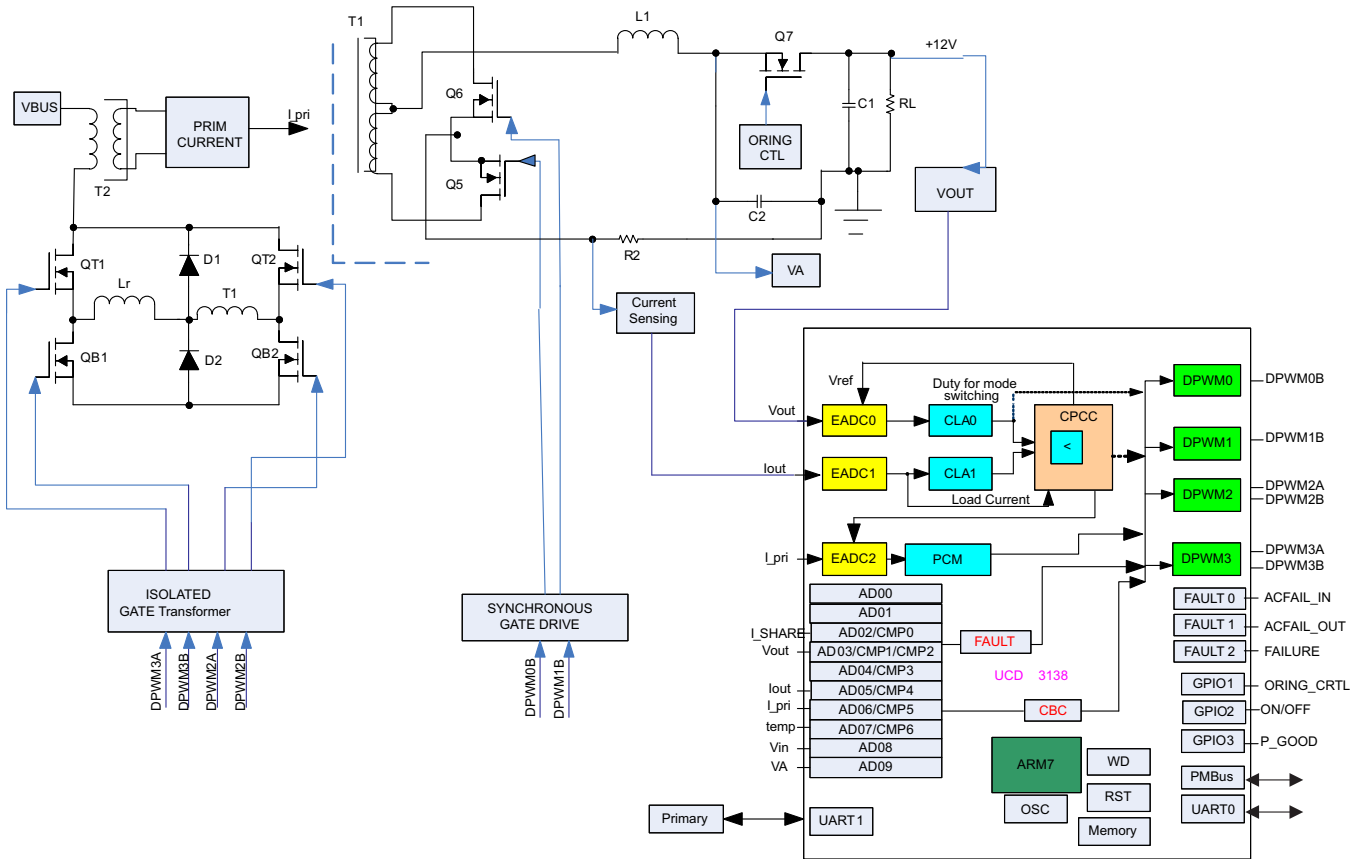
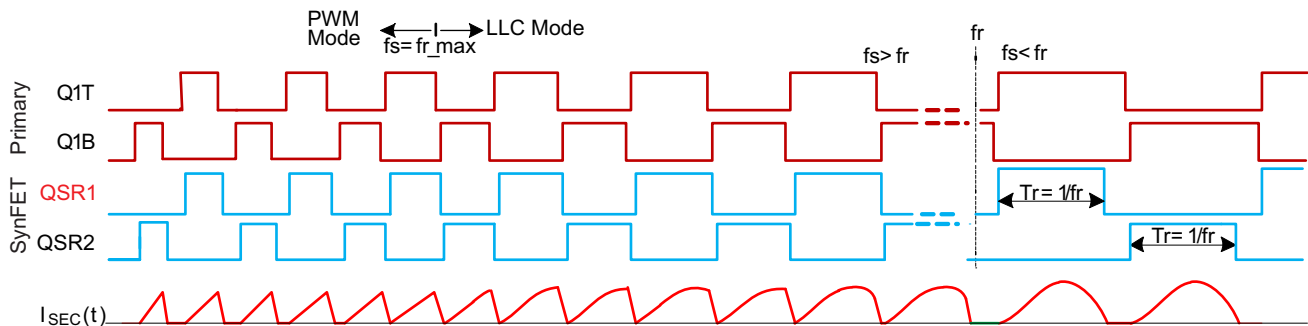

Figure 4-3. Secondary-Referenced Phase-Shifted Full Bridge Control With Synchronous Rectification

4.12.2 LLC Example

In LLC, three modes are used. At the highest frequency, a pulse width modulated mode (Multi Mode) is used. As the frequency decreases, resonant mode is used. As the frequency gets still lower, the synchronous MOSFET drive changes so that the on-time is fixed and does not increase. In addition, the LLC control supports cycle-by-cycle current limiting. This protection function operates by a comparator monitoring the maximum current during the DPWMA conduction time. Any time this current exceeds the programmable comparator reference the pulse is immediately terminated. Due to classic instability issues associated with half-bridge topologies it is also possible to force DPWMB to match the truncated pulse width of DPWMA. Here are the waveforms for the LLC:



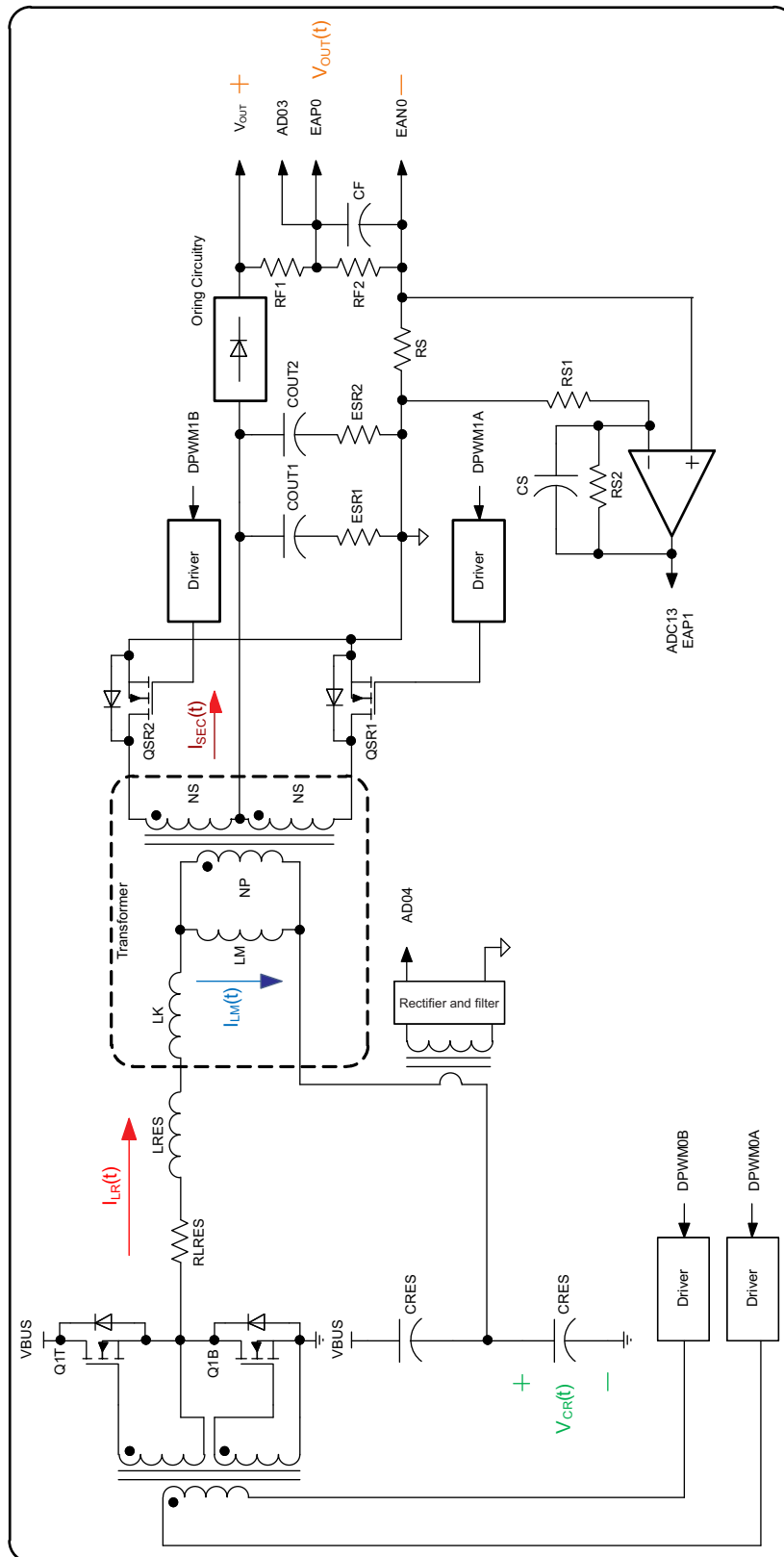
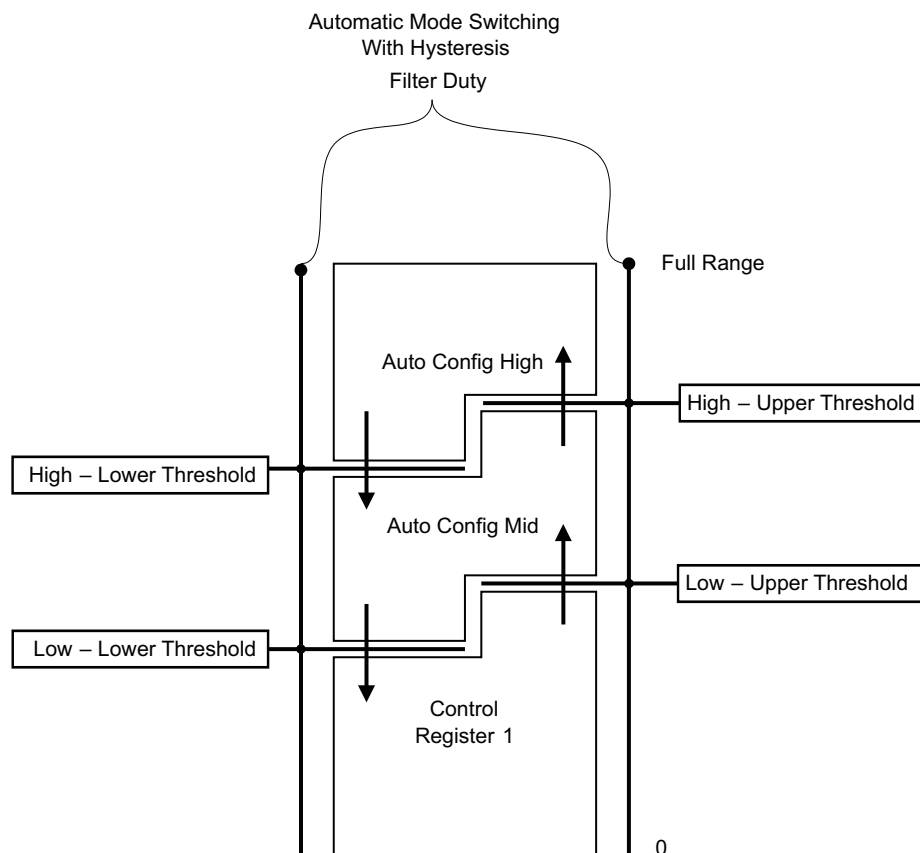

Figure 4-4. Secondary-Referenced Half-Bridge Resonant LLC Control With Synchronous Rectification

4.12.3 Mechanism for Automatic Mode Switching

The UCD3138 allows the customer to enable up to two distinct levels of automatic mode switching. These different modes are used to enhance light load operation, short circuit operation and soft start. Many of the configuration parameters for the DPWM are in DPWM Control Register 1. For automatic mode switching, some of these parameters are duplicated in the Auto Config Mid and Auto Config High registers.

If automatic mode switching is enabled, the filter duty signal is used to select which of these three registers is used. There are 4 registers which are used to select the points at which the mode switching takes place. They are used as shown below.



As shown, the registers are used in pairs for hysteresis. The transition from Control Register 1 to Auto Config Mid only takes place when the Filter Duty goes above the Low Upper threshold. It does not go back to Auto Config Mid until the Low Lower Threshold is passed. This prevents oscillation between modes if the filter duty is close to a mode switching point.

4.13 DPWMC, Edge Generation, IntraMux

The UCD3138 has hardware for generating complex waveforms beyond the simple DPWMA and DPWMB waveforms already discussed – DPWMC, the Edge Generation Module, and the IntraMux.

DPWMC is a signal inside the DPWM logic. It goes high at the Blanking A begin time, and low at the Blanking A end time.

The Edge Gen module takes DPWMA and DPWMB from its own DPWM module, and the next one, and uses them to generate edges for two outputs. For DPWM3, the DPWM0 is considered to be the next DPWM. Each edge (rising and falling for DPWMA and DPWMB) has 8 options which can cause it.

The options are:

- 0 = DPWM(n) A Rising edge
- 1 = DPWM(n) A Falling edge
- 2 = DPWM(n) B Rising edge
- 3 = DPWM(n) B Falling edge
- 4 = DPWM(n+1) A Rising edge
- 5 = DPWM(n+1) A Falling edge
- 6 = DPWM(n+1) B Rising edge
- 7 = DPWM(n+1) B Falling edge

Where “n” is the numerical index of the DPWM module of interest. For example n=1 refers to DPWM1.

The Edge Gen is controlled by the DPWMEDGEGEN register. It also has an enable/disable bit.

The IntraMux is controlled by the Auto Config registers. Intra Mux is short for intra multiplexer. The IntraMux takes signals from multiple DPWMs and from the Edge Gen and combines them logically to generate DPWMA and DPWMB signals. This is useful for topologies like phase-shifted full bridge, especially when they are controlled with automatic mode switching. Of course, it can all be disabled, and DPWMA and DPWMB will be driven as described in the sections above. If the Intra Mux is enabled, high resolution must be disabled, and DPWM edge resolution goes down to 4 ns.

Here is a drawing of the Edge Gen/Intra Mux:

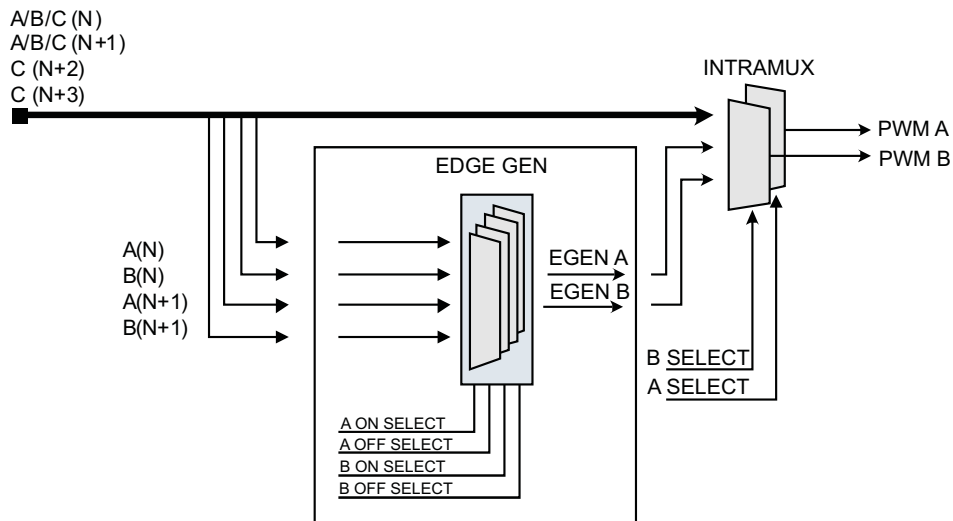

Here is a list of the IntraMux modes for DPWMA:

- 0 = DPWMA(n) pass through (default)
- 1 = Edge-gen output, DPWMA(n)
- 2 = DPWNC(n)
- 3 = DPWMB(n) (Crossover)
- 4 = DPWMA(n+1)

5 = DPWMB(n+1)

6 = DPWMC(n+1)

7 = DPWMC(n+2)

8 = DPWMC(n+3)

and for DPWMB:

0 = DPWMB(n) pass through (default)

1 = Edge-gen output, DPWMB(n)

2 = DPWNC(n)

3 = DPWMA(n) (Crossover)

4 = DPWMA(n+1)

5 = DPWMB(n+1)

6 = DPWMC(n+1)

7 = DPWMC(n+2)

8 = DPWMC(n+3)

The DPWM number wraps around just like the Edge Gen unit. For DPWM3 the following definitions apply:

DPWM(n)	DPWM3
DPWM(n+1)	DPWM0
DPWM(n+2)	DPWM1
DPWM(n+3)	DPWM2

4.14 Filter

The UCD3138 filter is a PID filter with many enhancements for power supply control. Some of its features include:

- Traditional PID Architecture
- Programmable non-linear limits for automated modification of filter coefficients based on received EADC error
- Multiple coefficient sets fully configurable by firmware
- Full 24-bit precision throughout filter calculations
- Programmable clamps on integrator branch and filter output
- Ability to load values into internal filter registers while system is running
- Ability to stall calculations on any of the individual filter branches
- Ability to turn off calculations on any of the individual filter branches
- Duty cycle, resonant period, or phase shift generation based on filter output.
- Flux balancing
- Voltage feed forward

Here is the first section of the Filter :

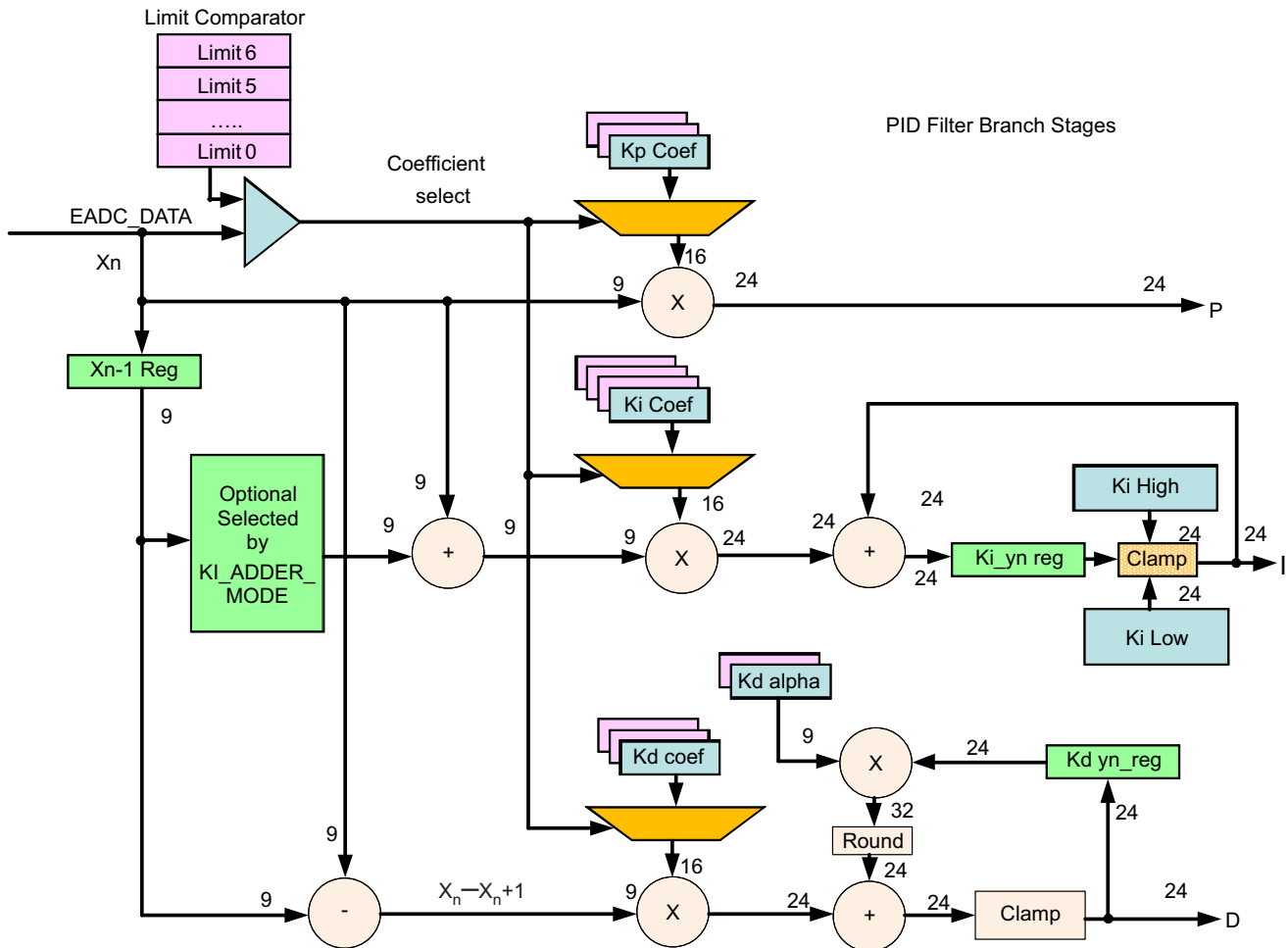

The filter input, X_n , generally comes from a front end. Then there are three branches, P, I, and D. Note that the D branch also has a pole, Kd Alpha. Clamps are provided both on the I branch and on the D alpha pole.

The filter also supports a nonlinear mode, where up to 7 different sets of coefficients can be selected depending on the magnitude of the error input X_n . This can be used to increase the filter gain for higher errors to improve transient response.

Here is the output section of the filter (S0.23 means that there is 1 sign bit, 0 integer bits and 23 fractional bits):

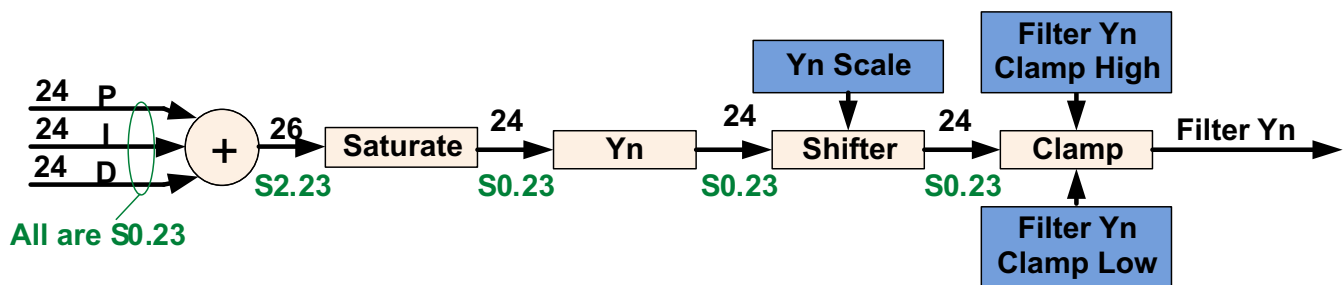

This section combines the P, I, and D sections, and provides for saturation, scaling, and clamping.

There is a final section for the filter, which permits its output to be matched to the DPWM:

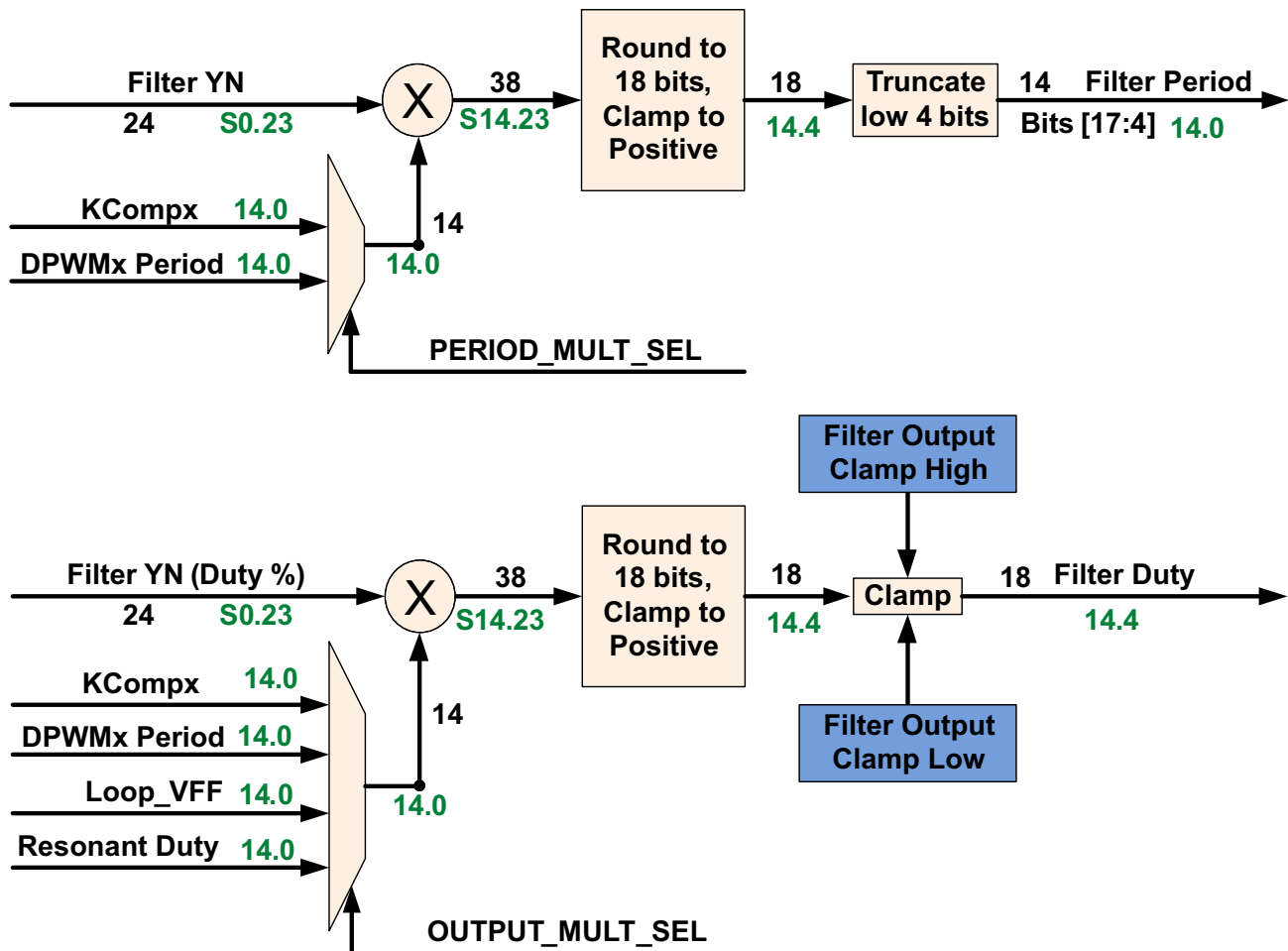

This permits the filter output to be multiplied by a variety of correction factors to match the DPWM Period, to provide for Voltage Feed Forward, or for other purposes. After this, there is another clamp. For resonant mode, the filter can be used to generate both period and duty cycle.

4.14.1 Loop Multiplexer

The Loop Mux controls interconnections between the filters, front ends, and DPWMs. Any filter, front end, and DPWM can be combined with each other in many configurations.

It also controls the following connections:

- DPWM to Front End
- Front End DAC control from Filters or Constant Current/Constant Power Module
- Filter Special Coefficients and Feed Forward
- DPWM synchronization
- Filter to DPWM

The following control modules are configured in the Loop Mux:

- Constant Power/Constant Current
- Cycle Adjustment (Current and flux balancing)
- Global Period
- Light Load (Burst Mode)
- Analog Peak Current Mode

4.14.2 Fault Multiplexer

In order to allow a flexible way of mapping several fault triggering sources to all the DPWMs channels, the UCD3138 provides an extensive array of multiplexers that are united under the name Fault Mux module.

The Fault Mux Module supports the following types of mapping between all the sources of fault and all different fault response mechanism inside each DPWM module.

- Many fault sources mapped to a single fault response mechanism. For instance an analog comparator in charge of over voltage protection, a digital comparator in charge of over current protection and an external digital fault pin can be all mapped to a fault-A signal connected to a single FAULT MODULE and shut down DPWM1-A.
- A single fault source can be mapped to many fault response mechanisms inside many DPWM modules. For instance an analog comparator in charge of over current protection can be mapped to DPWM-0 through DPWM-3 by way of several fault modules.
- Many fault sources can be mapped to many fault modules inside many DPWM modules.

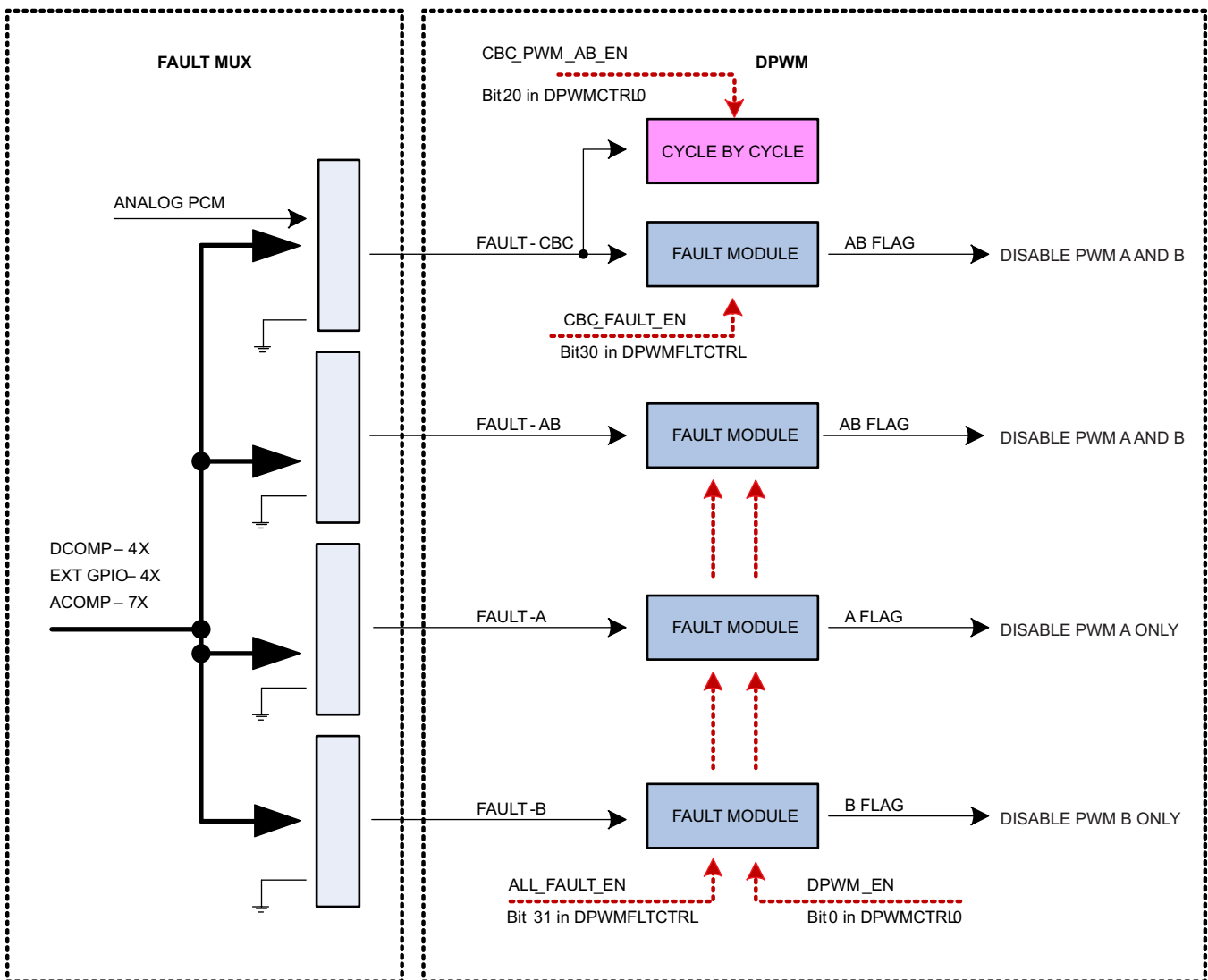

The Fault Mux Module provides a multitude of fault protection functions within the UCD3138 high-speed loop (Front End Control, Filter, DPWM and Loop Mux modules). The Fault Mux Module allows highly configurable fault generation based on digital comparators, high-speed analog comparators and external fault pins. Each of the fault inputs to the DPWM modules can be configured to one or any combination of the fault events provided in the Fault Mux Module.

Each one of the DPWM engines has four fault modules. The modules are called CBC fault module, AB fault module, A fault module and B fault module.

The internal circuitry in all the four fault modules is identical, and the difference between the modules is limited to the way the modules are attached to the DPWMs.

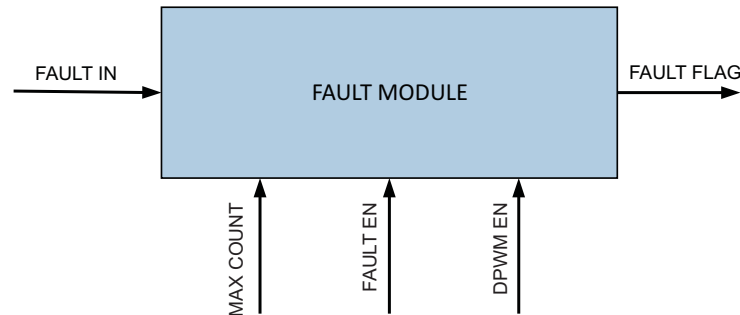

All fault modules provide immediate fault detection but only once per DPWM switching cycle. Each one of the fault modules own a separate max_count and the fault flag will be set only if sequential cycle-by-cycle faults count exceeds max_count.

Once the fault flag is set DPWMs need to be disabled by DPWM_EN going low in order to clear the fault flags. Please note, all four Fault Modules share the same DPWM_EN control, all fault flags (output of Fault Modules) will be cleared simultaneously.

All four Fault Modules share the same global FAULT_EN as well. Therefore a specific Fault Module cannot be enabled/ disabled separately.



Unlike Fault Modules, only one Cycle by Cycle block is available in each DPWM module.

The Cycle by Cycle block works in conjunction with CBC Fault Module and enables DPWM reaction to signals arriving from Analog Peak current mode (PCM) module.

The Fault Mux Module supports the following basic functions:

- 4 digital comparators with programmable thresholds and fault generation
- Configuration for 7 high speed analog comparators with programmable thresholds and fault generation
- External GPIO detection control with programmable fault generation
- Configurable DPWM fault generation for DPWM Current Limit Fault, DPWM Over-Voltage Detection Fault, DPWM A External Fault, DPWM B External Fault and DPWM IDE Flag
- Clock Failure Detection for High and Low Frequency Oscillator blocks
- Discontinuous Conduction Mode Detection

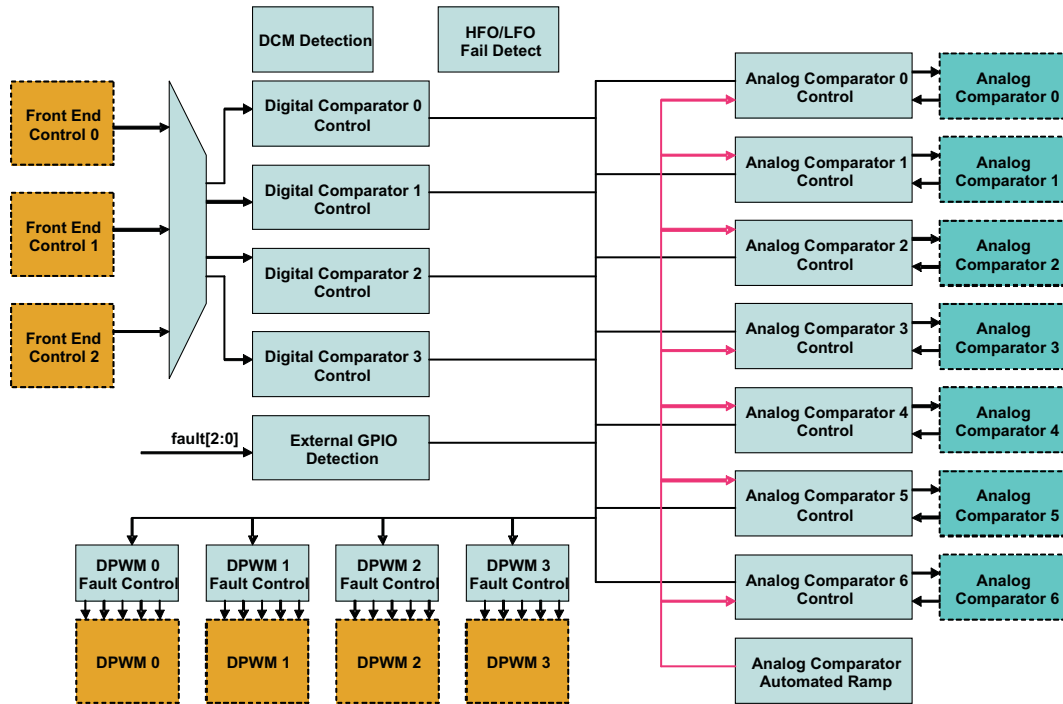

Figure 4-5. Fault Mux Block Diagram

4.15 Communication Ports

4.15.1 SCI (UART) Serial Communication Interface

A maximum of two independent Serial Communication Interface (SCI) or Universal Asynchronous Receiver/Transmitter pre-scaler (UART) interfaces are included within the device for asynchronous start-stop serial data communication (see the pin out sections for details) Each interface has a 24 bit for supporting programmable baud rates and has programmable data word and stop bit options. Half or full duplex operation is configurable through register bits. A loop back feature can also be setup for firmware verification. Both SCI-TX and SCI-RX pin sets can be used as GPIO pins when the peripheral is not being used.

4.15.2 PMBUS

The PMBus Interface supports independent master and slave modes controlled directly by firmware through a processor bus interface. Individual control and status registers enable firmware to send or receive I2C, SMBus or PMBus messages in any of the accepted protocols, in accordance with the I²C Specification, SMBus Specification (Version 2.0) and the PMBUS Power System Management Protocol Specification.

The PMBus interface is controlled through a processor bus interface, utilizing a 32-bit data bus and 6-bit address bus. The PMBus interface is connected to the expansion bus, which features 4 byte write enables, a peripheral select dedicated for the PMBus interface, separated 32-bit data buses for reading and writing of data and active-low write and output enable control signals. In addition, the PMBus Interface connects directly to the I²C/SMBus/PMBus Clock, Data, Alert, and Control signals.

Example: PMBus Address Decode via ADC12 Reading

The user can allocate 2 pins of the 12-bit ADC input channels, AD_00 and AD_01, for PMBus address decoding. At power-up the device applies I_{BIAS} to each address detect pin and the voltage on that pin is captured by the internal 12-bit ADC.

Where bin(V_{AD0x}) is the address bin for one of 12 address as shown in [Figure 4-6](#).

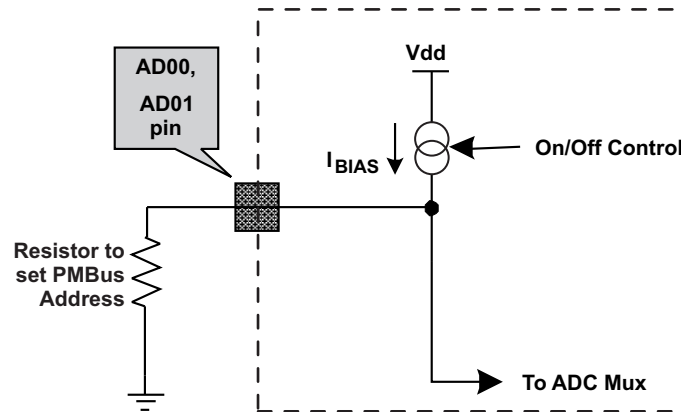

Figure 4-6. PMBus Address Detection Method

4.15.3 General Purpose ADC12

The ADC12 is a 12 bit, high speed analog to digital converter, equipped with the following options:

- Typical conversion speed of 267 ksp/s
- Conversions can consist from 1 to 16 ADC channel conversions in any desired sequence
- Post conversion averaging capability, ranging from 4X, 8X, 16X or 32X samples
- Configurable triggering for ADC conversions from the following sources: firmware, DPWM rising edge, ADC_EXT_TRIG pin or Analog Comparator results
- Interrupt capability to embedded processor at completion of ADC conversion
- Six digital comparators on the first 6 channels of the conversion sequence using either raw ADC data or averaged ADC data
- Two 10 μ A current sources for excitation of PMBus addressing resistors
- Dual sample and hold for accurate power measurement
- Internal temperature sensor for temperature protection and monitoring

The control module ([ADC12 Control Block Diagram](#)) contains the control and conversion logic for auto-sequencing a series of conversions. The sequencing is fully configurable for any combination of 16 possible ADC channels through an analog multiplexer embedded in the ADC12 block. Once converted, the selected channel value is stored in the result register associated with the sequence number. Input channels can be sampled in any desired order or programmed to repeat conversions on the same channel multiple times during a conversion sequence. Selected channel conversions are also stored in the result registers in order of conversion, where the result 0 register is the first conversion of a 16-channel sequence and result 15 register is the last conversion of a 16-channel sequence. The number of channels converted in a sequence can vary from 1 to 16.

Unlike EADC0 through EADC2, which are primarily designed for closing high speed compensation loops, the ADC12 is not usually used for loop compensation purposes. The EADC converters have a substantially faster conversion rate, thus making them more attractive for closed loop control. The ADC12 features make it best suited for monitoring and detection of currents, voltages, temperatures and faults. Please see the [Typical Characteristics plots](#) for the temperature variation associated with this function.

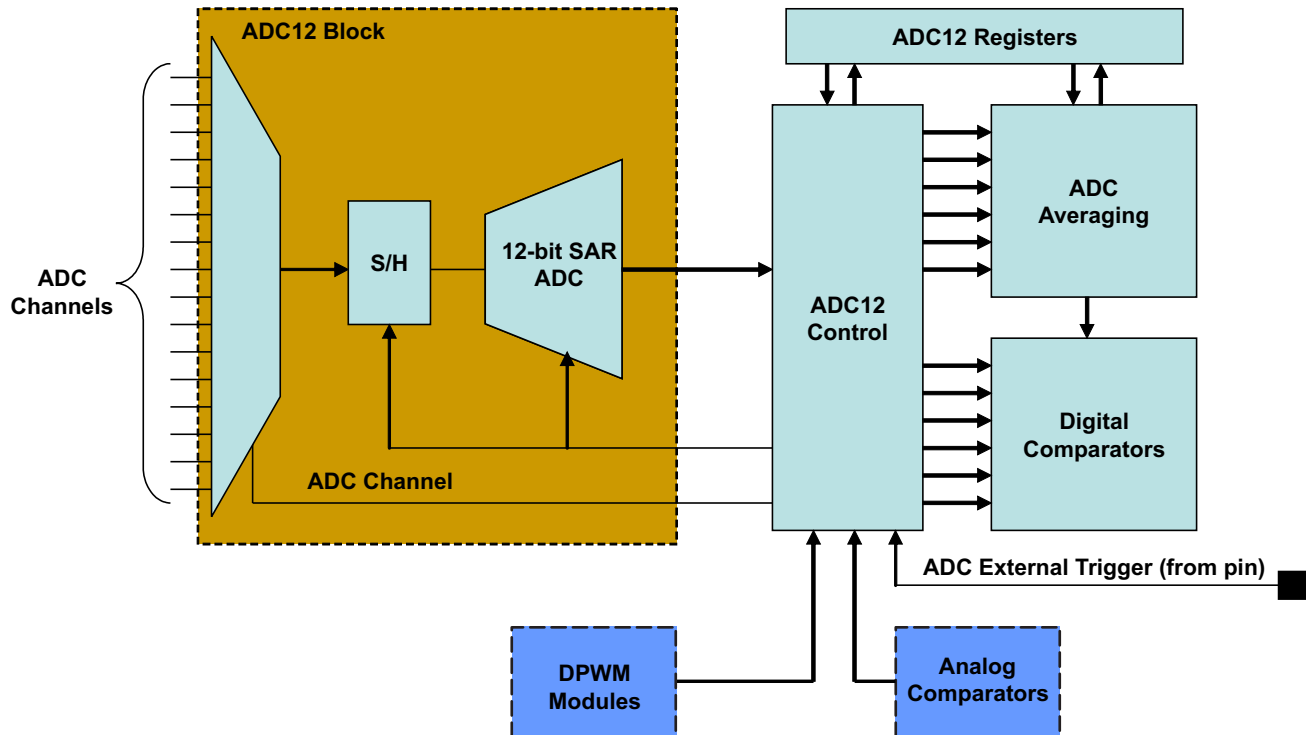

Figure 4-7. ADC12 Control Block Diagram

4.15.4 Timers

External to the Digital Power Peripherals there are 3 different types of timers in UCD3138. They are the 24-bit timer, 16-bit timer and the Watchdog timer

4.15.4.1 24-bit PWM Timer

There is one 24 bit counter PWM timer which runs off the Interface Clock and can further be divided down by an 8-bit pre-scalar to generate a slower PWM time period. The timer has two compare registers (Data Registers) for generating the PWM set/unset events. Additionally, the timer has a shadow register (Data Buffer register) which can be used to store CPU updates of the compare events while still using the timer. The selected shadow register update mode happens after the compare event matches.

The two capture pins TCMP0 and TCMP1 are inputs for recording a capture event. A capture event can be set either to rising, falling, or both edges of the capture pin. Upon this event, the counter value is stored in the corresponding capture data register.

The counter reset can be configured to happen on a counter roll over, a compare equal event, or by software controlled register. Five Interrupts from the PWM timer can be set, which are the counter rollover event (overflow), either capture event 0 or 1, or the two comparison match events. Each interrupt can be disabled or enabled.

Upon an event comparison on only the second event, the TCMP pin can be configured to set, clear, toggle or have no action at the output. The value of PWM pin output can be read for status or simply configured as general purpose I/O for reading the value of the input at the pin. The first compare event can only be used as an interrupt.

4.15.4.2 16-Bit PWM Timers

There are four 16 bit counter PWM timers which run off the Interface Clock and can further be divided down by a 8-bit pre-scaler to generate slower PWM time periods. Each timer has two compare registers (Data Registers) for generating the PWM set/unset events. Additionally, each timer has a shadow register (Data Buffer register) which can be used to store CPU updates of compare events while still using the timer. The selected shadow register update mode happens after the compare event matches.

The counter reset can be configured to happen on a counter roll over, a compare equal event, or by a software controlled register. Interrupts from the PWM timer can be set due to the counter rollover event (overflow) or by the two comparison match events. Each comparison match and the overflow interrupts can be disabled or enabled.

Upon an event comparison, the PWM pin can be configured to set, clear, toggle or have no action at the output. The value of PWM pin output can be read for status or simply configured as General Purpose I/O for reading the value of the input at the pin.

4.15.4.3 Watchdog Timer

A watchdog timer is provided on the device for ensuring proper firmware loop execution. The timer is clocked off of a separate low speed oscillator source. If the timer is allowed to expire, a reset condition is issued to the ARM processor. The watchdog is reset by a simple CPU write bit to the watchdog key register by the firmware routine. On device power-up the watchdog is disabled. Yet after it is enabled, the watchdog cannot be disabled by firmware. Only a device reset can put this bit back to the default disabled state. A half timer flag is also provided for status monitoring of the watchdog.

4.16 Miscellaneous Analog

The Miscellaneous Analog Control (MAC) Registers are a catch-all of registers that control and monitor a wide variety of functions. These functions include device supervisory features such as Brown-Out and power saving configuration, general purpose input/output configuration and interfacing, internal temperature sensor control and current sharing control.

The MAC module also provides trim signals to the oscillator and AFE blocks. These controls are usually used at the time of trimming at manufacturing; therefore this document will not cover these trim controls.

The MAC registers and peripherals are all available in the UCD3138 (64 pin version). Other UCD3138 devices may have reduced resources. See the device pin out description for details.

4.17 Package ID Information

Package ID register includes information regarding the package type of the device and can be read by firmware for reporting through PMBus or for other package sensitive decisions.

BIT NUMBER	1:0
Bit Name	PKG_ID
Access	R/W
Default	0 – UCD3138RGC, 1 – UCD3138RHA

4.18 Brownout

Brownout function is used to determine if the device supply voltage is lower than a threshold voltage, a condition that may be considered unsafe for proper operation of the device.

The brownout threshold is higher than the reset threshold voltage; therefore, when the supply voltage is lower than brownout threshold, it still does not necessarily trigger a device reset.

The brownout interrupt flag can be polled or alternatively can trigger an interrupt to service such case by an interrupt service routine. Please see the [Power On Reset \(POR\) / Brown Out Reset \(BOR\)](#) section.

4.19 Global I/O

Up to 30 pins in UCD3138 can be configured to serve as a general purpose input or output pin (GPIO). This includes all digital input or output pins except for the RESET pin.

The pins that cannot be configured as GPIO pins are the supply pins, ground pins, ADC-12 analog input pins, EADC analog input pins and the RESET pin.

There are two ways to configure and use the digital pins as GPIO pins:

1. Through the centralized Global I/O control registers.
2. Through the distributed control registers in the specific peripheral that shares it pins with the standard GPIO functionality.

The Global I/O registers offer full control of:

1. Configuring each pin as a GPIO.
2. Setting each pin as input or output.
3. Reading the pin's logic state, if it is configured as an input pin.
4. Setting the logic state of the pin, if it is configured as an output pin.
5. Connecting pin/pins to high rail through internal pull up resistors.

The Global I/O registers include Global I/O EN register, Global I/O OE Register, Global I/O Open Drain Control Register, Global I/O Value Register and Global I/O Read Register.

The following is showing the format of Global I/O EN Register (GLBIOEN) as an example:

BIT NUMBER	29:0
Bit Name	GLOBAL_IO_EN
Access	R/W
Default	00_0000_0000_0000_0000_0000_0000_0000

Bits 29-0: GLOBAL_IO_EN – This register enables the global control of digital I/O pins
0 = Control of IO is done by the functional block assigned to the IO (Default)
1 = Control of IO is done by Global IO registers.

BIT	PIN_NAME	PIN NUMBER	
		UCD3138-64 PIN	UCD3138-40 PIN
29	FAULT[3]	43	NA
28	ADC_EXT_TRIG	12, 26	8
27	TCK	37	21
26	TDO	38	20
25	TMS	40	24
24	TDI	39	23
23	SCI_TX[1]	29	NA
22	SCI_TX[0]	14	22
21	SCI_RX[1]	30	NA
20	SCI_RX[0]	13	23
19	TMR_CAP	12, 26, 41	8, 21
18	TMR_PWM[1]	32	NA
17	TMR_PWM[0]	12, 26, 31, 37	21
16	PMBUS-CLK	15	9
15	PMBUS-DATA	16	10
14	CONTROL	30	20
13	ALERT	29	19
12	EXT_INT	26, 34	NA

BIT	PIN_NAME	PIN NUMBER	
		UCD3138-64 PIN	UCD3138-40 PIN
11	FAULT[2]	42	25
10	FAULT[1]	36	23
9	FAULT[0]	35, 39	22
8	SYNC	12, 26,37	8, 21
7	DPWM3B	24	18
6	DPWM3A	23	17
5	DPWM2B	22	16
4	DPWM2A	21	15
3	DPWM1B	20	14
2	DPWM1A	19	13
1	DPWM0B	18	12
0	DPWM0A	17	11

4.20 Temperature Sensor Control

Temperature sensor control register provides internal temperature sensor enabling and trimming capabilities. The internal temperature sensor is disabled as default.

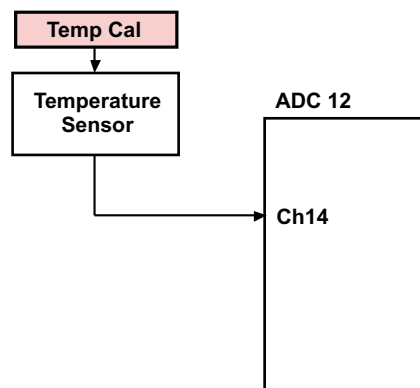

Figure 4-8. Internal Temp Sensor

Temperature sensor is calibrated at room temperature (25 °C) via a calibration register value.

The temperature sensor is measured using ADC12 (via Ch14). The temperature is then calculated using a mathematical formula involving the calibration register (this effectively adds a delta to the ADC measurement).

The temperature sensor can be enabled or disabled.

4.21 I/O Mux Control

In different packages of UCD3138 several I/O functions are multiplexed and routed toward a single physical pin. I/O Mux Control register may be used in order to choose a single specific functionality that is desired to be assigned to a physical device pin for your application.

4.21.1 JTAG Use for I/O and JTAG Security

The UCD3138 provides a JTAG interface for debugging and for uploading data and programs. The pins are multiplexed with other pins, and will not be available in certain topologies. For power supplies, other debugging techniques (PMBus, UART, code instrumentation) are often superior to JTAG. Code downloading is much faster via PMBus, or with a user boot program via UART. PMBus support is available from TI. JTAG for debugging has limited support from TI's Code Composer Studio. JTAG parameter download may be supported by third parties.

4.22 Current Sharing Control

UCD3138 provides three separate modes of current sharing operation.

- Analog bus current sharing
- PWM bus current sharing
- Master/Slave current sharing
- AD02 has a special ESD protection mechanism that prevents the pin from pulling down the current-share bus if power is missing from the UCD3138

The simplified current sharing circuitry is shown in the drawing below:

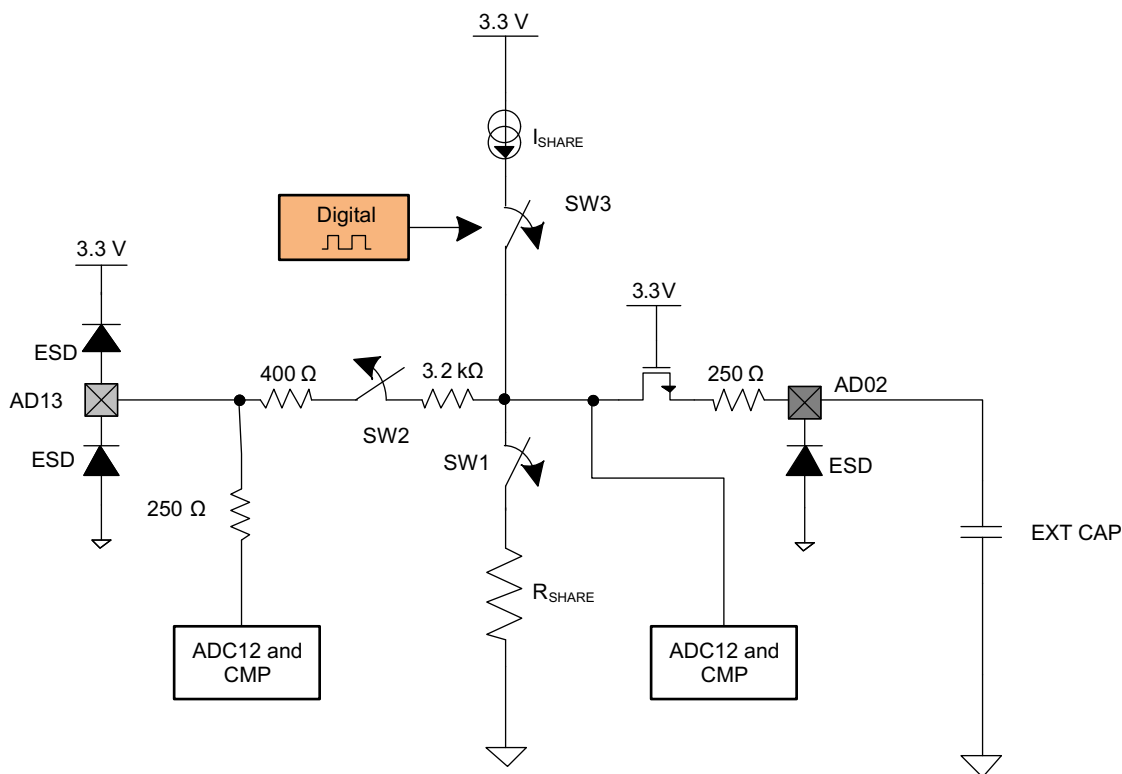

Figure 4-9. Simplified Current Sharing Circuitry

CURRENT SHARING MODE	FOR TEST ONLY, ALWAYS KEEP 00	CS_MODE	EN_SW1	EN_SW2	DPWM
Off or Slave Mode (3-state)	00	00 (default)	0	0	0
PWM Bus	00	01	1	0	ACTIVE
Off or Slave Mode (3-state)	00	10	0	0	0
Analog Bus or Master	00	11	0	1	0

The period and the duty of 8-bit PWM current source and the state of the SW1 and SW2 switches can be controlled through the current sharing control register (CSCTRL).

4.23 Temperature Reference

The temperature reference register (TEMPREF) provides the ADC12 count when ADC12 measures the internal temperature sensor (channel 14) during the factory trim and calibration.

This information can be used by different periodic temperature compensation routines implemented in the firmware. But it should not be overwritten by firmware, otherwise this factory written value will be lost.

5 IC Grounding and Layout Recommendations

- Two grounds are recommended: AGND (analog) and DGND (digital).
 - AGND plane should be on a different layer than DGND, and right under the UCD3138 device.
 - UCD3138 power pad should be tied to AGND plane by at least 4 vias
 - AGND plane should be just large enough to connect to all required components.
 - Power ground (PGND) can be independent or combined with DGND
 - The power pad of the driver IC should be tied to DGND
- Both 3.3VD and 3.3VA should have a local 4.7 μ F capacitor placed as close as possible to the device pins
- BPCAP decoupling (2.2 μ F typically) **MUST** be connected to DGND

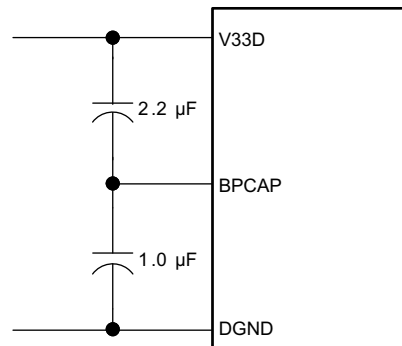

- All analog signal filter capacitors should be tied to AGND
 - If the gate driver device, such as UCD27524 or UCD27511/7 driver is used, the filter capacitor for the current sensing pin can be tied to DGND for easy layout
- All digital signals, such as GPIO, PMBus and PWM are referenced to DGND.
- The RESET pin capacitor (0.1 μ F) should be connected to either DGND or AGND locally. A 10k Ω pull-up resistor to 3.3V is recommended.
- All filter and decoupling capacitors should be placed close to UCD3138 as possible
 - Resistor placement is less critical and can be moved a little further away
- The DGND and AGND net-short resistor **MUST** be placed right between one UCD3138's DGND pin and one AGND pin. Ground connections to the net short element should be made by a large via (or multiple paralleled vias) for each terminal of the net-short element.
- If a gate driver device such as UCC27524 or UCC27511/7 is on the control card and there is a PGND connection, a net-short resistor should be tied to the DGND plane and PGND plane by multiple vias. In addition the net-short element should be close to the driver IC.

6 Tools and Documentation

The application firmware for UCD3138 is developed on Texas Instruments Code Composer Studio (CCS) integrated development environment (v3.3 recommended).

Monitoring and Configuration of key device parameters and real time debug capabilities are offered through Texas Instruments' FUSION_DIGITAL_POWER_DESIGNER Graphical User Interface (GUI), http://www.ti.com/tool/fusion_digital_power_designer.

The FUSION_DIGITAL_POWER_DESIGNER software application uses PMBus protocol to communicate with the device over serial bus by way of a interface adaptor known as USB-TO-GPIO, available as an EVM from Texas Instruments (<http://www.ti.com/tool/usb-to-gpio>).

The software application can also be used to program the devices, with a version of the tool known as FUSION_MFR_GUI optimized for manufacturing environments (http://www.ti.com/tool/fusion_mfr_gui). The FUSION_MFR_GUI tool supports multiple devices on a board, and includes built-in logging and reporting capabilities.

In terms of reference documentation, the following 3 programmer's manuals are available offering detailed information regarding the application and usage of UCD3138 digital controller:

1. UCD3138 Digital Power Peripheral Programmer's Manual Key topics covered in this manual include:

- Digital Pulse Width Modulator (DPWM)
 - Modes of Operation (Normal/Multi/Phase-shift/Resonant etc)
 - Automatic Mode Switching
 - DPWMC, Edge Generation & Intra-Mux
- Front End
 - Analog Front End
 - Error ADC or EADC
 - Front End DAC
 - Ramp Module
 - Successive Approximation Register Module
- Filter
 - Filter Math
- Loop Mux
 - Analog Peak Current Mode
 - Constant Current/Constant Power (CCCP)
 - Automatic Cycle Adjustment
- Fault Mux
 - Analog Comparators
 - Digital Comparators
 - Fault Pin functions
 - DPWM Fault Action
 - Ideal Diode Emulation (IDE), DCM Detection
 - Oscillator Failure Detection
- Register Map for all of the above peripherals in UCD3138

2. UCD3138 Monitoring and Communications Programmer's Manual

Key topics covered in this manual include:

- ADC12
 - Control, Conversion, Sequencing & Averaging
 - Digital Comparators
 - Temperature Sensor
 - PMBUS Addressing
 - Dual Sample & Hold
- Miscellaneous Analog Controls (Current Sharing, Brown-Out, Clock-Gating)
- PMBUS Interface
- General Purpose Input Output (GPIO)

- Timer Modules
 - PMBus
 - Register Map for all of the above peripherals in UCD3138
3. UCD3138 ARM and Digital System Programmer's Manual
Key topics covered in this manual include:
- Boot ROM & Boot Flash
 - BootROM Function
 - Memory Read/Write Functions
 - Checksum Functions
 - Flash Functions
 - Avoiding Program Flash Lock-Up
 - ARM7 Architecture
 - Modes of Operation
 - Hardware/Software Interrupts
 - Instruction Set
 - Dual State Inter-working (Thumb 16-bit Mode/ARM 32-bit Mode)
 - Memory & System Module
 - Address Decoder, DEC (Memory Mapping)
 - Memory Controller (MMC)
 - Central Interrupt Module
 - Register Map for all of the above peripherals in UCD3138

In addition to the tools and documentation described above, for the most up to date information regarding evaluation modules, reference application firmware and application notes/design tips, please visit <http://www.ti.com/product/ucd3138>.

7 References

1. UCD3138 Digital Power Peripherals Programmer's Manual (Literature Number: [SLUU995](#))
2. UCD3138 Monitoring & Communications Programmer's Manual (Literature Number: [SLUU996](#))
3. UCD3138 ARM and Digital System Programmer's Manual (Literature Number: [SLUU994](#))
4. Code Composer Studio Development Tools v3.3 – Getting Started Guide, (Literature Number: [SPRU509H](#))
5. ARM7TDMI-S Technical Reference Manual
6. System Management Bus (SMBus) Specification
7. PMBus™ Power System Management Protocol Specification ⁽¹⁾

(1) PMBus is a trademark of SMIF, Inc.

Revision History

NOTE: Page numbers for previous revisions may differ from page numbers in the current version.

Changes from Original (March 2012) to Revision A		Page
• Added 将生产数据声明添加到脚注并删除了“产品预览”标题栏		6

Changes from Revision A (March 2012) to Revision B		Page
• Added 特性着重号		6
• Changed 在特性部分中将“双边沿调制”改为“三角调制”		6
• Changed 在特性部分中将“265kbps”改为“267kbps”		6
• 在特性部分明确了通用异步收发器 (UART) 的数量		6
• Changed 在全文中将“FDPP”改为“DPP”。		7
• Changed 在产品选择矩阵表中将 UCD3138 40 引脚器件的通用输入输出 (GPIO) 引脚总数从“17”改为“18”。		8
• Changed "VREG" to "BP18" in conditions statement for Electrical Characteristics table.		16
• Changed EAP – EAN Error voltage digital resolution MIN values for AFE=3, AFE=2, AFE=1, AFE=0 from 0.95, 1.90, 3.72, and 7.3 respectively; to, 0.8, 1.7, 3.55, and 6.90 respectively.		16
• Changed "VREG" to "BP18" in conditions statement for Electrical Characteristics table.		17
• Changed conditions for V_{OL} and V_{OH} specs in the Electrical Characteristics table		17
• Added TWD spec to Electrical Characteristics table		17
• Changed "VREG" to "BP18" in conditions statement for Electrical Characteristics table.		18
• Changed "PWM" to "DPWM" in DPWM Module.		29
• Changed "PWMA" and "PWMB" to "DPWMA" and "DPWMB" in		34
• Changed waveforms graphic for "Phase Shifted Full Bridge Example" for clarification		41
• Added text to section LLC Example		42
• Changed typical conversion speed from "268 ksp/s" to "267 ksp/s" in the General Purpose ADC12 section.		52
• Added package ID information for the UCD3138RGC and UCD3138RHA devices.		54
• Added bullet "AD02 has a special ESD protection mechanism that prevents the pin from pulling down the current-share bus if power is missing from the UCD3138" to Current Sharing Control .		57
• Added sub-bullet "The power pad of the driver IC should be tied to DGND" and changed capacitor value from "0.1 μ F" to "4.7 μ F" in IC Grounding and Layout Recommendations		59
• Added "Tools and Documentation" section		60
• Changed " Mechanical Data" section to "References" section		62

PACKAGING INFORMATION

Orderable Device	Status ⁽¹⁾	Package Type	Package Drawing	Pins	Package Qty	Eco Plan ⁽²⁾	Lead/ Ball Finish	MSL Peak Temp ⁽³⁾	Samples (Requires Login)
UCD3138RGCR	ACTIVE	VQFN	RGC	64	2000	Green (RoHS & no Sb/Br)	CU NIPDAU	Level-3-260C-168 HR	
UCD3138RGCT	ACTIVE	VQFN	RGC	64	250	Green (RoHS & no Sb/Br)	CU NIPDAU	Level-3-260C-168 HR	
UCD3138RHAR	ACTIVE	VQFN	RHA	40	2500	Green (RoHS & no Sb/Br)	CU NIPDAU	Level-3-260C-168 HR	
UCD3138RHAT	ACTIVE	VQFN	RHA	40	250	Green (RoHS & no Sb/Br)	CU NIPDAU	Level-3-260C-168 HR	

⁽¹⁾ The marketing status values are defined as follows:

ACTIVE: Product device recommended for new designs.

LIFEBUY: TI has announced that the device will be discontinued, and a lifetime-buy period is in effect.

NRND: Not recommended for new designs. Device is in production to support existing customers, but TI does not recommend using this part in a new design.

PREVIEW: Device has been announced but is not in production. Samples may or may not be available.

OBSOLETE: TI has discontinued the production of the device.

⁽²⁾ Eco Plan - The planned eco-friendly classification: Pb-Free (RoHS), Pb-Free (RoHS Exempt), or Green (RoHS & no Sb/Br) - please check <http://www.ti.com/productcontent> for the latest availability information and additional product content details.

TBD: The Pb-Free/Green conversion plan has not been defined.

Pb-Free (RoHS): TI's terms "Lead-Free" or "Pb-Free" mean semiconductor products that are compatible with the current RoHS requirements for all 6 substances, including the requirement that lead not exceed 0.1% by weight in homogeneous materials. Where designed to be soldered at high temperatures, TI Pb-Free products are suitable for use in specified lead-free processes.

Pb-Free (RoHS Exempt): This component has a RoHS exemption for either 1) lead-based flip-chip solder bumps used between the die and package, or 2) lead-based die adhesive used between the die and leadframe. The component is otherwise considered Pb-Free (RoHS compatible) as defined above.

Green (RoHS & no Sb/Br): TI defines "Green" to mean Pb-Free (RoHS compatible), and free of Bromine (Br) and Antimony (Sb) based flame retardants (Br or Sb do not exceed 0.1% by weight in homogeneous material)

⁽³⁾ MSL, Peak Temp. -- The Moisture Sensitivity Level rating according to the JEDEC industry standard classifications, and peak solder temperature.

Important Information and Disclaimer: The information provided on this page represents TI's knowledge and belief as of the date that it is provided. TI bases its knowledge and belief on information provided by third parties, and makes no representation or warranty as to the accuracy of such information. Efforts are underway to better integrate information from third parties. TI has taken and continues to take reasonable steps to provide representative and accurate information but may not have conducted destructive testing or chemical analysis on incoming materials and chemicals. TI and TI suppliers consider certain information to be proprietary, and thus CAS numbers and other limited information may not be available for release.

In no event shall TI's liability arising out of such information exceed the total purchase price of the TI part(s) at issue in this document sold by TI to Customer on an annual basis.

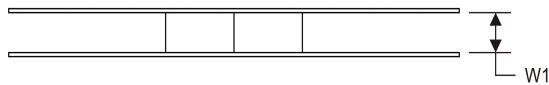
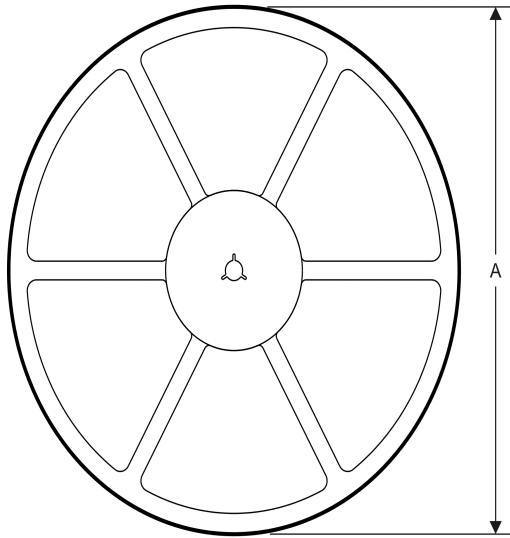
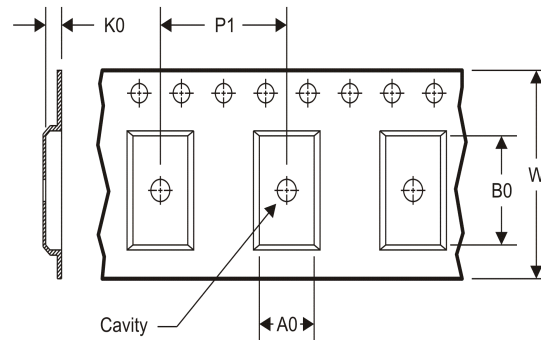
TAPE AND REEL INFORMATION
REEL DIMENSIONS

TAPE DIMENSIONS

A0	Dimension designed to accommodate the component width
B0	Dimension designed to accommodate the component length
K0	Dimension designed to accommodate the component thickness
W	Overall width of the carrier tape
P1	Pitch between successive cavity centers

TAPE AND REEL INFORMATION

*All dimensions are nominal

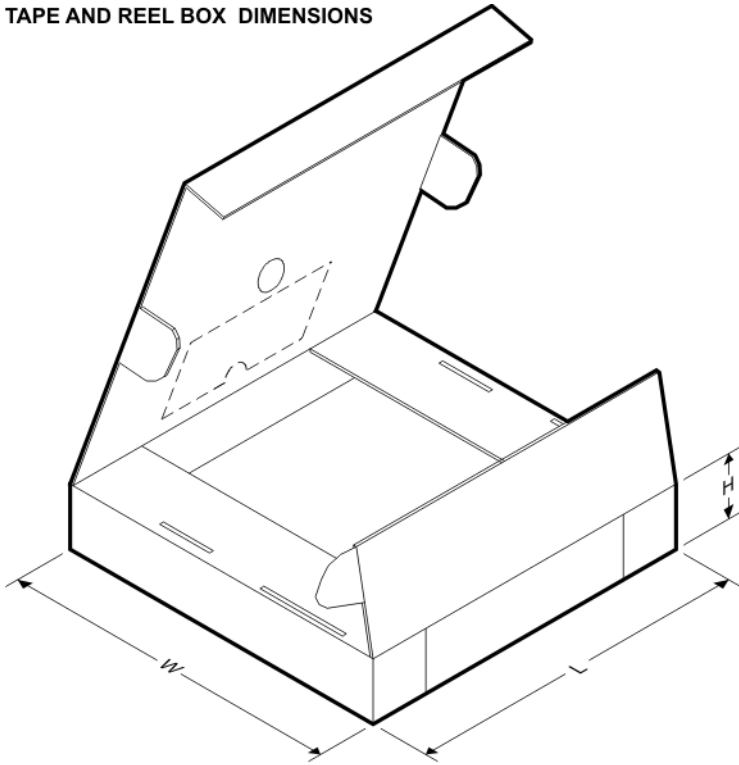
Device	Package Type	Package Drawing	Pins	SPQ	Reel Diameter (mm)	Reel Width W1 (mm)	A0 (mm)	B0 (mm)	K0 (mm)	P1 (mm)	W (mm)	Pin1 Quadrant
UCD3138RGCR	VQFN	RGC	64	2000	330.0	16.4	9.3	9.3	1.5	12.0	16.0	Q2
UCD3138RGCT	VQFN	RGC	64	250	180.0	16.4	9.3	9.3	1.5	12.0	16.0	Q2
UCD3138RHAR	VQFN	RHA	40	2500	330.0	16.4	6.3	6.3	1.5	12.0	16.0	Q2
UCD3138RHAT	VQFN	RHA	40	250	180.0	16.4	6.3	6.3	1.5	12.0	16.0	Q2

TAPE AND REEL BOX DIMENSIONS

*All dimensions are nominal

Device	Package Type	Package Drawing	Pins	SPQ	Length (mm)	Width (mm)	Height (mm)
UCD3138RGCR	VQFN	RGC	64	2000	367.0	367.0	38.0
UCD3138RGCT	VQFN	RGC	64	250	210.0	185.0	35.0
UCD3138RHAR	VQFN	RHA	40	2500	367.0	367.0	38.0
UCD3138RHAT	VQFN	RHA	40	250	210.0	185.0	35.0

MECHANICAL DATA

RGC(S-PVQFN-N64) CUSTOM DEVICE PLASTIC QUAD FLATPACK NO-LEAD

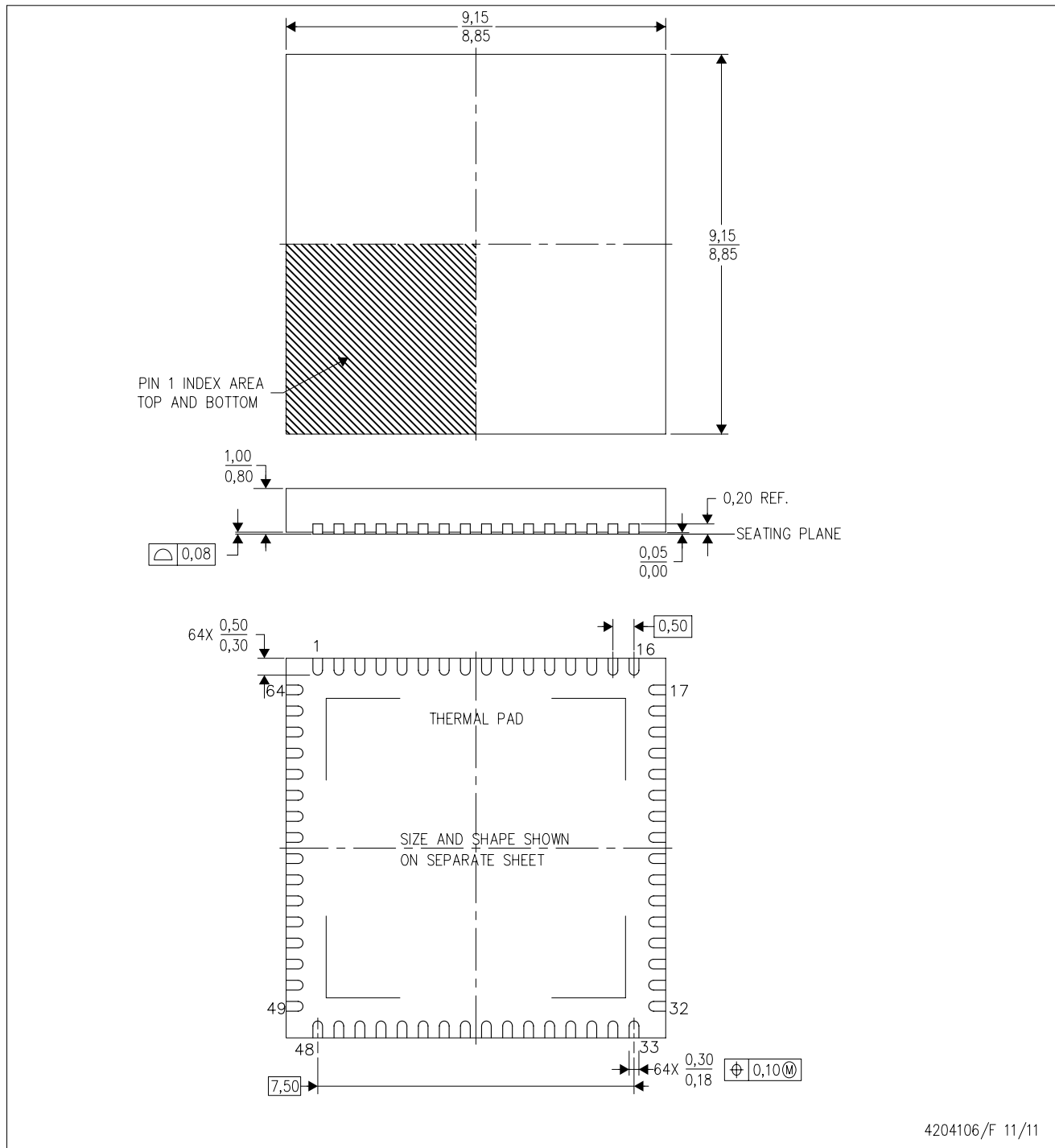

- NOTES:
- All linear dimensions are in millimeters. Dimensioning and tolerancing per ASME Y14.5-1994.
 - This drawing is subject to change without notice.
 - Quad Flatpack, No-leads (QFN) package configuration.
 - The package thermal pad must be soldered to the board for thermal and mechanical performance.
 - See the additional figure in the Product Data Sheet for details regarding the exposed thermal pad features and dimensions.

THERMAL PAD MECHANICAL DATA

RGC (S-PVQFN-N64)

PLASTIC QUAD FLATPACK NO-LEAD

THERMAL INFORMATION

This package incorporates an exposed thermal pad that is designed to be attached directly to an external heatsink. The thermal pad must be soldered directly to the printed circuit board (PCB). After soldering, the PCB can be used as a heatsink. In addition, through the use of thermal vias, the thermal pad can be attached directly to the appropriate copper plane shown in the electrical schematic for the device, or alternatively, can be attached to a special heatsink structure designed into the PCB. This design optimizes the heat transfer from the integrated circuit (IC).

For information on the Quad Flatpack No-Lead (QFN) package and its advantages, refer to Application Report, QFN/SON PCB Attachment, Texas Instruments Literature No. SLUA271. This document is available at www.ti.com.

The exposed thermal pad dimensions for this package are shown in the following illustration.

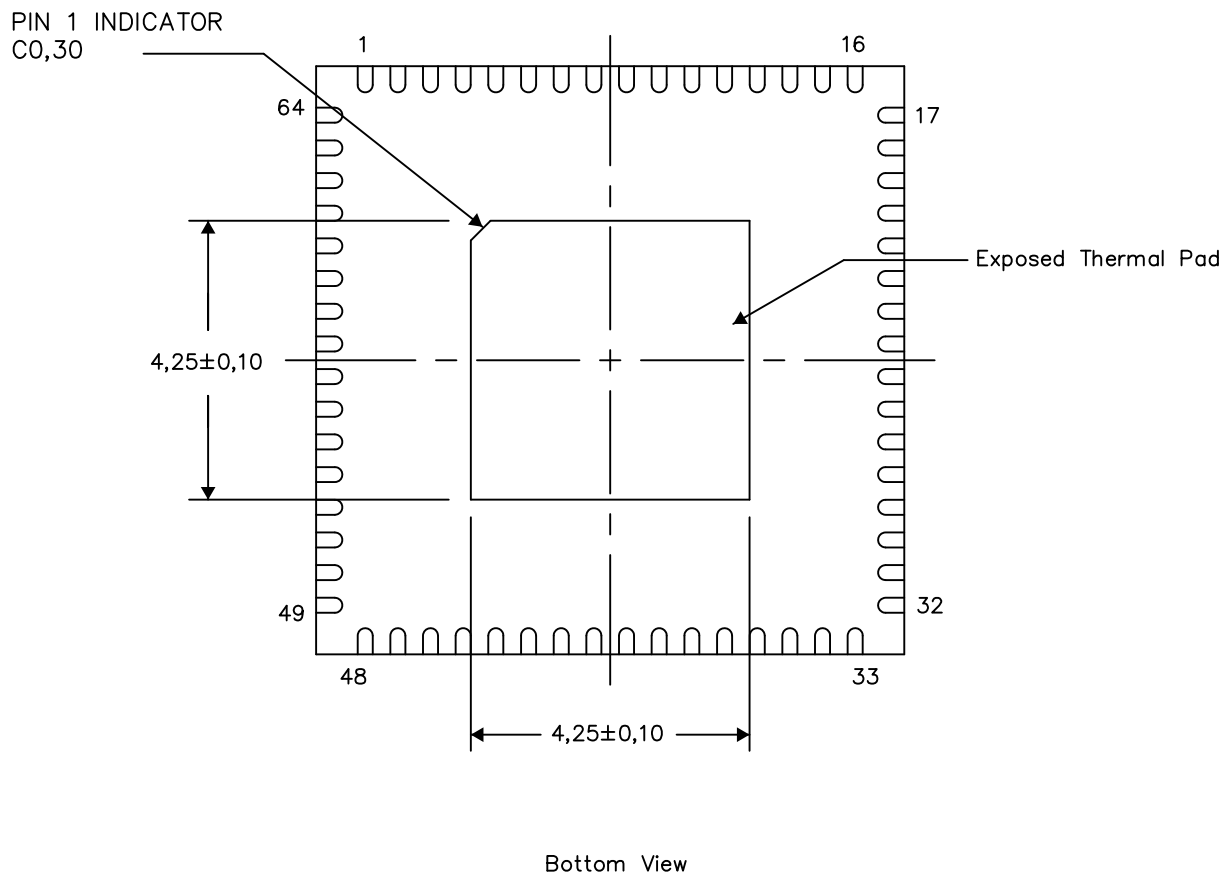

Exposed Thermal Pad Dimensions

4206192-3/T 08/12

NOTE: A. All linear dimensions are in millimeters

RGC (S-PVQFN-N64)

PLASTIC QUAD FLATPACK NO-LEAD

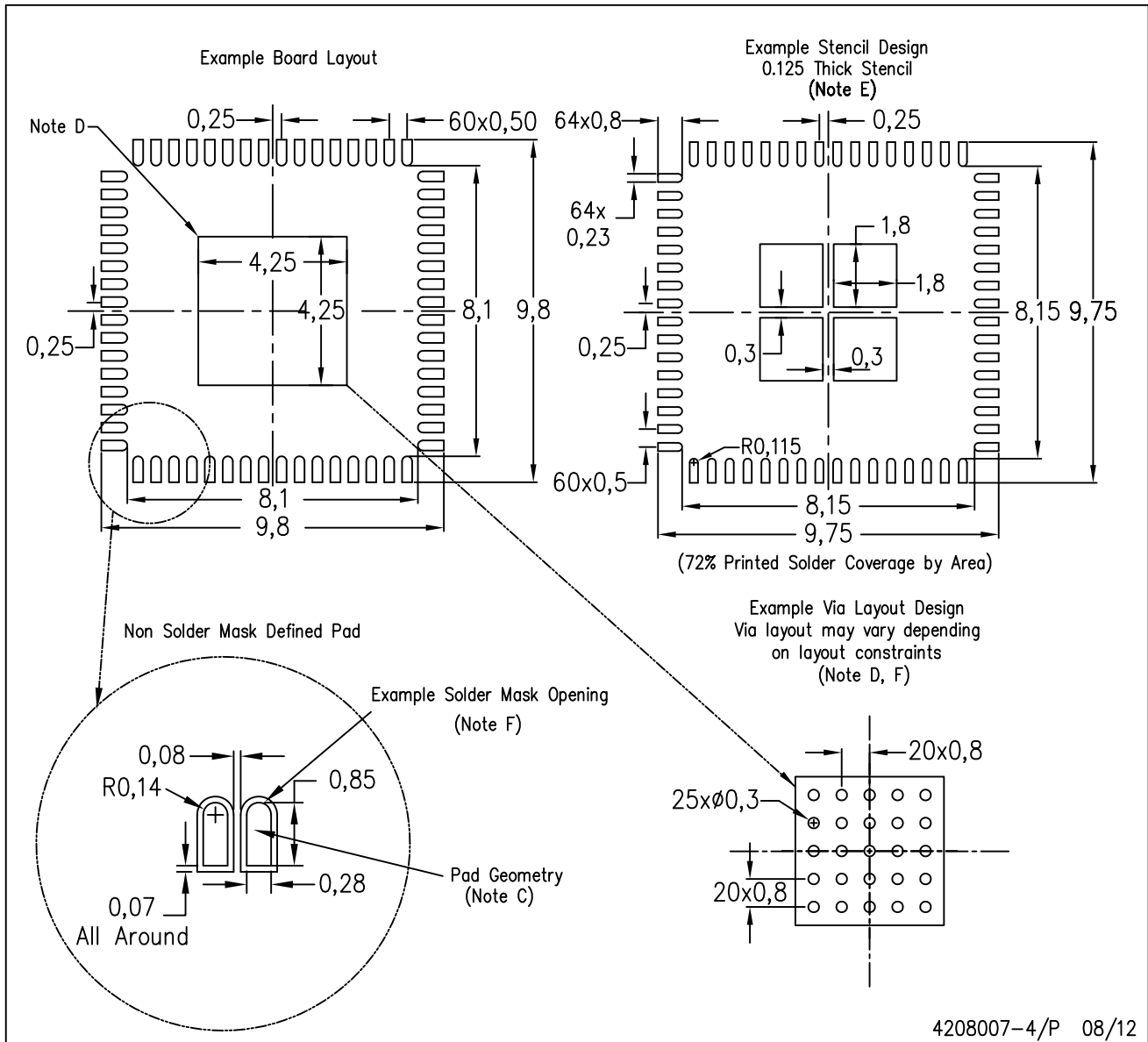

- NOTES:
- A. All linear dimensions are in millimeters.
 - B. This drawing is subject to change without notice.
 - C. Publication IPC-7351 is recommended for alternate designs.
 - D. This package is designed to be soldered to a thermal pad on the board. Refer to Application Note, Quad Flat-Pack Packages, Texas Instruments Literature No. SLUA271, and also the Product Data Sheets for specific thermal information, via requirements, and recommended board layout. These documents are available at www.ti.com <<http://www.ti.com>>.
 - E. Laser cutting apertures with trapezoidal walls and also rounding corners will offer better paste release. Customers should contact their board assembly site for stencil design recommendations. Refer to IPC 7525 for stencil design considerations.
 - F. Customers should contact their board fabrication site for recommended solder mask tolerances and via tenting recommendations for vias placed in thermal pad.

RHA (S-PVQFN-N40)

PLASTIC QUAD FLATPACK NO-LEAD

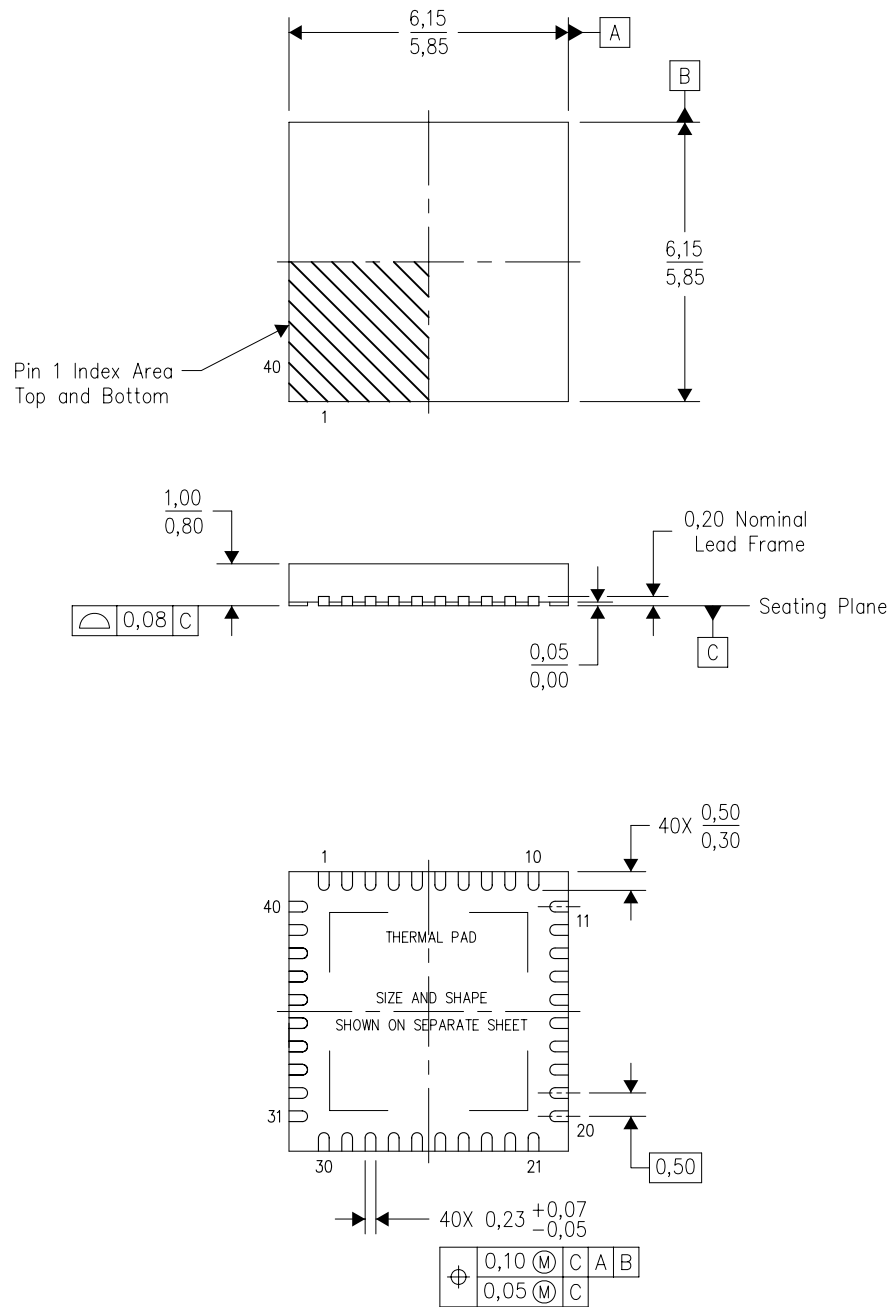

Bottom View

4204276/E 06/11

- NOTES:
- All linear dimensions are in millimeters. Dimensioning and tolerancing per ASME Y14.5M-1994.
 - This drawing is subject to change without notice.
 - QFN (Quad Flatpack No-Lead) Package configuration.
 - The package thermal pad must be soldered to the board for thermal and mechanical performance.
 - See the additional figure in the Product Data Sheet for details regarding the exposed thermal pad features and dimensions.
 - Package complies to JEDEC MO-220 variation VJJD-2.

RHA (S-PVQFN-N40)

PLASTIC QUAD FLATPACK NO-LEAD

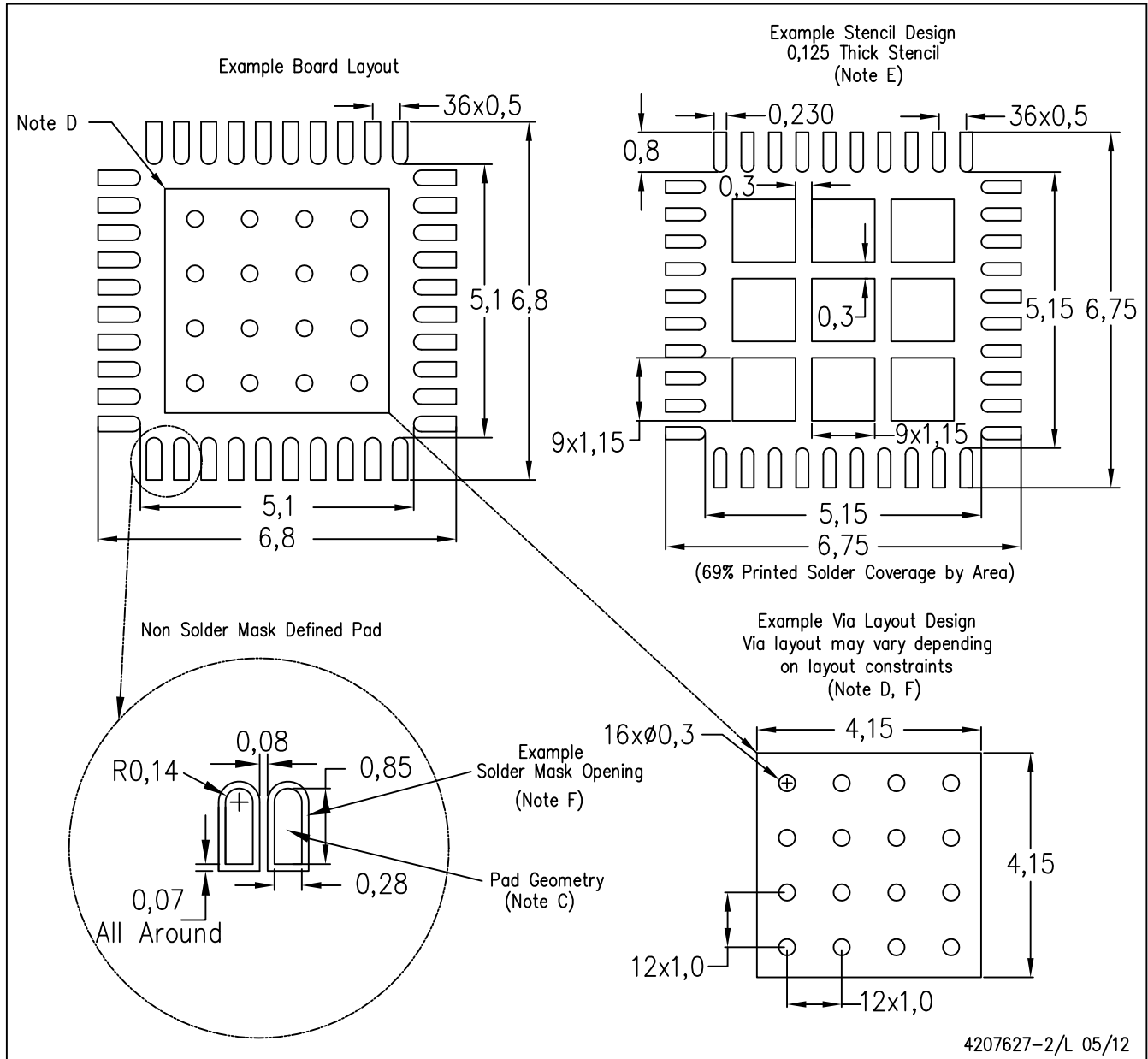

- NOTES:
- All linear dimensions are in millimeters.
 - This drawing is subject to change without notice.
 - Publication IPC-7351 is recommended for alternate designs.
 - This package is designed to be soldered to a thermal pad on the board. Refer to Application Note, Quad Flat-Pack Packages, Texas Instruments Literature No. SLUA271, and also the Product Data Sheets for specific thermal information, via requirements, and recommended board layout. These documents are available at www.ti.com <<http://www.ti.com>>.
 - Laser cutting apertures with trapezoidal walls and also rounding corners will offer better paste release. Customers should contact their board assembly site for stencil design recommendations. Refer to IPC 7525 for stencil design considerations.
 - Customers should contact their board fabrication site for recommended solder mask tolerances and via tenting recommendations for vias placed in the thermal pad.

重要声明

德州仪器(TI) 及其下属子公司有权在不事先通知的情况下, 随时对所提供的产品和服务进行更正、修改、增强、改进或其它更改, 并有权随时中止提供任何产品和服务。客户在下订单前应获取最新的相关信息, 并验证这些信息是否完整且是最新的。所有产品的销售都遵循在订单确认时所提供的TI 销售条款与条件。

TI 保证其所销售的硬件产品的性能符合TI 标准保修的适用规范。仅在TI 保证的范围内, 且TI 认为有必要时才会使用测试或其它质量控制技术。除非政府做出了硬性规定, 否则没有必要对每种产品的所有参数进行测试。

TI 对应用帮助或客户产品设计不承担任何义务。客户应对其使用TI 组件的产品和应用自行负责。为尽量减小与客户产品和应用相关的风险, 客户应提供充分的设计与操作安全措施。

TI 不对任何TI 专利权、版权、屏蔽作品权或其它与使用了TI 产品或服务的组合设备、机器、流程相关的TI 知识产权中授予的直接或隐含权限作出任何保证或解释。TI 所发布的与第三方产品或服务有关的信息, 不能构成从TI 获得使用这些产品或服务的许可、授权、或认可。使用此类信息可能需要获得第三方的专利权或其它知识产权方面的许可, 或是TI 的专利权或其它知识产权方面的许可。

对于TI 的产品手册或数据表, 仅在没有对内容进行任何篡改且带有相关授权、条件、限制和声明的情况下才允许进行复制。在复制信息的过程中对内容的篡改属于非法的、欺诈性商业行为。TI 对此类篡改过的文件不承担任何责任。

在转售TI 产品或服务时, 如果存在对产品或服务参数的虚假陈述, 则会失去相关TI 产品或服务的明示或暗示授权, 且这是非法的、欺诈性商业行为。TI 对此类虚假陈述不承担任何责任。

TI 产品未获得用于关键的安全应用中的授权, 例如生命支持应用(在该类应用中一旦TI 产品故障将预计造成重大的人员伤亡), 除非各方官员已经达成了专门管控此类使用的协议。购买者的购买行为即表示, 他们具备有关其应用安全以及规章衍生所需的所有专业技术和知识, 并且认可和同意, 尽管任何应用相关信息或支持仍可能由TI 提供, 但他们将独力负责满足在关键安全应用中使用其产品及TI 产品所需的所有法律、法规和安全相关要求。此外, 购买者必须全额赔偿因在此类关键安全应用中使用TI 产品而对TI 及其代表造成的损失。

TI 产品并非设计或专门用于军事/航空应用, 以及环境方面的产品, 除非TI 特别注明该产品属于“军用”或“增强型塑料”产品。只有TI 指定的军用产品才满足军用规格。购买者认可并同意, 对TI 未指定军用的产品进行军事方面的应用, 风险由购买者单独承担, 并且独力负责在此类相关使用中满足所有法律和法规要求。

TI 产品并非设计或专门用于汽车应用以及环境方面的产品, 除非TI 特别注明该产品符合ISO/TS 16949 要求。购买者认可并同意, 如果他们在汽车应用中使用任何未被指定的产品, TI 对未能满足应用所需要求不承担任何责任。

可访问以下URL 地址以获取有关其它TI 产品和应用解决方案的信息:

	产品		应用
数字音频	www.ti.com.cn/audio	通信与电信	www.ti.com.cn/telecom
放大器和线性器件	www.ti.com.cn/amplifiers	计算机及周边	www.ti.com.cn/computer
数据转换器	www.ti.com.cn/dataconverters	消费电子	www.ti.com/consumer-apps
DLP® 产品	www.dlp.com	能源	www.ti.com/energy
DSP - 数字信号处理器	www.ti.com.cn/dsp	工业应用	www.ti.com.cn/industrial
时钟和计时器	www.ti.com.cn/clockandtimers	医疗电子	www.ti.com.cn/medical
接口	www.ti.com.cn/interface	安防应用	www.ti.com.cn/security
逻辑	www.ti.com.cn/logic	汽车电子	www.ti.com.cn/automotive
电源管理	www.ti.com.cn/power	视频和影像	www.ti.com.cn/video
微控制器 (MCU)	www.ti.com.cn/microcontrollers		
RFID 系统	www.ti.com.cn/rfidsys		
OMAP 机动性处理器	www.ti.com/omap		
无线连通性	www.ti.com.cn/wirelessconnectivity		
	德州仪器在线技术支持社区		www.deyisupport.com

邮寄地址: 上海市浦东新区世纪大道 1568 号, 中建大厦 32 楼 邮政编码: 200122
Copyright © 2012 德州仪器 半导体技术 (上海) 有限公司